



Technical Publication

Part Number 2300164-100

Revision 7

GE Medical Systems

Vivid™ 3 Pro/Vivid™ 3 Service Manual

Copyright© 2006 by GE Medical Systems



IMPORTANT PRECAUTIONS

WARNING

- THIS SERVICE MANUAL IS AVAILABLE IN ENGLISH ONLY.
- IF A CUSTOMER'S SERVICE PROVIDER REQUIRES A LANGUAGE OTHER THAN ENGLISH, IT IS THE CUSTOMER'S RESPONSIBILITY TO PROVIDE TRANSLATION SERVICES.
- DO NOT ATTEMPT TO SERVICE THE EQUIPMENT UNLESS THIS SERVICE MANUAL HAS BEEN CONSULTED AND IS UNDERSTOOD.
- FAILURE TO HEED THIS WARNING MAY RESULT IN INJURY TO THE SERVICE PROVIDER, OPERATOR OR PATIENT FROM ELECTRIC SHOCK, MECHANICAL OR OTHER HAZARDS.

AVERTISSEMENT

- CE MANUEL DE MAINTENANCE N'EST DISPONIBLE QU'EN ANGLAIS.
- SI LE TECHNICIEN DU CLIENT A BESOIN DE CE MANUEL DANS UNE AUTRE LANGUE QUE L'ANGLAIS, C'EST AU CLIENT QU'IL INCOMBE DE LE FAIRE TRADUIRE.
- NE PAS TENTER D'INTERVENTION SUR LES ÉQUIPEMENTS TANT QUE LE MANUEL SERVICE N'A PAS ÉTÉ CONSULTÉ ET COMPRIS.
- LE NON-RESPECT DE CET AVERTISSEMENT PEUT ENTRAÎNER CHEZ LE TECHNICIEN, L'OPÉRATEUR OU LE PATIENT DES BLESSURES DUES À DES DANGERS ÉLECTRIQUES, MÉCANIQUES OU AUTRES.

WARNUNG

- DIESES KUNDENDIENST-HANDBUCH EXISTIERT NUR IN ENGLISCHER SPRACHE.
- FALLS EIN FREMDER KUNDENDIENST EINE ANDERE SPRACHE BENÖTIGT, IST ES AUFGABE DES KUNDEN FÜR EINE ENTSPRECHENDE ÜBERSETZUNG ZU SORGEN.
- VERSUCHEN SIE NICHT, DAS GERÄT ZU REPARIEREN, BEVOR DIESES KUNDENDIENST-HANDBUCH NICHT ZU RATE GEZOGEN UND VERSTANDEN WURDE.
- WIRD DIESE WARNUNG NICHT BEACHTET, SO KANN ES ZU VERLETZUNGEN DES KUNDENDIENSTTECHNIKERS, DES BEDIENERS ODER DES PATIENTEN DURCH ELEKTRISCHE SCHLÄGE, MECHANISCHE ODER SONSTIGE GEFAHREN KOMMEN.

AVISO

- ESTE MANUAL DE SERVICIO SÓLO EXISTE EN INGLÉS.
- SI ALGÚN PROVEEDOR DE SERVICIOS AJENO A GEMS SOLICITA UN IDIOMA QUE NO SEA EL INGLÉS, ES RESPONSABILIDAD DEL CLIENTE OFRECER UN SERVICIO DE TRADUCCIÓN.
- NO SE DEBERÁ DAR SERVICIO TÉCNICO AL EQUIPO, SIN HABER CONSULTADO Y COMPRENDIDO ESTE MANUAL DE SERVICIO.
- LA NO OBSERVANCIA DEL PRESENTE AVISO PUEDE DAR LUGAR A QUE EL PROVEEDOR DE SERVICIOS, EL OPERADOR O EL PACIENTE SUFRAN LESIONES PROVOCADAS POR CAUSAS ELÉCTRICAS, MECÁNICAS O DE OTRA NATURALEZA.

ATENÇÃO

- ESTE MANUAL DE ASSISTÊNCIA TÉCNICA SÓ SE ENCONTRA DISPONÍVEL EM INGLÊS.
- SE QUALQUER OUTRO SERVIÇO DE ASSISTÊNCIA TÉCNICA, QUE NÃO A GEMS, SOLICITAR ESTES MANUAIS NOUTRO IDIOMA, É DA RESPONSABILIDADE DO CLIENTE FORNECER OS SERVIÇOS DE TRADUÇÃO.
- NÃO TENHA TENTADO REPARAR O EQUIPAMENTO SEM TER CONSULTADO E COMPREENDIDO ESTE MANUAL DE ASSISTÊNCIA TÉCNICA.
- O NÃO CUMPRIMENTO DESTA AVISO PODE POR EM PERIGO A SEGURANÇA DO TÉCNICO, OPERADOR OU PACIENTE DEVIDO A CHOQUES ELÉTRICOS, MECÂNICOS OU OUTROS.

AVVERTENZA

- IL PRESENTE MANUALE DI MANUTENZIONE È DISPONIBILE SOLTANTO IN INGLESE.
- SE UN ADDETTO ALLA MANUTENZIONE ESTERNO ALLA GEMS RICHIEDE IL MANUALE IN UNA LINGUA DIVERSA, IL CLIENTE È TENUTO A PROVVEDERE DIRETTAMENTE ALLA TRADUZIONE.
- SI PROCEDA ALLA MANUTENZIONE DELL'APPARECCHIATURA SOLO DOPO AVER CONSULTATO IL PRESENTE MANUALE ED AVERNE COMPRESO IL CONTENUTO.
- NON TENERE CONTO DELLA PRESENTE AVVERTENZA POTREBBE FAR COMPIERE OPERAZIONI DA CUI DERIVINO LESIONI ALL'ADDETTO ALLA MANUTENZIONE, ALL'UTILIZZATORE ED AL PAZIENTE PER FOLGORAZIONE ELETTRICA, PER URTI MECCANICI OD ALTRI RISCHI.

このサービスマニュアルには英語版しかありません。

GEMS以外でサービスを担当される業者が英語以外の言語を要求される場合、翻訳作業はその業者の責任で行うものとさせていただきます。

警告

このサービスマニュアルを熟読し理解せずに、装置のサービスを行わないで下さい。

この警告に従わない場合、サービスを担当される方、操作員あるいは患者さんが、感電や機械的又はその他の危険により負傷する可能性があります。

本维修手册仅存有英文本。

非 GEMS 公司的维修员要求非英文本的维修手册时，客户需自行负责翻译。

注意：

未详细阅读和完全了解本手册之前，不得进行维修。忽略本注意事项会对维修员，操作员或病人造成触电，机械伤害或其他伤害。

DAMAGE IN TRANSPORTATION

All packages should be closely examined at time of delivery. If damage is apparent write "Damage In Shipment" on ALL copies of the freight or express bill BEFORE delivery is accepted or "signed for" by a GE representative or hospital receiving agent. Whether noted or concealed, damage MUST be reported to the carrier immediately upon discovery, or in any event, within 14 days after receipt, and the contents and containers held for inspection by the carrier. A transportation company will not pay a claim for damage if an inspection is not requested within this 14 day period.

CERTIFIED ELECTRICAL CONTRACTOR STATEMENT - FOR USA ONLY

All electrical Installations that are preliminary to positioning of the equipment at the site prepared for the equipment shall be performed by licensed electrical contractors. Other connections between pieces of electrical equipment, calibrations and testing shall be performed by qualified GE Medical Systems personnel. In performing all electrical work on these products, GE will use its own specially trained field engineers. All of GE's electrical work on these products will comply with the requirements of the applicable electrical codes.

The purchaser of GE equipment shall only utilize qualified personnel (i.e., GE's field engineers, personnel of third-party service companies with equivalent training, or licensed electricians) to perform electrical servicing on the equipment.

OMISSIONS & ERRORS

If there are any omissions, errors or suggestions for improving this documentation, please contact the GE Medical Systems Global Documentation Group with specific information listing the system type, manual title, part number, revision number, page number and suggestion details. Mail the information to: Service Documentation, 4855 W. Electric Ave (EA-53), Milwaukee, WI 53219, USA.

GE Medical Systems employees should use the iTrak System to report all documentation errors or omissions.

LEGAL NOTES

The contents of this publication may not be copied or duplicated in any form, in whole or in part, without prior written permission of GE Medical Systems.

GE Medical Systems may revise this publication from time to time without written notice.

TRADEMARKS

All products and their name brands are trademarks of their respective holders.

COPYRIGHTS

All Material Copyright© 2006 by General Electric Inc. All Rights Reserved

Revision History

Revision	Date	Reason for change
0	2002	Initial Release
1	April 2002	Second Release
2	November 2002	Third Release
3	September 2003	Fourth Release
4	December 2003	New Breakthrough
5	March 2004	Hardware Modifications; Corrections
6	July 2005	Updated System Labels; added Waste Electrical and Electronic Equipment (WEEE) Disposal warning
7	February 2006	Software Upgrade

List of Effected Pages

Pages	Revision	Pages	Revision	Pages	Revision
Title Page	N/A	Chapter 2 - Pre-Installation pages 2-1 to 2-12	7	Chapter 7 - Diagnostics/ Troubleshooting pages 7-1 to 7-130	7
Important Precautions pages i to iv	7	Chapter 3 - Installation pages 3-1 to 3-78	7	Chapter 8 - Replacement Procedures pages 8-1 to 8-190	7
Legal / Rev History/LOEP pages v to vi	7	Chapter 4 - Functional Checks pages 4-1 to 4-34	7	Chapter 9 - Replacement Parts pages 9-1 to 9-38	7
Table of Contents pages vii to xxii	7	Chapter 5 - Theory pages 5-1 to 5-52	7	Chapter 10 - Periodic Maintenance pages 10-1 to 10-32	7
Chapter 1 - Introduction pages 1-1 to 1-28	7	Chapter 6 - Service Adjustments pages 6-1 to 6-18	7	Back Cover	N/A

Table of Contents

CHAPTER 1

Introduction

Overview	1 - 1
Purpose of Chapter 1	1 - 1
Purpose of Service Manual	1 - 1
Typical Users of the Basic Service Manual	1 - 2
Vivid™ 3 Models Covered in this Manual	1 - 3
System History - Hardware and Software Versions	1 - 5
Purpose of Operator Manual(s)	1 - 5
Important Conventions	1 - 6
Conventions Used in this Manual	1 - 6
Safety Considerations	1 - 8
Introduction	1 - 8
Human Safety	1 - 8
Mechanical Safety	1 - 8
Electrical Safety	1 - 9
Dangerous Procedure Warnings	1 - 10
Product Labels and Icons	1 - 11
Product Label Locations	1 - 11
Label Descriptions	1 - 13
Vivid™ 3 External Labels	1 - 15
EMC, EMI, and ESD	1 - 25
Electromagnetic Compatibility (EMC)	1 - 25
Electrostatic Discharge (ESD) Prevention	1 - 25
Standards Used	1 - 26
Lockout/Tagout Requirements (For USA Only)	1 - 26
Customer Assistance	1 - 27
Contact Information	1 - 27

CHAPTER 2

Pre-Installation

Overview	2 - 1
Purpose of Chapter 2	2 - 1
Console Requirements	2 - 2
Unit Environmental Requirements	2 - 2
Cooling Requirements	2 - 2
Lighting Requirements	2 - 2
Time and Manpower Requirements	2 - 2
Electrical Requirements	2 - 3
EMI Limitations	2 - 5
Probe Environmental Requirements	2 - 6
Facility Needs	2 - 7
Purchaser Responsibilities	2 - 7
Mandatory Site Requirements	2 - 8
Site Recommendations	2 - 8
Networking Pre-Installation Requirements	2 - 9
Connectivity Installation Worksheet	2 - 11

CHAPTER 3

Installation

Overview	3 - 1
Purpose of Chapter 3	3 - 1
Installation Reminders	3 - 2
Average Installation Time	3 - 2
Installation Warnings	3 - 2
Safety Reminders	3 - 3
Receiving and Unpacking the Equipment.	3 - 4
Unpacking the Wooden Shipping Crate	3 - 4
Unpacking the Cardboard Shipping Carton	3 - 9
Unpacking and Removing the Unit from the Cardboard Shipping Carton	3 - 9
Preparing for Installation.	3 - 13
Confirming Customer Order	3 - 13
Verifying the Shipping Crate Contents	3 - 13
Component Inspection	3 - 14
System Voltage Confirmation	3 - 19
Video Formats Confirmation	3 - 20
Ensuring Protection from EMI	3 - 21
Completing the Hardware Installation.	3 - 22
Connecting the Footswitch	3 - 22
Connecting Peripherals	3 - 23
Connecting Probes	3 - 28
Connecting the ECG	3 - 29
Connecting the Unit to a Power Source	3 - 31
Switching the System ON/OFF	3 - 33
System Configuration	3 - 35
Adjusting the Display Monitor	3 - 35
Hospital Info Tab	3 - 35
System Tab	3 - 36
Connectivity Tab	3 - 37
Archive Tab	3 - 37
Annotation Settings Tab	3 - 39
System Options Tab	3 - 41
Printers Tab	3 - 43

VCR/ECG Tab	3 - 45
Technical Support Tab	3 - 47
Technical Support History Tab	3 - 49
Connectivity Setup	3 - 50
Introduction	3 - 50
Physical Connection	3 - 50
Setting Up for Connectivity	3 - 52
Setting Up the Network Connection	3 - 55
Setting Up for Communication with a Prosolv Workstation	3 - 57
Connecting Directly to EchoPAC	3 - 63
Storing and Transporting the Unit	3 - 68
Disconnecting the Unit when Storing	3 - 68
Preparing the Unit for Transport	3 - 68
Safety Precautions for Moving the Vivid™ 3 Unit	3 - 69
Wooden Shipping Crate and Packaging Materials	3 - 69
Cardboard Shipping Carton and Packaging Materials	3 - 70
Packing the Unit into the Wooden Shipping Crate	3 - 71
Assembling the Wooden Shipping Crate	3 - 72
Packing the Unit in the Cardboard Shipping Carton	3 - 74
Assembling the Cardboard Shipping Carton	3 - 75
Completing the Installation Paperwork	3 - 76
System Installation Details	3 - 76
Product Locator Installation	3 - 76
User Manual(s)	3 - 77

CHAPTER 4

Functional Checks

Overview	4 - 1
Purpose of Chapter 4	4 - 1
General Procedures	4 - 2
Power ON/OFF and Boot-up Tests	4 - 2
Diagnostic Power Supply Test	4 - 2
Functional Check	4 - 3
Basic Controls	4 - 3
Peripherals	4 - 4
Mechanical Functions	4 - 6
Back End Processor Tests	4 - 7
Image Testing: 2D/M/CFM/Doppler	4 - 11
3S Probe Image Quality Tests	4 - 11
7S Probe Image Quality Tests	4 - 18
C358 Curved Probe Image Quality Tests	4 - 19
739L Probe Image Quality Tests	4 - 21
Probe 10S Image Quality Tests	4 - 25
2D (Pencil) Probe Image Quality Test	4 - 25
System Turnover Checklist.	4 - 26
Software Configuration Checks	4 - 26
Site Log	4 - 33

CHAPTER 5

Components and Function (Theory)

Overview	5 - 1
Purpose of Chapter 5	5 - 1
General Information	5 - 2
Block Diagrams	5 - 3
System Block Diagrams	5 - 3
Front End	5 - 7
General Information	5 - 7
Front Board Assembly (FB)	5 - 16
MUX Board	5 - 18
Beamformer Board (BF)	5 - 19
Radio Frequency Interface (RFI) Board	5 - 20
Front End Controller Board (FEC) (RFT)	5 - 23
RF and Tissue Processor Board (RFT)	5 - 24
Image Port Board (IMP)	5 - 25
Back Plane Board (Motherboard)	5 - 25
Back End Processor	5 - 26
Introduction	5 - 26
Central Processing Unit (CPU)	5 - 31
Keyboard Controller	5 - 34
Multifunction I/O Controller	5 - 35
Frame Grabber (RFI systems only)	5 - 35
PC2IP	5 - 35
Plug and Scan Card and Battery	5 - 35
Network Onboard	5 - 35
SCSI Card	5 - 35
Floppy Drive	5 - 36
Hard Disk	5 - 36
Magneto-Optical Drive (MOD)	5 - 37
CD Read Write (CDRW)	5 - 37
ECG Module	5 - 37
Modem	5 - 38
PC-VIC Assembly	5 - 39
External Peripherals	5 - 41

Introduction	5 - 41
Vivid™ 3 Power Distribution	5 - 42
Electrical Power	5 - 42
AC System	5 - 43
AC Distribution Box	5 - 45
Front End DC Power Distribution	5 - 47
Front End Cooling System	5 - 49
General Description	5 - 49
Location in the Unit	5 - 49
Common Service Platform	5 - 50
Introduction	5 - 50
<i>iLinq</i> Interactive Platform Features	5 - 50
Global Service User Interface (GSUI)	5 - 51

CHAPTER 6

Service Adjustments

Overview	6 - 1
Purpose of Chapter 6	6 - 1
Input AC Voltage Configuration	6 - 2
Secondary Voltage Configuration	6 - 2
AC Input Cord	6 - 2
Front End Voltages and Signal Indicators	6 - 3
RFI LEDs	6 - 5
Image Port (IMP) LEDs	6 - 5
Front End Controller (FEC) LEDs	6 - 6
RF and Tissue Processor (RFT)	6 - 6
Beamformer (BF)	6 - 6
Channels Multiplexer (MUX)	6 - 7
Front Board Assembly (FB)	6 - 7
Back End Power Supply Voltages	6 - 8
VIC Video Signal Setting	6 - 8
Video Format Confirmation	6 - 8
Monitor Operation	6 - 9
Vivid™ 3 Samsung 15" and 17" Monitor Operation	6 - 9
Image Quality Calibration	6 - 12
Image Quality Calibration for the Vivid™ 3 15" and 17" Samsung Monitors	6 - 12
Calibration	6 - 14
Accessing the Calibration Options	6 - 14
Monitor Calibration	6 - 16
Beamformer Calibration	6 - 17
Video Grabbing Calibration	6 - 17

CHAPTER 7

Diagnostics/Troubleshooting

Overview	7 - 1
Purpose of Chapter	7 - 1
Diagnostics	7 - 2
Diagnostic Tools	7 - 2
Diagnostic Procedure Summary	7 - 2
Accessing the Diagnostic Menu	7 - 3
Performing Front End (FE) Diagnostics	7 - 5
Accessing the Front End Diagnostic Options	7 - 6
Radio Frequency Interface (RFI) Diagnostic Tests (for RFI Configuration)	7 - 11
Image Port (IMP) Diagnostic Tests (for RFT Configuration)	7 - 13
VME Bus (VME) Diagnostic Tests (for RFT Configuration)	7 - 15
RFT Diagnostic Tests (for RFT Configuration)	7 - 17
Front End Controller (FEC) Diagnostic Tests (for RFT Configuration)	7 - 19
Beamformer (BF) Diagnostic Tests	7 - 21
Front Board Assembly (FB) Diagnostic Tests	7 - 25
MUX Diagnostic Tests	7 - 47
H/W Report	7 - 66
Current Report	7 - 67
Performing Back End Diagnostics on the System	7 - 68
Accessing the Back End Diagnostic Options	7 - 68
Audio (Doppler Sound Driver) Diagnostic Test	7 - 70
ECG/Phono Diagnostic Test	7 - 71
External Keyboard Diagnostic Test	7 - 73
Keyboard Diagnostic Test	7 - 76
Media Driver Diagnostic Test	7 - 77
Computer Diagnostic Test	7 - 79
UPS Test	7 - 82
Checking the Network Adaptors from Windows Device Manager	7 - 83
Common Service Interface	7 - 84
iLinq Interactive Platform Features	7 - 84
Global Service User Interface	7 - 84
Error Logs Page	7 - 88
Diagnostics Page	7 - 96
Image Quality Page	7 - 109

Calibration Page	7 - 109
Configuration Page	7 - 110
Utilities Page	7 - 111
Replacement Page	7 - 125
PM Page	7 - 125
Automatic Error Log	7 - 126
Adding Comments to the Daily Logger Report	7 - 126
Saving the Logger Report	7 - 127
Sending the Logger Report	7 - 127

CHAPTER 8

Replacement Procedures

Overview	8 - 1
Purpose of Chapter 8	8 - 1
Cover Replacement Procedures	8 - 2
Overview of Covers	8 - 2
Side Covers Replacement Procedures	8 - 4
Front Cover and Air Filter Replacement Procedures	8 - 5
Rear Cover Replacement Procedures	8 - 7
Connector Panels Cover Replacement Procedures	8 - 8
Top Cover (Lower Section) Replacement Procedures	8 - 9
Gas Spring Cover Replacement Procedure	8 - 13
Bottom Keyboard Cover Replacement Procedure	8 - 14
Speaker Cover Replacement Procedure	8 - 16
Control Console Bottom Cover (Upper Section) Replacement Procedure	8 - 17
Control Console Top Cover Replacement Procedure (Upper Section)	8 - 20
Right and Left Probe Holders Replacement Procedure	8 - 23
Front Handle Replacement Procedure	8 - 24
Rear Handle Replacement Procedure	8 - 25
Control Console Components Replacement	8 - 27
Vivid™ 3 Monitor 15" Replacement Procedure (Samsung; P/N 2336022-2)	8 - 27
Vivid™ 3 17" Monitor Replacement - Procedure 1	8 - 30
Vivid™ 3 17" Monitor Replacement - Procedure 2	8 - 34
Keyboard Replacement Procedure	8 - 37
Keypad Replacement Procedure	8 - 38
Keypads (External Keyboard) Replacement Procedure	8 - 39
Rotary Knob (External Keyboard) Replacement Procedure	8 - 40
Trackball Replacement Procedure	8 - 42
Speaker Replacement Procedure	8 - 43
Front End Parts Replacement	8 - 44
Front End Boards Replacement Procedure	8 - 44
TR4 Boards Replacement Procedure	8 - 46
DC Power Supply Replacement Procedure	8 - 48
TX Power Supply Replacement Procedure	8 - 48
Front End Crate Replacement Procedure	8 - 50
Fan Replacement Procedure	8 - 52

Back End Parts Replacement	8 - 54
Preparation	8 - 54
Back End Processor Replacement Procedure	8 - 58
BEP1 Cover Replacement Procedure	8 - 64
BEP2 Cover and Octopus Card Holder Replacement Procedure	8 - 66
Plug & Scan Board Replacement Procedure	8 - 69
Plug & Scan Battery Replacement Procedure	8 - 70
VGA AGP Board Replacement Procedure	8 - 72
SCSI Board Replacement Procedure	8 - 73
PC2IP Board Replacement Procedure	8 - 75
Frame Grabber Board Replacement Procedure	8 - 76
Keyboard Control Board Replacement Procedure	8 - 77
CDRW Drive Replacement Procedure	8 - 78
MO Drive Replacement Procedure	8 - 80
ECG Module Replacement Procedure	8 - 82
PC-VIC Replacement Procedure	8 - 87
BEP2 Power Supply Replacement Procedure	8 - 90
Hard Disk Replacement Procedure	8 - 96
Lower Section Components Replacement.	8 - 99
AC Distribution Box Replacement Procedure	8 - 99
AC Input Box Replacement Procedure	8 - 101
Keyboard or Monitor Cable Replacement Procedure	8 - 102
AC, BEP or FE Cable Replacement Procedure	8 - 103
Gas Spring Cable Replacement Procedure	8 - 104
Up/Down Handle Replacement Procedure	8 - 106
Gas Spring Replacement Procedure	8 - 111
Front Wheel Replacement Procedure	8 - 114
Rear Wheel Replacement Procedure	8 - 119
Software Loading	8 - 121
Software Installation/Upgrade Procedure	8 - 121
Peripherals.	8 - 123
B/W Video Printer Replacement Procedure	8 - 123
Mitsubishi VCR Replacement Procedure	8 - 128
Sony VCR Replacement Procedure	8 - 136
JVC VCR Replacement Procedure	8 - 141
Panasonic VCR Replacement Procedure	8 - 151
Sony UP 2950 MD & 2800P Color Video Printer Replacement Procedure	8 - 156
Sony UP-21MD Color Video Printer Replacement Procedure	8 - 167

HP 6540/3 USB Deskjet Color Printer Replacement Procedure for Vivid™ 3 BT03 Systems	8 - 175
--	---------

CHAPTER 9

Renewal Parts

Overview	9 - 1
Purpose of Chapter 9	9 - 1
List of Abbreviations	9 - 2
Renewal Parts Lists and Diagrams	9 - 3
Mechanical Hardware Parts	9 - 3
AC System Parts	9 - 9
Front End Parts	9 - 11
Back End Parts	9 - 15
Cables	9 - 21
Software	9 - 33
Probes	9 - 34
Peripherals	9 - 35
Cabling Block Diagrams	9 - 36

CHAPTER 10

Periodic Maintenance

Overview	10 - 1
Purpose of Chapter 10	10 - 1
Warnings	10 - 1
Why Perform Periodic Maintenance Procedures?	10 - 2
Keeping Records	10 - 2
Quality Assurance	10 - 2
Periodic Maintenance Schedule	10 - 3
How Often Should PM Procedures be Performed?	10 - 3
Tools Required	10 - 6
Special Tools, Supplies and Equipment	10 - 6
System Periodic Maintenance	10 - 7
Preliminary Checks	10 - 7
Functional Checks	10 - 8
Input Power Checks	10 - 9
Cleaning	10 - 10
Physical Inspection	10 - 12
Diagnostic Checks (Optional)	10 - 13
Probe Maintenance	10 - 14
Probe Checks	10 - 14
Probe Handling	10 - 14
Basic Probe Care	10 - 15
Probe Cleaning and Disinfecting	10 - 15
Returning and Shipping of Defective Probes	10 - 16
Electrical Safety Tests	10 - 17
Safety Test Overview	10 - 17
GEMS Current Leakage Limits	10 - 18
Outlet Test Wiring Arrangement - USA & Canada	10 - 19
Grounding Continuity	10 - 19
Chassis Current Leakage Test	10 - 21
Isolated Patient Lead (Source) Leakage – Lead-to-Ground	10 - 23
Isolated Patient Lead (Source) Leakage – Lead-to-Lead	10 - 24
Isolated Patient Lead (Sink) Leakage - Isolation Test	10 - 24

Probe Current Leakage Test	10 - 26
Excessive Current Leakage	10 - 29
Possible Causes of Excessive Current Leakage	10 - 29
PM and Safety Inspection Certificates	10 - 30

Chapter 1

Introduction

Section 1-1 Overview

1-1-1 Purpose of Chapter 1

This chapter describes important issues related to safely servicing the Vivid™ 3 scanner. The service provider must read and understand all the information presented here before installing or servicing a unit.

Table 1-1 Contents in Chapter 1

Section	Description	Page Number
1-1	Overview	1-1
1-2	Important Conventions	1-6
1-4	Product Labels and Icons	1-11
1-3	Safety Considerations	1-8
1-5	EMC, EMI, and ESD	1-25
1-6	Customer Assistance	1-27

1-1-2 Purpose of Service Manual

This manual provides installation and service information for the Vivid™ 3 ultrasound unit, and contains the following chapters:

- *Chapter 1 - Introduction:*
Contains a content summary and warnings.
- *Chapter 2 - Pre-Installation*
Contains pre-installation requirements for the Vivid™ 3 ultrasound unit.
- *Chapter 3 - Installation*
Contains installation procedures and an installation checklist.
- *Chapter 4 - Functional Checks*
Contains functional checks that are recommended as part of the installation procedure, or as required during servicing and periodic maintenance.
- *Chapter 5 - Components and Function (Theory)*
Contains block diagrams and functional explanations of the electronic circuits.
- *Chapter 6 - Service Adjustments*
Contains instructions for performing service adjustments to the Vivid™ 3 ultrasound unit.
- *Chapter 7 - Diagnostics/Troubleshooting*
Provides instructions for setting up and running diagnostic, troubleshooting and other related routines for the Vivid™ 3 ultrasound unit.

- [Chapter 8 - Replacement Procedures](#)
Provides disassembly and reassembly procedures for all Field Replaceable Units (FRUs).
- [Chapter 9 - Renewal Parts](#)
Contains a complete list of field replaceable parts for the Vivid™ 3 ultrasound unit.
- [Chapter 10 - Periodic Maintenance](#)
Provides periodic maintenance procedures for the Vivid™ 3 ultrasound unit.

1-1-3 Typical Users of the Basic Service Manual

This manual is intended for the following categories of users:

- GE service personnel (installation, maintenance, etc.).
- Hospital service personnel.
- Contractors (some parts of [Chapter 2 - Pre-Installation](#)).

1-1-4 Vivid™ 3 Models Covered in this Manual

The Vivid™ 3 models documented in this manual are shown in [Table 1-2](#) and [Table 1-3](#) below.

NOTE: *The difference between the two types of Vivid™ 3 BTO3 models are as follows:
 On RFI models (supported by software version 3.2, and above), Image Port, RFT, and FEC functionality are all incorporated into one board - the RFI board.
 For RFT models (supported by software versions below 3.2), the Image Port, RFT, and FEC boards are all separate components.*

Table 1-2 Vivid™ 3 - BT03 - RFI Models

Model	Cat No.	Description	Comments
BASE Vivid 3 Console			
Vivid 3 BT03 console, 220-240V AC, RFI	H45011GD	An advanced version of the newer generation of the Vivid™ 3 BT03 Ultrasound Scanning System. Enables a larger variety of probes and larger application use.	The BT03 is backward compatible to its parallel product, the BT02 Pro and Expert and its predecessor BT01 Pro and Expert. Contact your local distributor for more information about upgrades and backward compatibility. BT00 hardware cannot be upgraded to this level.
Vivid 3 BT03 console, 100V AC, RFI	H45011GE		
Vivid 3 BT03 console, 110-120V AC, RFI	H45011GF		
Vivid 3 BT03 console, 220-230V AC / NTSC, RFI	H45011GG		
Vivid 3 BT03 console, NTRL, RFI	H45521JB		
PRO Console			
Vivid 3 BT03 PRO console, 220-240V AC, RFI	H45011G	New generation of the Vivid™ 3 Ultrasound Scanning System, continuation of the product line of Vivid™ 3 BT01 & BT02. For global universal use.	The Pro is backward compatible to its predecessor, the BT01 & BT02. Contact your local distributor for more information about upgrades and backward compatibility. BT00 hardware cannot be upgraded to this level
Vivid 3 BT03 PRO console, 100V AC, RFI	H45011GA		
Vivid 3 BT03 PRO console, 110-120V AC, RFI	H45011GB		
Vivid 3 BT03 PRO console, 220V-230V AC / NTSC, RFI	H45011GC		
Vivid 3 BT03 PRO console, NTRL, RFI	H45521JA		

Table 1-3 Vivid™ 3 - BT03 - RFT Models

Model	Cat No.	Description	Comments
BASE Vivid 3 Console			
Vivid 3 BT03 console, 220-240V AC	H45011ES	An advanced version of the newer generation of the Vivid™ 3 BT03 Ultrasound Scanning System. Enables a larger variety of probes and larger application use.	The BT03 is backward compatible to its parallel product, the BT02 Pro and Expert and its predecessor BT01 Pro and Expert. Contact your local distributor for more information about upgrades and backward compatibility. BT00 hardware cannot be upgraded to this level.
Vivid 3 BT03 console, 100V AC	H45011ET		
Vivid 3 BT03 console, 110-120V AC	H45011EU		
Vivid 3 BT03 console, 220-230V AC / NTSC	H45011EV		
Vivid 3 BT03 console, NTRL	H45521EW		
PRO Console			
Vivid 3 BT03 PRO console, 220-240V AC	H45011FD	New generation of the Vivid™ 3 Ultrasound Scanning System, continuation of the product line of Vivid™ 3 BT01 & BT02. For global universal use.	The Pro is backward compatible to its predecessor, the BT01 & BT02. Contact your local distributor for more information about upgrades and backward compatibility. BT00 hardware cannot be upgraded to this level
Vivid 3 BT03 PRO console, 100V AC	H45011FE		
Vivid 3 BT03 PRO console, 110-120V AC	H45011FF		
Vivid 3 BT03 PRO console, 220V-230V AC / NTSC	H45011FG		
Vivid 3 BT03 PRO console, NTRL	H45521FH		

NOTE: Vivid™ 3 systems with Serial No 5000 and above, have the RFI system hardware configuration. All systems with a serial number prior to this (i.e. 4999 and below) are configured with RFT hardware.

1-1-5 System History - Hardware and Software Versions

The newest generation of the Vivid™ 3 (BT03) ultrasound unit is based on its predecessor, the Vivid™ 3 (BT01 and BT02) ultrasound unit, and is therefore backward compatible. The Vivid™ 3 ultrasound unit enables advanced features in a compact and user friendly tool.

Note: Vivid™ 3 (BT00) cannot be upgraded to the Vivid™ 3 Pro 03 as was the case for Pro 02.

The Vivid™ 3 Pro and Vivid™ 3 are the same generation of products, but differ in their functionality, enabling customers to receive some of the advanced Vivid™ 3 features. With minor software and hardware modifications, the Vivid™ 3 Pro can be upgraded to the Vivid™ 3 - refer to [Table 1-4](#) .

Table 1-4 Vivid™ 3 Upgrade Options Available

Part No.	Upgrade	Comments
H45011BA	BT00 to BT00 Pro upgrade	
H45011BP	BT00 to BT00 Pro upgrade for P509 probe	
H45011BC	Platform upgrade from Vivid™ 3 BT01 "Pro" to "Expert"	
H45011DL	BT00 to Pro-02 upgrade	
H45011DM	BT00 Pro to Pro-02 upgrade	
H45011DR	BT01 Pro to Pro-02 upgrade	
H45011DS	BT01 Expert to Expert -02 upgrade	
H45011FB	BT01/BT02 Pro to BT03 Upgrade	New
H45011FC	BT01/BT02 Expert to BT03 Upgrade	New
H45011BN	3rd Probe Connector for Vivid 3 system field upgrade	New
H45011MK	17 " Monitor field upgrade	New

1-1-6 Purpose of Operator Manual(s)

The Operator Manual(s) should be fully read and understood before operating the Vivid™ 3 system, and also kept near the unit for quick reference.

Section 1-2 Important Conventions

1-2-1 Conventions Used in this Manual

1-2-1-1 Model Designations

This manual covers the Vivid™ 3 ultrasound units listed in [Table 1-2 on page 1-3](#) and [Table 1-3 on page 1-4](#).

1-2-1-2 Icons

Pictures, or icons, are used wherever they will reinforce the printed message. The icons, labels and conventions used on the product and in the service information are described in this chapter.

1-2-1-3 Safety Precaution Messages

Various levels of safety precautions are found on the equipment and throughout this service manual. Different levels of severity are identified by one of the following icons which precede precautionary statements in the text.



DANGER: Indicates the presence of a hazard that will cause severe personal injury or death if the instructions are ignored.



WARNING: Indicates the presence of a hazard that can cause severe personal injury and property damage if the instructions are ignored.



CAUTION: Indicates the presence of a hazard that can cause property damage but has absolutely no personal injury risk.







Note: Notes are used to provide important information about an item or a procedure. Be sure to read the notes as the information they contain can often save you time or effort.

1-2-1-4 Standard Hazard Icons

Important information will always be preceded by the exclamation point contained within a triangle, as seen throughout this chapter. In addition to text, several different graphical icons (symbols) may be used to make you aware of specific types of hazards that could cause harm.

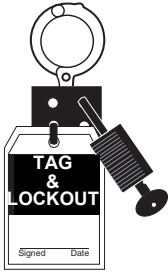



Table 1-5 Standard Hazard Icons

ELECTRICAL	MECHANICAL	RADIATION
		
LASER	HEAT	PINCH
		

Other hazard icons make you aware of specific procedures that should be followed.

Table 1-6 Standard Icons Indicating a Special Procedure Be Used

AVOID STATIC ELECTRICITY	TAG AND LOCK OUT	WEAR EYE PROTECTION
		

Section 1-3 Safety Considerations

1-3-1 Introduction

The following safety precautions must be observed during all phases of operation, service and repair of this equipment. Failure to comply with these precautions or with specific warnings elsewhere in this manual, violates safety standards of design, manufacture and intended use of the equipment.

1-3-2 Human Safety

Operating personnel must not remove the system covers.
Servicing should be performed by authorized personnel only.
Only personnel who have participated in Vivid™ 3 Training are authorized to service the equipment.

1-3-3 Mechanical Safety



DANGER: WHEN THE UNIT IS RAISED FOR A REPAIR OR MOVED ALONG ANY INCLINE, USE EXTREME CAUTION SINCE IT MAY BECOME UNSTABLE AND TIP OVER.



DANGER: ULTRASOUND PROBES ARE HIGHLY SENSITIVE MEDICAL INSTRUMENTS THAT CAN EASILY BE DAMAGED BY IMPROPER HANDLING. USE CARE WHEN HANDLING AND PROTECT FROM DAMAGE WHEN NOT IN USE. DO NOT USE A DAMAGED OR DEFECTIVE PROBE. FAILURE TO FOLLOW THESE PRECAUTIONS CAN RESULT IN SERIOUS INJURY AND EQUIPMENT DAMAGE.



DANGER: NEVER USE A PROBE THAT HAS BEEN SUBJECTED TO MECHANICAL SHOCK OR IMPACT. EVEN IF THE PROBE APPEARS TO BE UNBROKEN, IT MAY IN FACT BE DAMAGED.



CAUTION: Always lower and center the Operator I/O Panel before moving the scanner.



CAUTION: The Vivid™ 3 weighs 160 kg (353 lbs.) or more, depending on installed peripherals, when ready for use. Care must be used when moving it or replacing its parts. Failure to follow the precautions listed could result in injury, uncontrolled motion and costly damage.

ALWAYS:

Be sure the pathway is clear.

Use slow, careful motions.

Use two people when moving the system on inclines or lifting more than 16 kg (35 lbs.):



WARNING: Always lock the control console in its parking (locked) position after moving the system. Failure to do so could result in personal injury or equipment damage.



WARNING: Equipment damage could result if special care is not taken when transporting the system in a vehicle.

ALWAYS:

- Secure the system in an upright position and lock the wheels (brake).
- DO NOT use the control console as an anchor point.
- Place the probes in their carrying case.
- Eject any disks from the MOD (if installed).
- Ensure that the system is well prepared and packed in its original packaging before transporting. Special care must be taken to correctly position the packing material supporting the monitor. For further information, refer to *Chapter 3 - Installation*.



CAUTION: Keep the heat venting holes on the monitor unobstructed to avoid overheating of the monitor.

1-3-4 Electrical Safety

To minimize shock hazard, the equipment chassis must be connected to an electrical Ground. The system is equipped with a three-conductor AC power cable. This must be plugged into an approved electrical outlet with safety grounding.

The power outlet used for this equipment should not be shared with other types of equipment. Both the system power cable and the power connector must meet international electrical standards.

1-3-4-1 Probes

All the probes for the Vivid™ 3 ultrasound unit are designed and manufactured to provide trouble-free, reliable service. To ensure this, correct handling of probes is important and the following points should be noted:

- Do not drop a probe or strike it against a hard surface, as this may damage the transducer elements, acoustic lens, or housing.
- Do not use a cracked or damaged probe. In this event, call your field service representative immediately to obtain a replacement.
- Avoid pulling, pinching or kinking the probe cable, since a damaged cable may compromise the electrical safety of the probe.
- To avoid the risk of a probe accidentally falling, do not allow the probe cables to become entangled, or to be caught in the machine's wheels.

NOTE: For detailed information on handling endocavity probes, refer to the appropriate supplementary instructions for each probe. In addition, refer to the Vivid™ 3 Pro/Vivid™ 3 Expert User Manual for detailed probe handling instructions.

1-3-5 Dangerous Procedure Warnings

Warnings, such as the examples below, precede potentially dangerous procedures throughout this manual. Instructions contained in the warnings must be followed.



DANGEROUS VOLTAGES, CAPABLE OF CAUSING DEATH, ARE PRESENT IN THIS EQUIPMENT. USE EXTREME CAUTION WHEN HANDLING, TESTING AND ADJUSTING.



EXPLOSION WARNING

DO NOT OPERATE THE EQUIPMENT IN AN EXPLOSIVE ATMOSPHERE.

OPERATION OF ANY ELECTRICAL EQUIPMENT IN SUCH AN ENVIRONMENT CONSTITUTES A DEFINITE SAFETY HAZARD.



DO NOT SUBSTITUTE PARTS OR MODIFY EQUIPMENT

BECAUSE OF THE DANGER OF INTRODUCING ADDITIONAL HAZARDS, DO NOT INSTALL SUBSTITUTE PARTS OR PERFORM ANY UNAUTHORIZED MODIFICATION OF THE EQUIPMENT.

Section 1-4 Product Labels and Icons

The Vivid™ 3 ultrasound unit comes equipped with product labels and icons. These labels and icons represent pertinent information regarding the operation of the ultrasound unit.

1-4-1 Product Label Locations

The following two diagrams indicate the location of some of the labels and icons found on the Vivid™ 3 ultrasound units. All the labels and icons are described in [Table 1-7 on page 1-13](#).



Figure 1-1 Product Label and Icon Locations (Front)

- 1 Product Logo
- 2 Equipment Type CF
- 3 Parking Label on Brake Pedal
- 4 Class II Equipment
- 5 Swivel Brake Label on Brake Pedal



Figure 1-2 Product Label and Icon Locations (Rear)

- 1 Main Label
- 2 AC Voltage Rating Label
- 3 GND Label

1-4-2 Label Descriptions

The following table shows the labels and symbols that may be found on the Vivid™ 3 ultrasound unit, and provides a description of each label's purpose and location.

Table 1-7 Product Icons









Label Name	Description	Location
Product Logo	Identifies Vivid™ 3 models.	Front of the unit.
Identification and Rating Plate	Manufacturer's name and address. Date of Manufacture. Model and Serial numbers. Electrical ratings.	Rear of the unit, near the power inlet.
	Class I Equipment, in which protection against electric shock does not rely on basic insulation only, but which includes an additional safety precaution in that means are provided for the connection of the equipment to the protective earth conductor in the fixed wiring of the installation - in such a way that accessible metal parts cannot become <i>live</i> in the event of a failure of the basic insulation.	Rear of the unit and probe connectors.
Device Listing/Certification Labels	Laboratory logos or labels that denote conformity with industry safety standards, such as UL or IEC.	Rear of the unit.
	CE certification mark.	Rear of the unit, on the main label.
	Equipment Type BF (man in the box symbol) IEC 878-02-03 indicates B Type equipment having even more electrical isolation than standard Type B equipment because it is intended for intimate patient contact.	Probe connectors PCG connector or Rear of Console
	Equipment Type CF IEC 878-02-05 indicates equipment having a floating applied part that provides a degree of protection suitable for direct cardiac contact.	Front of the unit, ECG connector and surgical probes.
CAUTION - This machine weighs...Special care must be used to avoid... 	This precaution is intended to prevent injury that may be caused by the weight of the machine if one person attempts to move it considerable distances or on an incline.	Used in the Service and User Manual which should be adjacent to equipment at all times for quick reference.

Table 1-7 Product Icons (Continued)

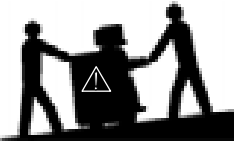
Label Name	Description	Location
"DANGER - Risk of explosion used in..."	The system is not designed for use with flammable anesthetic gases.	Indicated in the Service Manual.
	"CAUTION" The equilateral triangle is usually used in combination with other symbols to advise or warn the user.	Rear of the unit.
	"ATTENTION - Consult accompanying documents" is intended to alert the user to refer to the User Manual or other instructions when complete information cannot be provided on the label.	Rear of the unit.
	"CAUTION - Dangerous voltage" (the lightning flash with arrowhead in equilateral triangle) is used to indicate electric shock hazards.	Rear of the unit.
	"Protective Earth" Indicates the protective earth (grounding) terminal.	Rear of the unit.
	"Equipotentiality" Indicates the terminal to be used for connecting equipotential conductors when interconnecting (grounding) with other equipment.	Peripherals
	<p>Waste Electrical and Electronic Equipment (WEEE) Disposal</p> <p>This symbol indicates that the waste of electrical and electronic equipment must not be disposed as unsorted municipal waste and must be collected separately.</p> <p>Please contact an authorized representative of the manufacturer for information concerning the decommissioning of your equipment.</p>	Rear of the unit.

1-4-3 Vivid™ 3 External Labels

In addition to the labels described in the previous section, additional labels may be found on the Vivid™ 3 ultrasound unit, as described in the following sections:

- *Main Label* section, on page 1-15.
- *Rating Labels* section, on page 1-23.
- *GND Label* section, on page 1-24.
- *Parking Label* section, on page 1-24.
- *Swivel Brake Label* section, on page 1-24.

1-4-3-1 Main Label

The main label may be printed in any of the following languages: *English, German, French, Spanish, Portuguese, Italian, Chinese, Danish, Dutch, Finnish, Greek, Japanese, Norwegian, Russian, or Swedish*, as shown in the examples below. Each main label includes a serial number, a voltage rating, caution warnings, danger warnings and classifications (UL, CE0344 and so on.)

- **English:** Used for all countries except those in which German, French, Spanish, Portuguese or Italian are spoken.

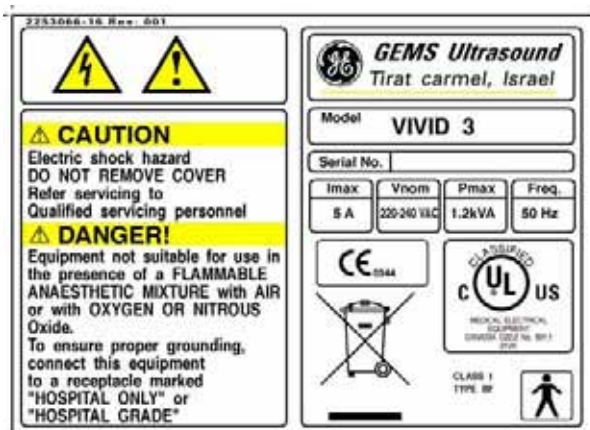

Figure 1-3 Main Label (English) 220 -240V

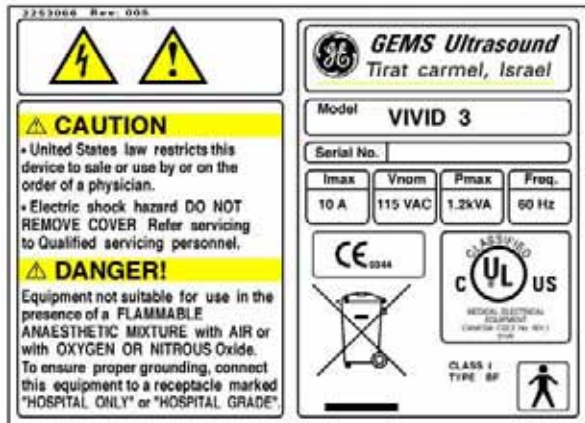

Figure 1-4 Main Label (English) USA

- **German:** Used in all German language countries.

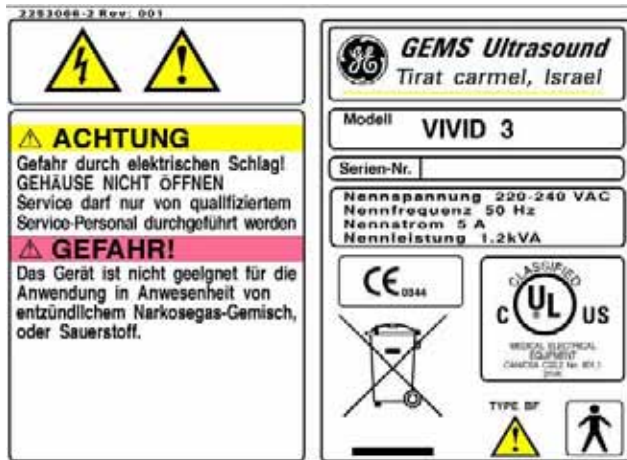

Figure 1-5 Main Label (German)

- **French:** Used in all French language countries.

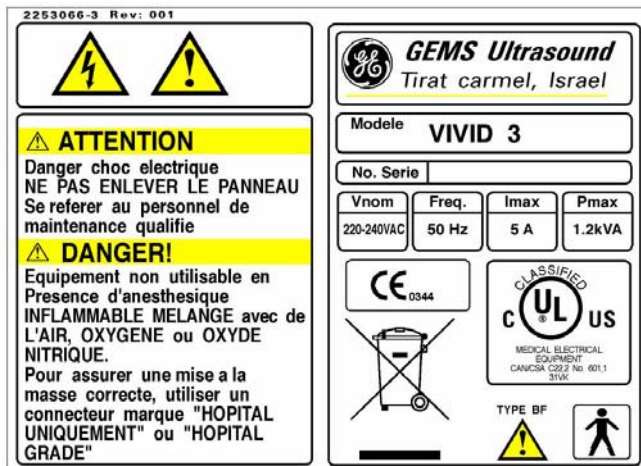

Figure 1-6 Main Label (French)

- **Spanish:** Used in all Spanish language countries.



Figure 1-7 Main Label (Spanish)

- **Portuguese:** Used in all Portuguese language countries.



Figure 1-8 Main Label (Portuguese)



Figure 1-9 Main Label (Portuguese) 220 - 240V

- **Italian:** Used in all Italian language countries.

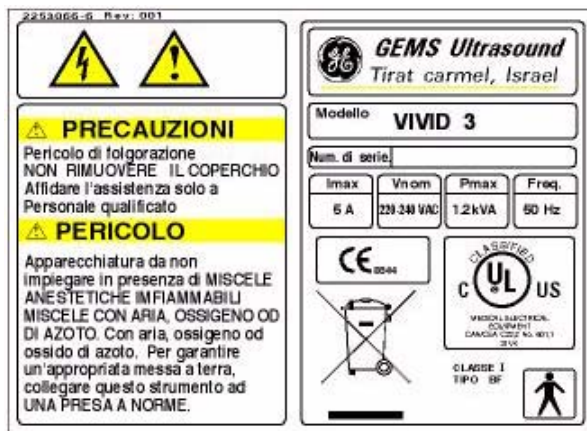

Figure 1-10 Main Label (Italian)

- **Chinese:** Used in all Chinese language countries.

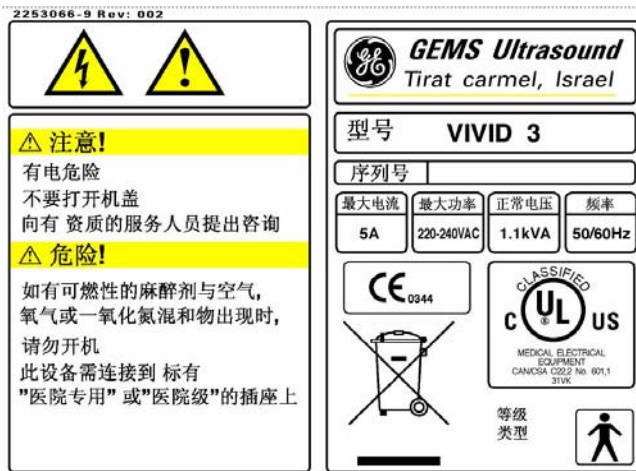

Figure 1-11 Main Label (Chinese)

- **Danish:** Used in all Danish language countries.

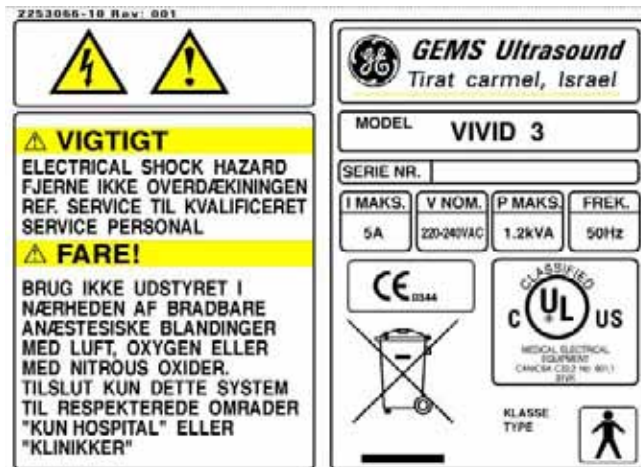

Figure 1-12 Main Label (Danish)

- **Dutch:** Used in all Dutch language countries.

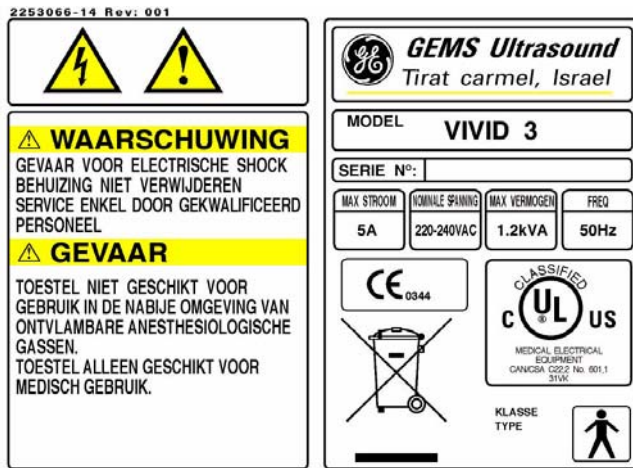

Figure 1-13 Main Label (Dutch)

- **Finnish:** Used in all Finnish language countries.

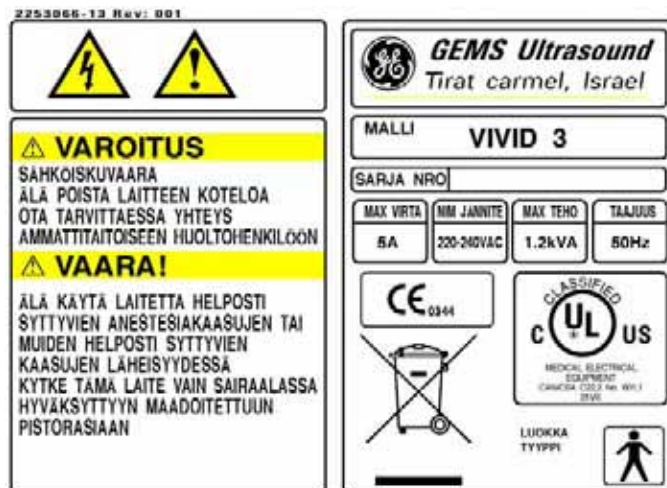

Figure 1-14 Main Label (Finnish)

- **Greek:** Used in all Greek language countries.

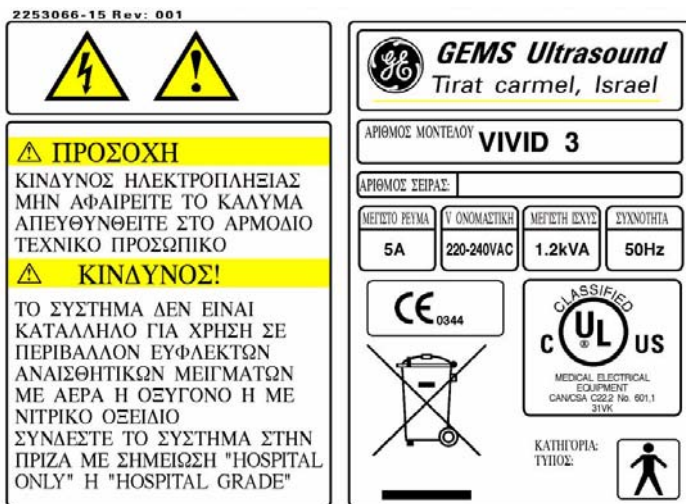

Figure 1-15 Main Label (Greek)

- **Japanese:** Used in all Japanese language countries.

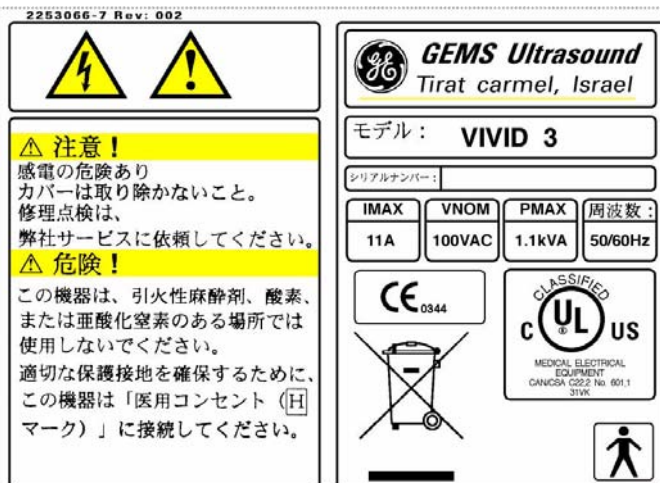

Figure 1-16 Main Label (Japanese)

- **Norwegian:** Used in all Norwegian language countries.

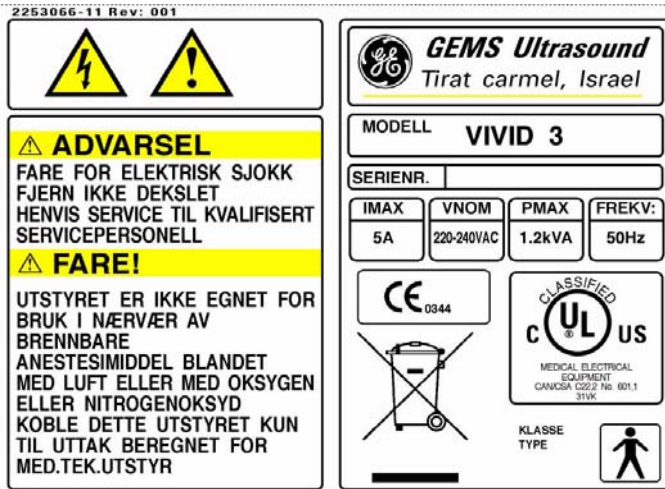

Figure 1-17 Main Label (Norwegian)

- **Russian:** Used in all Russian language countries.

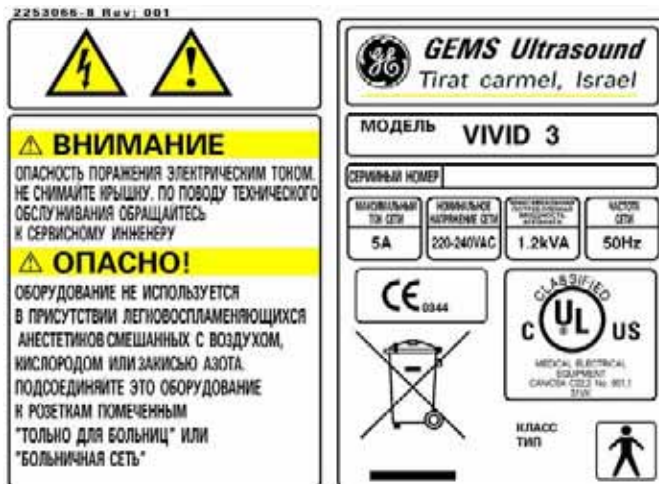

Figure 1-18 Main Label (Russian)

- **Swedish:** Used in all Swedish language countries.

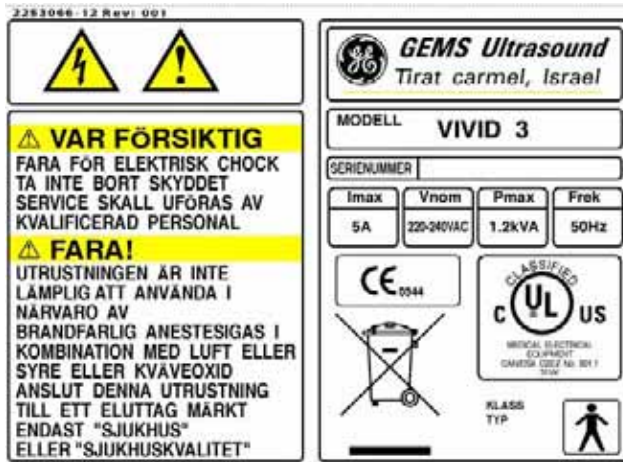

Figure 1-19 Main Label (Swedish)

1-4-3-2 Rating Labels

Indicates the ultrasound unit's factory preset input AC voltage as follows:

- AC 100V
- AC 120V
- AC 220-240V

One of the rating labels shown below is located on the rear of the ultrasound unit, as shown in [Figure 1-2](#) on page 1-12.

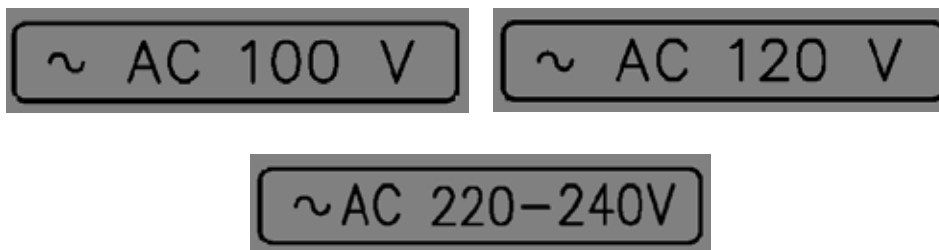

Figure 1-20 Rating Labels

1-4-3-3 GND Label

Indicates the protective earth (grounding) terminal. The GND label shown below is located at the rear of the unit, as shown in [Figure 1-2](#) on page 1-12.



Figure 1-21 GND Label

1-4-3-4 Parking Label

Indicates the locked pedal position which locks the front castors and prevents the ultrasound unit from moving. The parking label, shown below, is located on the brake pedal at the front of the unit, as shown in [Figure 1-1](#) on page 1-11.



Figure 1-22 Parking Label

1-4-3-5 Swivel Brake Label

Indicates the locked swivel position which prevents the front castors from swiveling. The swivel brake label, shown below, is located on the brake pedal at the front of the unit, as shown in [Figure 1-1](#) on page 1-11.



Figure 1-23 Swivel Break Label

Section 1-5 EMC, EMI, and ESD

1-5-1 Electromagnetic Compatibility (EMC)

Electromagnetic compatibility describes a level of performance of a device within its electromagnetic environment. This environment consists of the device itself and its surroundings, including other equipment, power sources and persons with which the device must interface. Inadequate compatibility results when a susceptible device fails to perform as intended due to interference from its environment, or when the device produces unacceptable levels of emission. This interference is often referred to as radio-frequency or electromagnetic interference (RFI/EMI) and can be radiated through space or conducted over interconnecting power or signal cables. In addition to electromagnetic energy, EMC also includes possible effects from electrical fields, magnetic fields, electrostatic discharge and disturbances in the electrical power supply.

1-5-2 Electrostatic Discharge (ESD) Prevention



CAUTION: DO NOT TOUCH ANY BOARDS WITH INTEGRATED CIRCUITS PRIOR TO TAKING THE NECESSARY ESD PRECAUTIONS:



1.ALWAYS CONNECT YOURSELF, VIA AN ARM-WRIST STRAP, TO THE ADVISED ESD CONNECTION POINT LOCATED ON THE REAR OF THE SCANNER (TO THE RIGHT OF THE POWER CONNECTOR).

2.FOLLOW GENERAL GUIDELINES FOR HANDLING OF ELECTROSTATIC SENSITIVE EQUIPMENT.

1-5-3 Standards Used

To fulfill the requirements of relevant EC directives and/or European Harmonized/International standards, the following documents/standards have been used:

Table 1-8 Standards Used

Standard/Directive	Scope
89/336/EEC	EMC Directive.
93/42/EEC	Medical Device Directive.
IEC 801-2	Electrostatic Discharge.
IEC 801-3	Radiated Electromagnetic Field.
IEC 801-4	Electrical Fast Transient/Burst.
IEC 805-1	Surge.
EN 55011/CISPR 11	Electromagnetic Susceptibility.
EN 60601-1/IEC 601-1/UL 2601-1	Medical Electrical Equipment; General Requirements for Safety.
EN 61157/ IEC 61157	Requirements for the declaration of the acoustic output of medical diagnostic ultrasonic equipment.

NOTE: *For CE Compliance, it is critical that all covers, screws, shielding, gaskets, mesh and clamps are in good condition and installed tightly without skew or stress. Proper installation following all comments noted in this service manual is required in order to achieve full EMC performance.*

1-5-4 Lockout/Tagout Requirements (For USA Only)

Follow OSHA Lockout/Tagout requirements by ensuring you are in total control of the electrical Mains plug.

Section 1-6 Customer Assistance

1-6-1 Contact Information

If this equipment does not work as indicated in this service manual or in the *Vivid™ 3 Pro/Vivid™ 3 Expert User Manual*, or if you require additional assistance, please contact the local distributor or appropriate support resource, as listed below.

Prepare the following information before you call:

- System ID and/or serial number.
- Software version.

Table 1-9 GE Contact Information

Location	Phone Number
USA/ Canada GE Medical Systems Ultrasound Service Engineering 4855 W. Electric Avenue Milwaukee, WI 53219 Customer Answer Center	Phone: +1-800-437-1171 Phone: +1-800-321-7937 Phone: +1-800-682-5327 Phone: +1-262-524-5698 Fax: +1-414-647-4125
Latin America GE Medical Systems Ultrasound Service Engineering 4855 W. Electric Avenue Milwaukee, WI 53219 Customer Answer Center	Phone: +1-262-524-5300 Phone: +1-262-524-5698 Fax: +1-414-647-4125
Europe GE Ultraschall Deutschland GmbH & Co. KG BeethovenstraBe 239 Postfach 11 05 60, D-42665 Solingen Germany	General Imaging: +49 (212) 2802 207 Cardiac: +49 (212) 2802 208 Fax: +49 212 2802 431
Asia (Singapore/ Japan) GE Ultrasound Asia Service Department - Ultrasound 298 Tiong Bahru Road #15-01/06 Central Plaza Singapore 169730	Phone: +65-277-3487 Fax: +65-272-3997 Phone: +81-426-48-2950 Fax: +81-426-48-2902

Chapter 2

Pre-Installation

Section 2-1 Overview

2-1-1 Purpose of Chapter 2

This chapter provides the information required to plan and prepare for the installation of a Vivid™ 3 ultrasound unit. Included are descriptions of the electrical and facility requirements that must be met by the purchaser. A worksheet is provided at the end of this chapter (see [Figure 2-2](#) on page 2-11) to help ensure that all the required network information is available, prior to installation.

Table 2-1 Contents in Chapter 2

Section	Description	Page Number
2-1	Overview	2-1
2-2	Console Requirements	2-2
2-3	Facility Needs	2-7

Section 2-2 Console Requirements

2-2-1 Unit Environmental Requirements

Table 2-2 Environmental Requirements

Requirement	Temperature	Relative Humidity (non-condensing)	Air Pressure
Operational	10 — 40°C (50 — 104°F)	50 — 70%	700 — 1060 hPa
Storage	-20 — 60°C (-4 — 140°F)	10 — 95%	700 — 1060 hPa
Transport	-20 — 60°C (-4 — 140°F)	10 — 95%	700 — 1060 hPa



CAUTION: If the system has been in storage or has been transported, please see the acclimation requirements *before* powering ON and/or using the system. Refer to the [Installation Warnings](#) section on page 3-2.

2-2-2 Cooling Requirements

The cooling requirement for the Vivid™ 3 ultrasound unit environment is 3500 BTU/hr. This figure does not include the cooling required for lights, people, or other equipment in the room.

Note: Each person in the room places an additional 300 BTU/hr demand on the environmental cooling.

2-2-3 Lighting Requirements

For system installation, updates and repairs, bright lighting is required. However, operator and patient comfort may be optimized if the room lighting is subdued and indirect when a scan is being performed. Therefore, a combination lighting system (dim/bright) is recommended. Keep in mind that lighting controls and dimmers can be a source of EMI which could degrade image quality. These controls should be selected to minimize possible interference.

2-2-4 Time and Manpower Requirements

Site preparation takes time. Begin pre-installation checks as soon as possible to allow sufficient time to make any required changes. If possible, begin these checks as many as six weeks before system delivery.



CAUTION: At least two people must be available to deliver and unpack the Vivid™ 3 ultrasound unit. Attempts to move the unit considerable distances (or on an incline) by one person alone, could result in personal injury, and/or damage to the system.



2-2-5 Electrical Requirements

NOTE: GE Medical Systems requires a dedicated power and Ground for the proper operation of its Ultrasound equipment. This dedicated power shall originate at the last distribution panel before the system.

Sites with a mains power system with defined Neutral and Live:

The dedicated line shall consist of one phase, a neutral (not shared with any other circuit), and a full size Ground wire from the distribution panel to the Ultrasound outlet.

Sites with a mains power system without a defined Neutral:

The dedicated line shall consist of one phase (two lines), not shared with any other circuit, and a full size Ground wire from the distribution panel to the Ultrasound outlet.

NOTE: Please note that image artifacts can occur, if at any time within the facility, the Ground from the main facility's incoming power source to the Ultrasound unit is only a conduit.

2-2-5-1 Vivid™ 3 Power Requirements

Electrical specifications for the Vivid™ 3 monitor and onboard peripherals are as follows:

Table 2-3 Electrical Requirements

Voltage	Tolerances	Op. Current	Frequency
100V AC	±10%	8A	50-60 Hz
120V AC	±10%	8A	50-60 Hz
220 - 240V AC	±10%	4A	50-60 Hz

2-2-5-2 Inrush Current

Inrush current is not a factor for consideration, due to the inrush current limiting properties of the power supplies.

Maximum power requirement = 1.2 KVa

- 100V AC: 8A
- 120V AC: 8A
- 220 - 240V AC: 4A

2-2-5-3 Site Circuit Breaker

It is recommended that the branch circuit breaker for the machine be readily accessible.



CAUTION POWER OUTAGE MAY OCCUR.

The Vivid 3 requires a dedicated single branch circuit. To avoid circuit overload and possible loss of critical care equipment, make sure you DO NOT have any other equipment operating on the same circuit.

2-2-5-4 Site Power Outlets

A dedicated AC power outlet must be within reach of the unit without requiring the use of extension cords. Other outlets adequate for the external peripherals, medical and test equipment required to support this unit must also be present and located within 1 m (3.2 ft) of the unit. Electrical installation must meet all current local, state, and national electrical codes.

2-2-5-5 Mains Power Plug

If the unit arrives without a power plug, or with the wrong plug, contact your GE dealer. When necessary, the installation engineer will supply the locally-required power plug.

2-2-5-6 Power Stability Requirements

Voltage drop-out

Max 10 ms.

NOTE: The Vivid™ 3 ultrasound unit can be provided with an external UPS system. Contact your local GE Service Representative for details.

Power Transients

(All applications)

Less than 25% of nominal peak voltage for less than 1 millisecond for any type of transient, including line frequency, synchronous, asynchronous, or aperiodic transients.

2-2-6 EMI Limitations

Ultrasound machines are susceptible to Electromagnetic Interference (EMI) from radio frequencies, magnetic fields, and transients in the air or wiring. They also generate EMI. The Vivid™ 3 ultrasound unit complies with limits as stated on the EMC label. However, there is no guarantee that interference will not occur in a particular installation.

Note: Possible EMI sources should be identified before the unit is installed, and should not be on the same line as the ultrasound system. A dedicated line should be used for the ultrasound system.

Electrical and electronic equipment may produce EMI unintentionally as the result of a defect. Sources of EMI include the following:

- Medical lasers.
- Scanners.
- Cauterizing guns.
- Computers.
- Monitors.
- Fans.
- Gel warmers.
- Microwave ovens.
- Portable phones.
- Broadcast stations and mobile broadcasting machines.

The following table lists recommendations for preventing EMI:

Table 2-4 EMI Prevention/ Abatement

EMI Rule	Details
Ground the unit.	Poor grounding is the most likely reason an ultrasound unit will have noisy images. Check the grounding of the power cord and power outlet.
Be aware of RF sources.	Keep the unit at least 5m (16.4 ft) away from other EMI sources. Special shielding may be required to eliminate interference problems caused by high frequency, high powered radio or video broadcast signals.
Replace and/or reassemble all screws, RF gaskets, covers and cores.	After you finish repairing or updating the system, replace all covers and tighten all screws. Any cable with an external connection requires a magnet wrap at each end. Install the shield over the front of the card cage. Loose or missing covers or RF gaskets allow radio frequencies to interfere with the ultrasound signals.
Replace broken RF gaskets.	If more than 20% or a pair of the fingers on an RF gasket are broken, replace the gasket. Do not turn ON the unit until any loose metallic part is removed and replaced, if required.
Do not place labels where RF gaskets touch metal.	Never place a label where RF gaskets meet the unit. Otherwise, the gap created will permit RF leakage. In case a label has been found in such a location, move the label to a different, appropriate location.
Use GE specified harnesses and peripherals.	The interconnect cables are grounded and require ferrite beads and other shielding. Cable length, material, and routing are all important; do not make any changes that do not meet all specifications.
Take care with cellular phones.	Cellular phones may transmit a 5 V/m signal that causes image artifacts.
Properly address peripheral cables.	Do not allow cables to lie across the top of the card cage or hang out of the peripheral bays. Loop any peripheral cable excess length inside the peripheral bays or hang on the hooks provided below the console. Attach the monitor cables to the frame.

2-2-7 Probe Environmental Requirements

Table 2-5 Probe Operation and Storage Temperatures

	Electronics	PAMPTE
Operation	10 — 40°C (50 — 104°F)	5 — 42.7°C (41 — 109°F)
Storage	-20 — 50°C (-4 — 122°F)	-20 — 50°C (-4 — 122°F)

Note: System and electronic probes are designed for storage temperatures of -20° to +50° C. When exposed to large temperature variations, the probes should be kept at room temperature for a *minimum* of **10 hours** before use.

Section 2-3 Facility Needs

2-3-1 Purchaser Responsibilities

The work and materials required to prepare the site are the responsibility of the purchaser. To avoid delay, complete all pre-installation work before delivery. Use the Pre-installation Check List (provided in [Table 2-6 on page 2-12](#)) to verify that all the required steps have been completed.

Purchaser responsibilities include:

- Procuring the required materials.
- Completing the preparations prior to delivery of the ultrasound system.
- Paying the costs of any alterations and modifications not specifically provided for in the sales contract.

Note: All relevant preliminary electrical installations at the prepared site must be performed by licensed electrical contractors. Other connections between electrical equipment, and calibration and testing, must also be performed by qualified personnel. The products involved (and the accompanying electrical installations) are highly sophisticated and special engineering competence is required. All electrical work on these products must comply with the requirements of applicable electrical codes. The purchaser of GE equipment must utilize only qualified personnel to perform electrical servicing of the equipment.

To avoid delays during installation, the individual or team who will perform the installation should be notified at the earliest possible date (preferably prior to installation), of the existence of any of the following variances:

- Use of any non-listed product(s).
- Use of any customer provided product(s).
- Placement of an approved product further from the system than the interface kit allows.

The prepared site must be clean prior to delivery of the system. Carpeting is not recommended because it collects dust and creates static. Potential sources of EMI should also be investigated before delivery. Dirt, static, and EMI can negatively impact system reliability.

2-3-2 Mandatory Site Requirements

The following are mandatory site requirements. Additional (optional) recommendations, as well as a recommended ultrasound room layout, are provided in section [2-3-3 - Site Recommendations](#) (see below).

- A dedicated single branch power outlet of adequate amperage (see [Table 2-3 on page 2-3.](#)) that meets all local and national codes and is located less than 2.5 m (8.2 ft) from the unit's proposed location. Refer to the [Electrical Requirements](#) section on page 2-3.
- A door opening of at least 76 cm (2.5 ft) in width.
- The proposed location for the unit is at least 0.3 m (1 ft) from the walls, to enable cooling.
- Power outlets for other medical equipment and gel warmer.
- Power outlets for test equipment within 1 m (3.3 ft) of the ultrasound unit.
- Clean and protected space for storage of probes (either in their case or on a rack).
- Material to safely clean probes.
- In the case of a network option:
 - An active network outlet in the vicinity of the ultrasound unit.
 - A network cable of appropriate length (regular Pin-to-Pin network cable).
 - An IT administrator who will assist in configuring the unit to work with your local network. A fixed IP address is required. Refer to the form provided in [Figure 2-2](#) on page 2-11 for network details that are required.

Note: All relevant preliminary network outlets installations at the prepared site must be performed by authorized contractors. The purchaser of GE equipment must utilize only qualified personnel to perform servicing of the equipment.

2-3-3 Site Recommendations

The following are (optional) site recommendations. Mandatory site requirements are provided in the [Mandatory Site Requirements](#) section, above.

- A door opening of 92 cm (3 ft) in width.
- An accessible circuit breaker for a dedicated power outlet.
- A sink with hot and cold running water.
- A receptacle for bio-hazardous waste, for example, used probe sheaths.
- An emergency oxygen supply.
- A storage area for linens and equipment.
- A nearby waiting room, lavatory, and dressing room.
- Dual level lighting (bright and dim).
- A lockable cabinet for software and manuals.

2-3-3-1 Recommended Ultrasound Room Layout

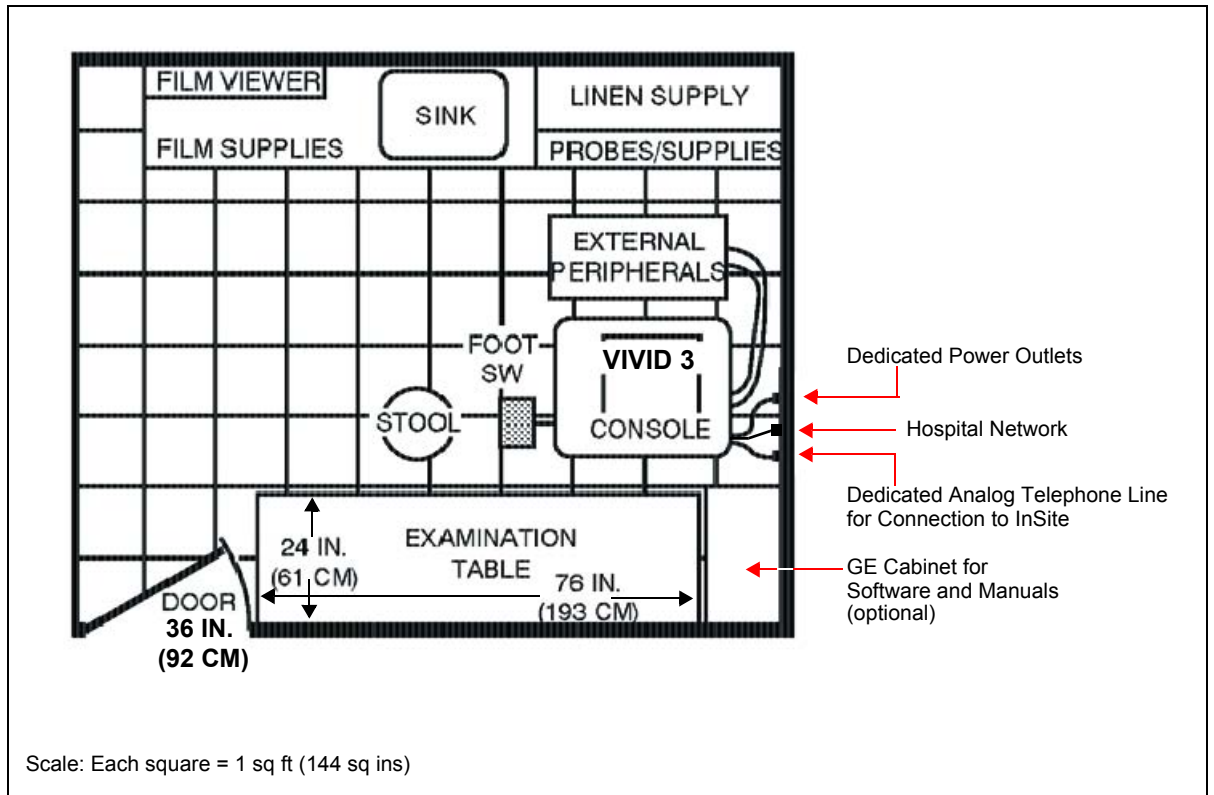

Figure 2-1 Minimal Floor Plan 2.5m x 3m (8.2ft x 9.84 ft)

2-3-4 Networking Pre-Installation Requirements

2-3-4-1 Stand-alone Unit (without Network Connection)

None.

2-3-4-2 Unit Connected to Hospital's Network

Supported networks:

- 100/10 Mbit/sec

2-3-4-3 Purpose of the DICOM Network Function

DICOM services provide the operator with clinically useful features for moving images and patient information over a hospital network. Examples of DICOM services include the transfer of images to workstations for viewing or transferring images to remote printers. As an added benefit, transferring images in this manner frees up the on-board monitor and peripherals, enabling viewing to be done while scanning continues. With DICOM, images can be archived, stored, and retrieved faster, easier, and at a lower cost.

2-3-4-4 DICOM Option Pre-Installation Requirements

To configure the Vivid™ 3 ultrasound unit to work with other network connections, the network administrator must provide the required information, which should include the following:

- **Vivid™ 3 Details:** DICOM network details for the Vivid™ 3 unit, including the host name, local port, IP address, AE title and net mask.
- **Routing Information:** IP addresses for the default gateway and other routers in use at the site.
- **DICOM Application Information:** Details of the DICOM devices in use at the site, including the DICOM host name, AE title and IP addresses.

Section 2-4 Connectivity Installation Worksheet

Site System Information					
Site: <input style="width: 90%;" type="text"/>	Floor: <input style="width: 80%;" type="text"/>	Comments: <div style="border: 1px solid black; height: 100px; width: 100%;"></div>			
Dept: <input style="width: 90%;" type="text"/>	Room: <input style="width: 80%;" type="text"/>				
Vivid™ 3 SN: <input style="width: 80%;" type="text"/> Type: <input style="width: 80%;" type="text"/>	REV: <input style="width: 80%;" type="text"/>				
CONTACT INFORMATION					
Name	Title	Phone	E-Mail Address		
<input style="width: 100%; height: 20px;" type="text"/>	<input style="width: 100%; height: 20px;" type="text"/>	<input style="width: 100%; height: 20px;" type="text"/>	<input style="width: 100%; height: 20px;" type="text"/>		
<input style="width: 100%; height: 20px;" type="text"/>	<input style="width: 100%; height: 20px;" type="text"/>	<input style="width: 100%; height: 20px;" type="text"/>	<input style="width: 100%; height: 20px;" type="text"/>		
<input style="width: 100%; height: 20px;" type="text"/>	<input style="width: 100%; height: 20px;" type="text"/>	<input style="width: 100%; height: 20px;" type="text"/>	<input style="width: 100%; height: 20px;" type="text"/>		
<input style="width: 100%; height: 20px;" type="text"/>	<input style="width: 100%; height: 20px;" type="text"/>	<input style="width: 100%; height: 20px;" type="text"/>	<input style="width: 100%; height: 20px;" type="text"/>		
TCP/IP Settings					
Scanner IP Settings			Remote Archive Setup (Echo Server/GEMNet Server/EchoPac PC)		
Name - AE Title: <input style="width: 90%;" type="text"/>			Name - AE Title: <input style="width: 90%;" type="text"/>		
IP Address: <input style="width: 20%;" type="text"/> <input style="width: 20%;" type="text"/> <input style="width: 20%;" type="text"/> <input style="width: 20%;" type="text"/>			IP Address: <input style="width: 20%;" type="text"/> <input style="width: 20%;" type="text"/> <input style="width: 20%;" type="text"/> <input style="width: 20%;" type="text"/>		
Subnet Mask: <input style="width: 20%;" type="text"/> <input style="width: 20%;" type="text"/> <input style="width: 20%;" type="text"/> <input style="width: 20%;" type="text"/>			Subnet Mask: <input style="width: 20%;" type="text"/> <input style="width: 20%;" type="text"/> <input style="width: 20%;" type="text"/> <input style="width: 20%;" type="text"/>		
Default Gateway: <input style="width: 20%;" type="text"/> <input style="width: 20%;" type="text"/> <input style="width: 20%;" type="text"/> <input style="width: 20%;" type="text"/>			Default Gateway: <input style="width: 20%;" type="text"/> <input style="width: 20%;" type="text"/> <input style="width: 20%;" type="text"/> <input style="width: 20%;" type="text"/>		
			Server Name: <input style="width: 90%;" type="text"/>		
			Remote DB User Name: <input style="width: 90%;" type="text"/>		
Services (Destination Devices)					
Device Type	Manufacturer	Name	IP Address	Port	AE Title
1	<input style="width: 100%; height: 20px;" type="text"/>	<input style="width: 100%; height: 20px;" type="text"/>	<input style="width: 20%;" type="text"/> <input style="width: 20%;" type="text"/> <input style="width: 20%;" type="text"/> <input style="width: 20%;" type="text"/>	<input style="width: 20%;" type="text"/>	<input style="width: 100%; height: 20px;" type="text"/>
2	<input style="width: 100%; height: 20px;" type="text"/>	<input style="width: 100%; height: 20px;" type="text"/>	<input style="width: 20%;" type="text"/> <input style="width: 20%;" type="text"/> <input style="width: 20%;" type="text"/> <input style="width: 20%;" type="text"/>	<input style="width: 20%;" type="text"/>	<input style="width: 100%; height: 20px;" type="text"/>
3	<input style="width: 100%; height: 20px;" type="text"/>	<input style="width: 100%; height: 20px;" type="text"/>	<input style="width: 20%;" type="text"/> <input style="width: 20%;" type="text"/> <input style="width: 20%;" type="text"/> <input style="width: 20%;" type="text"/>	<input style="width: 20%;" type="text"/>	<input style="width: 100%; height: 20px;" type="text"/>
4	<input style="width: 100%; height: 20px;" type="text"/>	<input style="width: 100%; height: 20px;" type="text"/>	<input style="width: 20%;" type="text"/> <input style="width: 20%;" type="text"/> <input style="width: 20%;" type="text"/> <input style="width: 20%;" type="text"/>	<input style="width: 20%;" type="text"/>	<input style="width: 100%; height: 20px;" type="text"/>
5	<input style="width: 100%; height: 20px;" type="text"/>	<input style="width: 100%; height: 20px;" type="text"/>	<input style="width: 20%;" type="text"/> <input style="width: 20%;" type="text"/> <input style="width: 20%;" type="text"/> <input style="width: 20%;" type="text"/>	<input style="width: 20%;" type="text"/>	<input style="width: 100%; height: 20px;" type="text"/>
6	<input style="width: 100%; height: 20px;" type="text"/>	<input style="width: 100%; height: 20px;" type="text"/>	<input style="width: 20%;" type="text"/> <input style="width: 20%;" type="text"/> <input style="width: 20%;" type="text"/> <input style="width: 20%;" type="text"/>	<input style="width: 20%;" type="text"/>	<input style="width: 100%; height: 20px;" type="text"/>
7	<input style="width: 100%; height: 20px;" type="text"/>	<input style="width: 100%; height: 20px;" type="text"/>	<input style="width: 20%;" type="text"/> <input style="width: 20%;" type="text"/> <input style="width: 20%;" type="text"/> <input style="width: 20%;" type="text"/>	<input style="width: 20%;" type="text"/>	<input style="width: 100%; height: 20px;" type="text"/>
8	<input style="width: 100%; height: 20px;" type="text"/>	<input style="width: 100%; height: 20px;" type="text"/>	<input style="width: 20%;" type="text"/> <input style="width: 20%;" type="text"/> <input style="width: 20%;" type="text"/> <input style="width: 20%;" type="text"/>	<input style="width: 20%;" type="text"/>	<input style="width: 100%; height: 20px;" type="text"/>
9	<input style="width: 100%; height: 20px;" type="text"/>	<input style="width: 100%; height: 20px;" type="text"/>	<input style="width: 20%;" type="text"/> <input style="width: 20%;" type="text"/> <input style="width: 20%;" type="text"/> <input style="width: 20%;" type="text"/>	<input style="width: 20%;" type="text"/>	<input style="width: 100%; height: 20px;" type="text"/>
10	<input style="width: 100%; height: 20px;" type="text"/>	<input style="width: 100%; height: 20px;" type="text"/>	<input style="width: 20%;" type="text"/> <input style="width: 20%;" type="text"/> <input style="width: 20%;" type="text"/> <input style="width: 20%;" type="text"/>	<input style="width: 20%;" type="text"/>	<input style="width: 100%; height: 20px;" type="text"/>
11	<input style="width: 100%; height: 20px;" type="text"/>	<input style="width: 100%; height: 20px;" type="text"/>	<input style="width: 20%;" type="text"/> <input style="width: 20%;" type="text"/> <input style="width: 20%;" type="text"/> <input style="width: 20%;" type="text"/>	<input style="width: 20%;" type="text"/>	<input style="width: 100%; height: 20px;" type="text"/>
12	<input style="width: 100%; height: 20px;" type="text"/>	<input style="width: 100%; height: 20px;" type="text"/>	<input style="width: 20%;" type="text"/> <input style="width: 20%;" type="text"/> <input style="width: 20%;" type="text"/> <input style="width: 20%;" type="text"/>	<input style="width: 20%;" type="text"/>	<input style="width: 100%; height: 20px;" type="text"/>

Figure 2-2 Connectivity Installation Worksheet

Table 2-6 Pre-Installation Check List

Action	Yes	No
Schedule at least 3 hours for installation of the system.		
Notify installation team of the existence of any variances from the basic installation.		
Make sure system and probes have been subject to acclimation period.		
Environmental cooling is sufficient.		
Lighting is adjustable to adapt to varying operational conditions of the scanner.		
Electrical facilities meet system requirements.		
EMI precautions have been taken and all possible sources of interference have been removed.		
Mandatory site requirements have been met.		
If a network is used, IP address has been set for the system and a dedicated network outlet is available.		

Chapter 3

Installation

Section 3-1 Overview

3-1-1 Purpose of Chapter 3

This chapter provides instructions for installing the Vivid™ 3 ultrasound unit. Before beginning the installation process, an appropriate site must be prepared, as described in *Chapter 2 - Pre-Installation*. Once the site has been prepared, installation can proceed as described in this chapter.

Table 3-1 Contents in Chapter 3

Section	Description	Page Number
3-1	Overview	3-1
3-2	Installation Reminders	3-2
3-3	Receiving and Unpacking the Equipment	3-4
3-4	Preparing for Installation	3-13
3-5	Completing the Hardware Installation	3-22
3-6	System Configuration	3-35
3-7	Connectivity Setup	3-50
3-8	Storing and Transporting the Unit	3-68
3-9	Completing the Installation Paperwork	3-76

Section 3-2 Installation Reminders

3-2-1 Average Installation Time

Once the site has been prepared, the average installation time required is shown in [Table 3-2](#) below.

Table 3-2 Average Installation Time

Description	Average Installation Time	Comments
Unpacking the scanner	0.5 hour	
Installing the scanner	0.5 hour	Time may vary, according to the required configuration
DICOM Option (connectivity)	0.5 - 2.0 hours	Time may vary, according to the required configuration

3-2-2 Installation Warnings

- 1.) Since the Vivid™ 3 weighs 160 kg (353 lbs) or more, without options, two persons are always required to unpack it. This is also applicable when installing any additional items in excess of 16 kg (35 lbs).
- 2.) There are no operator-serviceable components. To prevent shock, do not remove any covers or panels. Should problems or malfunctions occur, unplug the power cord. Only qualified service personnel should carry out servicing and troubleshooting.

3-2-2-1 System Acclimation Time

Following transport, the Vivid™ 3 system may be very cold, or hot. Allow time for the system to acclimate before being switched ON. Acclimation requires 1 hour for each 2.5°C increment, when the temperature of the system is below 10°C or above 35°C.

CAUTION Turning the system ON after arrival at the site - without allowing time for acclimation - may cause system damage!

Table 3-3 Vivid™ 3 System Acclimation Time

°C	60	55	50	45	40	35	30	25	20	15	10	5	0	-5	-10	-15	-20	-25	-30	-35	-40
°F	140	131	122	113	104	96	86	77	68	59	50	41	32	23	14	5	-4	-13	-22	-31	-40
Hrs	8	6	4	2	0	0	0	0	0	0	0	2	4	6	8	10	12	14	16	18	20

3-2-3 Safety Reminders



DANGER: WHEN USING ANY TEST INSTRUMENT THAT IS CAPABLE OF OPENING THE AC GROUND LINE (I.E., METER'S GROUND SWITCH IS OPEN), DO NOT TOUCH THE UNIT!



WARNING: Two people are required to unpack the unit, as it is heavy. Two people are also required whenever a part weighing 19kg (35 lb.) or more must be lifted.



CAUTION: If the unit is very cold or hot, do NOT turn ON power to the unit until it has had sufficient time to acclimate to its operating environment.



CAUTION: To prevent electrical shock, connect the unit to a properly grounded power outlet. Do NOT use a three-prong to two-prong adapter, as this defeats safety grounding.



CAUTION: Do NOT wear the ESD wrist strap when you work on live circuits where more than 30 V peak is present.



CAUTION: Do NOT operate the unit unless all board covers and frame panels are securely in place, to ensure optimal system performance and cooling. When covers are removed, EMI may be present.



WARNING: ACOUSTIC OUTPUT HAZARD
Although the ultrasound energy transmitted from the Vivid™ 3 ultrasound unit is within AIUM/NEMA standards and FDA limitations, avoid unnecessary exposure. Ultrasound energy can produce heat and mechanical damage.

Note: The *Vivid™ 3 Pro/Vivid™ 3 Expert User Manual* should be fully read and understood before operating the unit. Keep the manual near the unit for reference.

Section 3-3 Receiving and Unpacking the Equipment



CAUTION: Please read this section fully before unpacking the Vivid™ 3 ultrasound unit.

Note:

The Vivid™ 3 ultrasound unit is shipped from the factory either in a wooden shipping crate, or in a cardboard shipping carton. Separate instructions are provided for opening and unpacking each type of container, as follows:

- [Unpacking the Wooden Shipping Crate](#) - see [section 3-3-1](#) below.
- [Unpacking the Cardboard Shipping Carton](#) - see [section 3-3-2](#) on page 3-9.

3-3-1 Unpacking the Wooden Shipping Crate

The Vivid™ 3 ultrasound unit is packed in a wooden crate that has four walls (*left, right, front and rear*), the crate base, and the top cover. Each section has rebated joints that are joined together with Clip-lok™ clips.

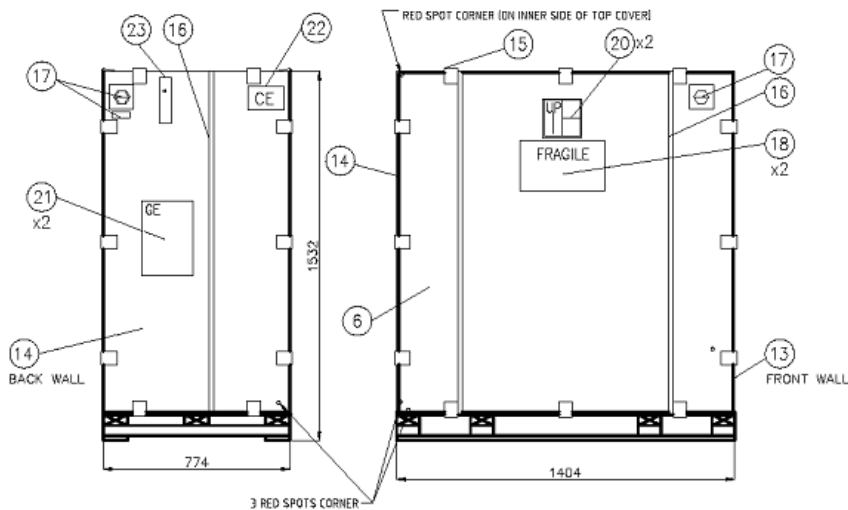

Figure 3-1 Vivid™ 3 - Wooden Shipping Crate

3-3-1-1 Removing the Clip-lok™ Clips

When unpacking the Vivid™ 3 ultrasound unit, always remove the Clip-lok™ clips as follows:

- 1) Locate and remove the clip remover tool (item 23) that is secured on the outside of the wooden crate, as shown in [Figure 3-1](#), above.
- 2) Insert the hand level of the clip remover tool under the flange of the long leg of the clip.
- 3) Place your free hand over the clip to prevent injury when the clip is removed.
- 4) Rock the lever downwards towards the edge of the case, to remove the clip.

3-3-1-2 Unpacking and Removing the Unit from the Wooden Crate

Before unpacking the unit, inspect the wooden crate for damage. Inspect the *Drop and Tilt* indicators (on the Shock-watch and Tilt-watch labels, respectively) for evidence of accidental shock or tilting of the crate during transit - see [Figure 3-2](#) below).

NOTE: *If the crate is damaged, or if either the Drop or Tilt indicators have turned red (showing failure), please inform the GE Medical Systems sales representative immediately. In addition, mark on the shipping consignment note or packing slip/post-delivery checklist (in the "Package" column) that the Tilt and/or Drop indicators show failure.*

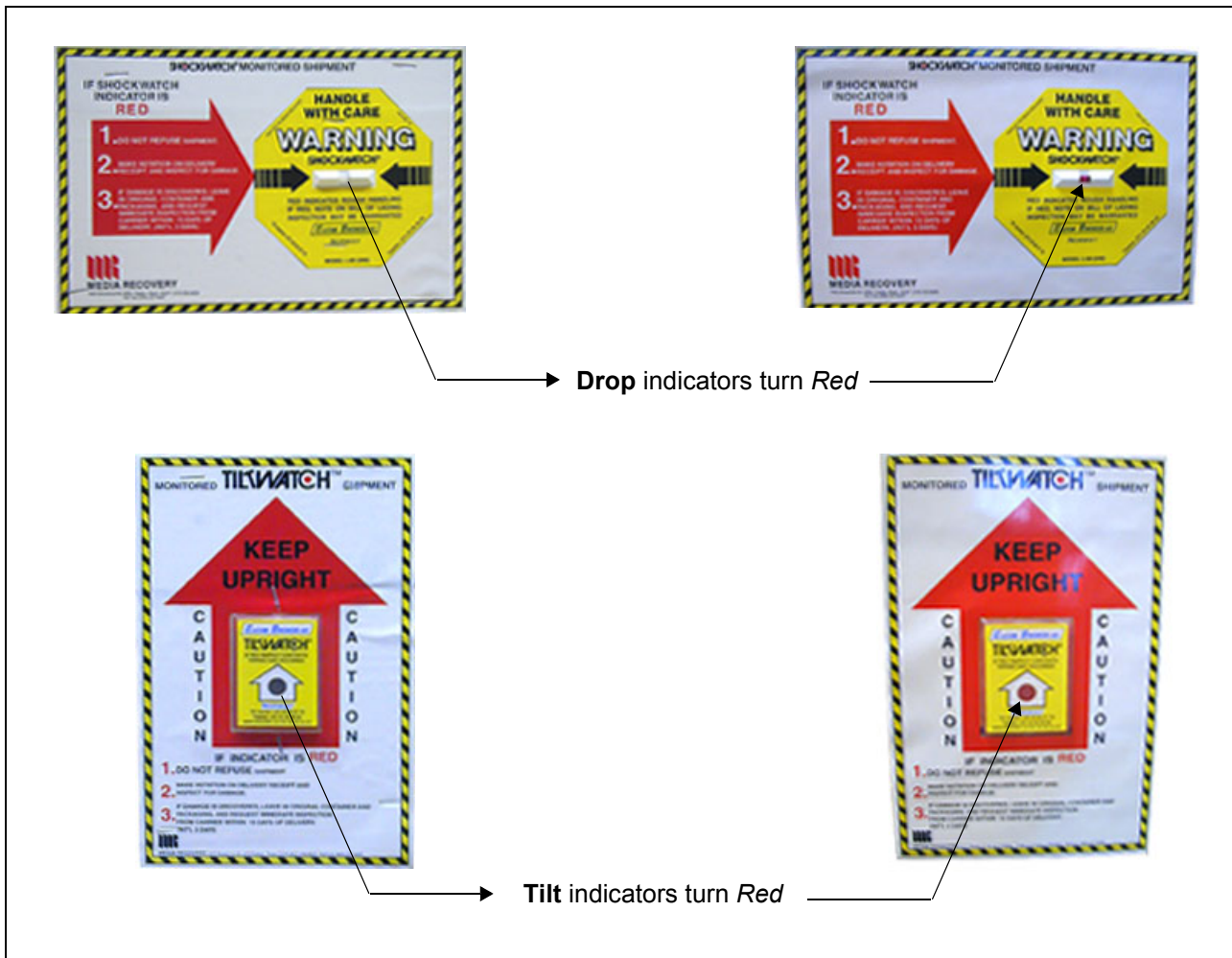

Figure 3-2 Drop and Tilt Indicators

It is recommended to keep and store the crate and all other packing materials (including the Clip-lok™ clips, support foams, anti-static plastic cover, etc.), in the event that transport or shipment of the unit to a different location will be required in the future.



CAUTION: When using sharp tools to open packing materials, take care to avoid cutting or damaging the contents.

Note: Unless otherwise specified, referenced items are shown in [Figure 3-1](#) on page 3-4.

- 1) Cut and remove the three securing steel strips (item 16).
- 2) Release the eight Clip-lok™ clips (item 15) securing the front wall (item 13) and remove the front wall. (Refer to the procedure described in [Section 3-3-1-1](#) on page 3-4).
- 3) Release the eight Clip-lok™ clips securing the back wall (item 14) and remove the back wall.
- 4) Remove the small cartons containing the probes and peripheral options (items D and E in [Figure 3-3](#) below) from the wooden crate.

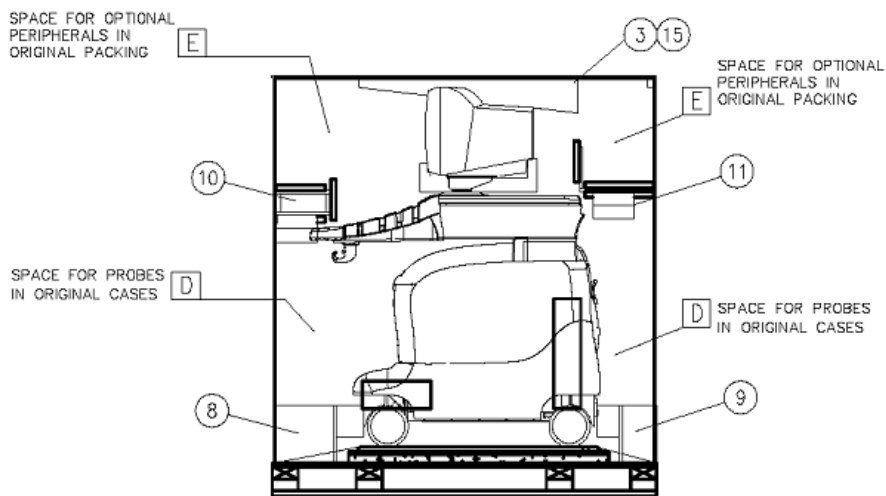

Figure 3-3 Probes and Peripherals in Original Packaging

- 5) Remove the console control support back foam (item 11 in [Figure 3-3](#), above).
- 6) Remove the keyboard support foam located in front of the keyboard (item 10 in [Figure 3-3](#), above).
- 7) Remove the back support foam located in front of the rear wheels (item 9 in [Figure 3-3](#), above).
- 8) Remove the top cover by opening the six clips fastening it to the *right* and *left* walls. For details on opening the clips, refer to [Section 3-3-1-1](#) on page 3-4.
- 9) Remove the *right* wall (item 6) and the *left* wall (item 7) by opening the three clips fastening each to the base.
- 10) Cut and remove the antistatic sheet (item 2 in [Figure 3-4](#) below) that is wrapped around the unit, taking care not to damage the antistatic cover.
- 11) Remove the antistatic cover (item 4 in [Figure 3-4](#)).

- 12) Remove the two monitor foam supports (item 12 in Figure 3-4), located one on each side of the monitor.

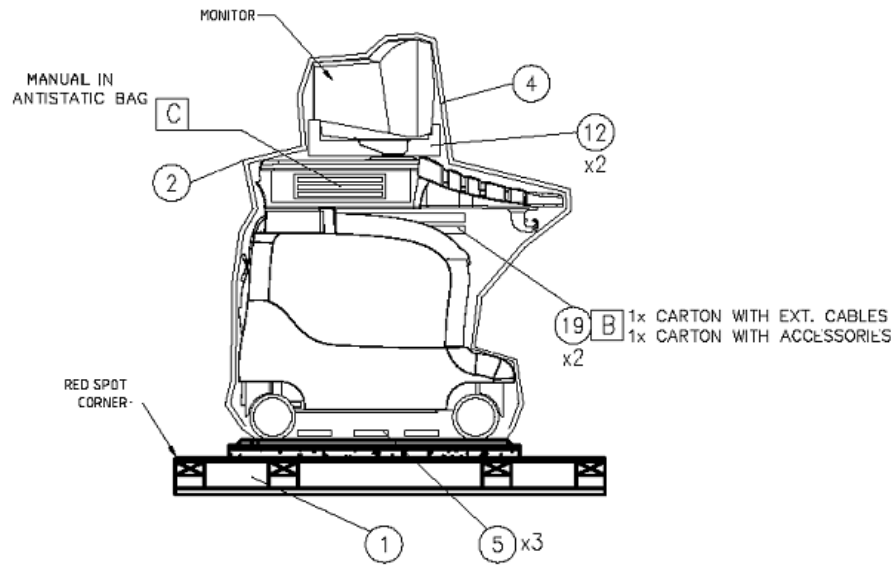

Figure 3-4 Antistatic Cover, Supports and Accessories

- 13) Remove the three silica gel (moisture absorbing) bags (item 5 in Figure 3-4, above) located under the unit.
- 14) Raise the control console (monitor) by pressing the release grip located under the unit's front handle.
- 15) Remove the two cartons containing the external cables and accessories located under the control console, and then lower the control console.
- 16) Lay the top cover (removed from the crate in step 8 on page 3-6) on the floor and push it over the narrow side of the base, in front of the unit, to act as a ramp (item 3 in Figure 3-5 below).

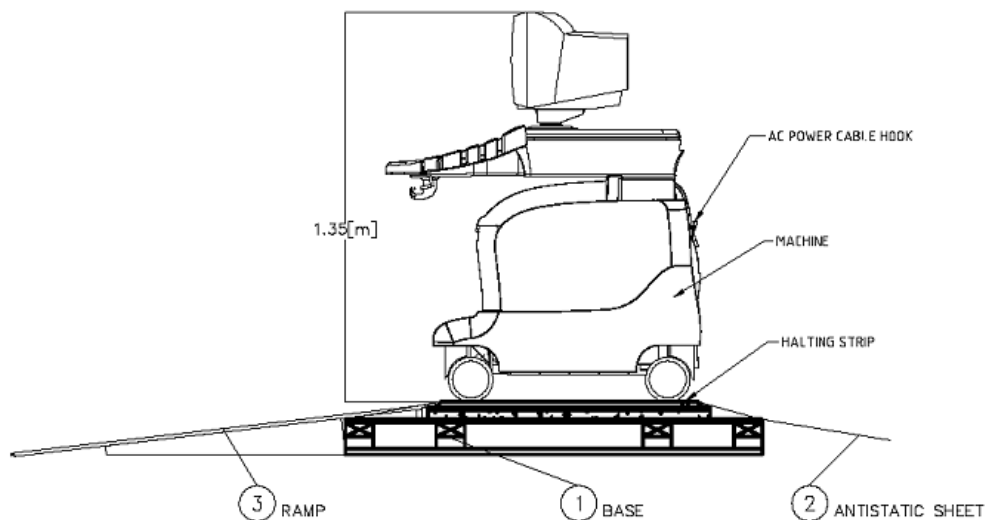

Figure 3-5 Removing the Unit from the Wooden Crate

- 17) Press the brake pedal, located near the bottom of the front of the unit, to the right, to prevent the wheels from swiveling, as described in the *Swivel Brake Label* section, page 1-24.
- 18) Pull the unit backwards from the platform base onto the ramp and roll it down to the floor.
- 19) Press the brake pedal, located near the bottom of the front of the unit, to the left, to lock the wheels, as described in the *Parking Label* section, page 1-24.
- 20) Verify the contents of the case, as described in *Verifying the Shipping Crate Contents* on page 3-13.

3-3-2 Unpacking the Cardboard Shipping Carton

The Vivid™ 3 ultrasound unit is packed in a cardboard shipping carton comprising a durable outer cardboard carton cover, and a wooden platform base; these are firmly joined together with clamps and screws. A ramp for rolling the Vivid™ 3 ultrasound unit off the platform, is also included.

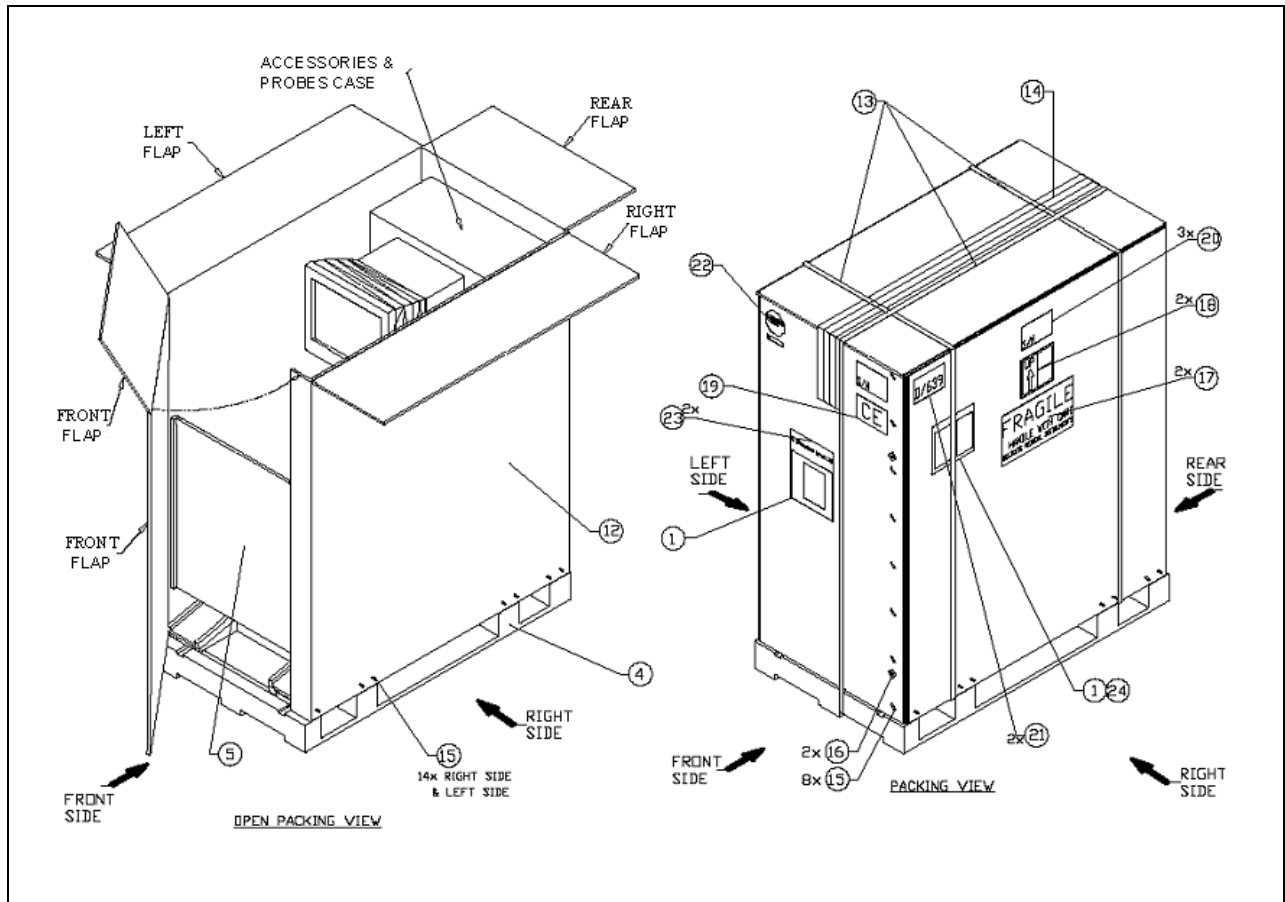

Figure 3-6 Vivid™ 3 - Cardboard Shipping Carton

3-3-3 Unpacking and Removing the Unit from the Cardboard Shipping Carton

Before unpacking the unit, inspect the carton case for damage. Inspect the *Drop and Tilt* indicators (on the Shock-watch and Tilt-watch labels, respectively) for evidence of accidental shock or tilting of the crate during transit - refer to [Figure 3-2](#) on page 3-5.

NOTE: *If the crate is damaged, or if either the Drop or Tilt indicators have turned red (showing failure), please inform the GE Medical Systems sales representative immediately. In addition, mark on the shipping consignment note or packing slip/post-delivery checklist (in the "Package" column) that the Tilt and/or Drop indicators show failure.*

It is recommended to keep and store the cardboard shipping carton and all other packing materials (including the support foams, anti-static plastic cover, etc., in the event that transport or shipment of the unit to a different location will be required in the future.



CAUTION: When using sharp tools to open packing materials, take care to avoid cutting or damaging the contents.

Note: Unless otherwise specified, referenced items are shown in [Figure 3-6](#) on page 3-9.

- 1) Cut and remove the three securing steel strips (item 13).
- 2) Cut the adhesive tape along the center of the top of the cardboard shipping carton (item 14).
- 3) Remove all the fastening staples (item 15) and remove the two screws (item 16) so that the cardboard carton (item 12) is free of the wooden platform (item 4), and the narrow flap is free.
- 4) Open the narrow side flap of the carton, remove the ramp (item 5) and attach it to the narrow side of the wooden platform (item 4 in [Figure 3-7](#) below).

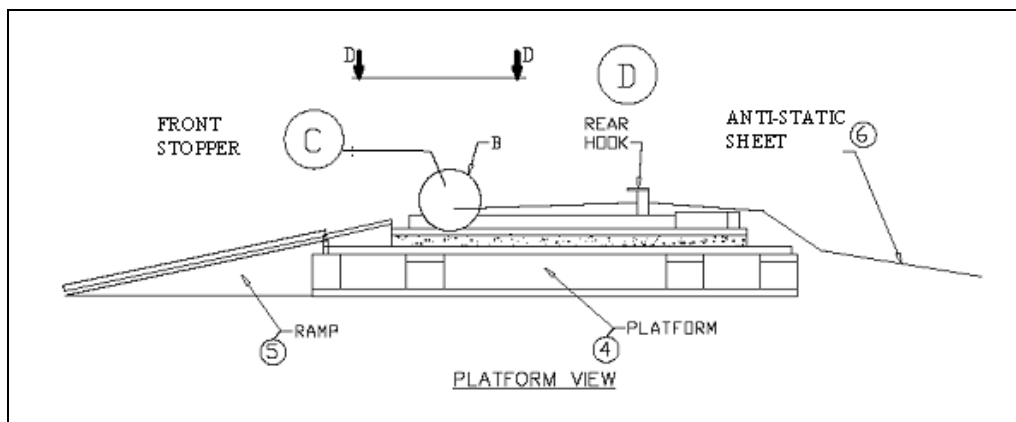

Figure 3-7 Platform View of Shipping Carton

- 5) Remove the small boxes containing the accessories, probes and peripherals from the shipping carton.
- 6) Clear away the carton cover (item 12) from the wooden platform on which the ultrasound unit is standing.
- 7) Cut and remove the antistatic sheet (item 6 in [Figure 3-7](#), above) that is wrapped around the ultrasound unit, taking care not to damage the antistatic cover (item 11 in [Figure 3-8](#) below) covering the unit. Remove the antistatic cover.

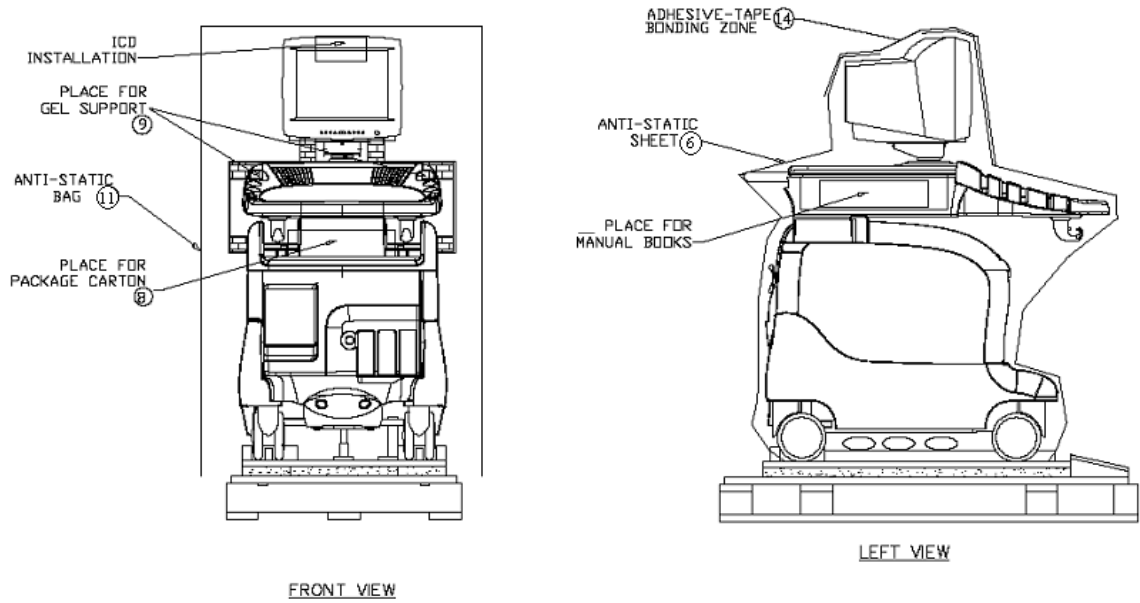

Figure 3-8 Front and Side View of the Unit in the Shipping Carton

- 8) Pull out and remove the monitor support (item 10 in Figure 3-9 below) from under the base of the monitor.

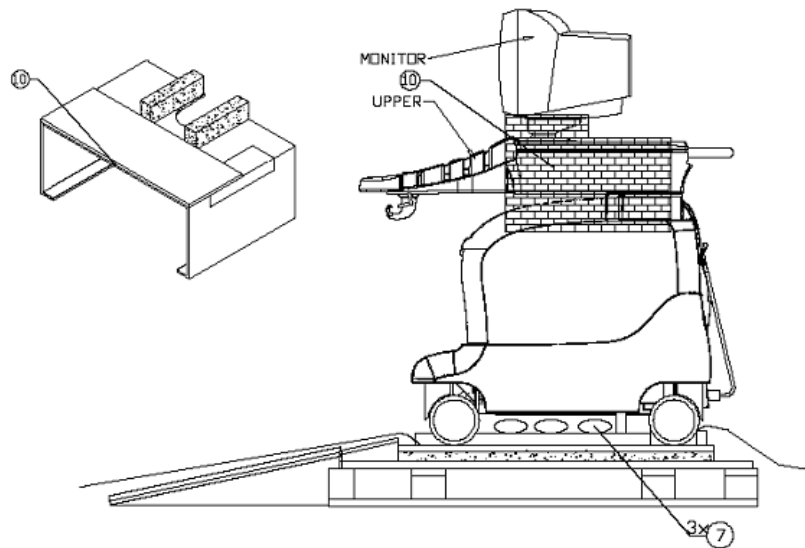

Figure 3-9 Unit in Shipping Carton - Right View

- 9) Release the front stopper (item C in [Figure 3-10](#) below) by sliding the metal sleeve located at the locking pin's base upwards, and then turning it towards you.

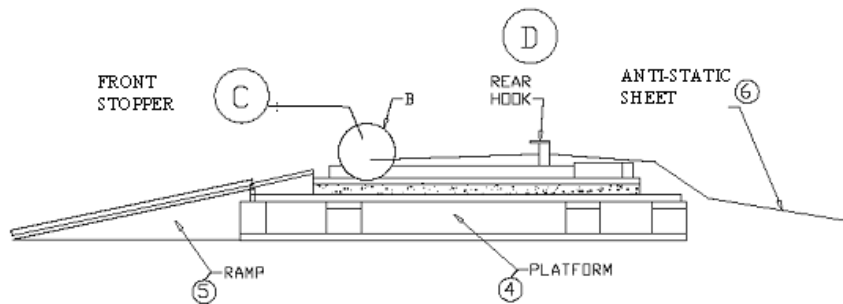

Figure 3-10 Front Stopper Location

- 10) Remove the three silica gel (moisture absorbing) bags (item 7 in [Figure 3-10](#), above) located underneath the ultrasound unit.
- 11) Raise the control console (monitor) by pressing the release grip located under the unit's front handle and remove the two cartons (item 8 in [Figure 3-8](#) on page 3-11) from underneath the control console. These cartons contain the external cables and accessories.
- 12) Lower the control console to its lowest position.
- 13) Remove the manuals (item 4 in [Figure 3-8](#) on page 3-11) from the compartment on the left side of the ultrasound unit.
- 14) Press the brake pedal, located near the bottom of the front of the unit, to the right, to prevent the wheels from swiveling, as described in the *Swivel Brake Label* section, page 1-24.
- 15) Carefully pull the unit backwards from the platform base onto the ramp and roll it down to the floor.
- 16) Press the brake pedal, located near the bottom of the front of the unit, to the left, to lock the wheels, as described in the *Parking Label* section, page 1-24.
- 17) Verify the contents of the shipping carton, as described in [Verifying the Shipping Crate Contents](#) on page 3 - 13.

Section 3-4 Preparing for Installation

3-4-1 Confirming Customer Order

When preparing for installation of a Vivid™ 3 system, it is important to verify that all items ordered by the customer have been received. Compare all items listed on the packing slip (shipping consignment note) with those received and report any items that are missing, back-ordered, or damaged, to your GE Medical Systems sales representative.

3-4-2 Verifying the Shipping Crate Contents

The following sections list the contents of the shipping crate (or shipping carton). Ensure that all components are present before completing the installation.

3-4-2-1 External Cables

The ECG cable (item number 10 or 11) is supplied according to installation location.

Table 3-4 Vivid™ 3 External Cables

Item Number	P/N	Description	Quantity
1	2269430	PWR. CORD, MALE/FEMALE, 10A/(@%)V, 0.60M (PERIPHERALS)	1
2	2266746	AUDIO IN EXT. CABLE	1
3	2266745	AUDIO OUT EXT. CABLE	1
4	2266744	VIDEO OUT EXT. CABLE	1
5	2266743	VIDEO IN EXT. CBL.	1
6	2266742	RS232,D25 TO D9 CBL.	1
7	2253080	B/W PRINT TRIGGER CABLE	1
8	2253079	B/W VIDEO CABLE.	1
9	2300857	PRINTER POWER CABLE	1
10	2256477	ECG CABLES FOR AMERICAS & Japan	
	2269979	5 LEAD ECG CABLE L=3.6M	1
	2269982	LEAD WIRE, GRABBER, 1.3M, WHITE	1
	2269982-2	LEAD WIRE, GRABBER, 1.3M, GREEN	1
	2269982-3	LEAD WIRE, GRABBER, 1.3M, BLACK	1
11	2256478	ECG CABLES FOR EUROPE AND ALL OTHER COUNTRIES	
	2269980	5 LEAD ECG CBL.L=6.3M	1
	2269983	LEAD WIRE, GRABBER,1.3M, YELLOW	1
	2269983-2	LEAD WIRE, GRABBER,1.3M, BLACK	1
	2269983-3	LEAD WIRE, GRABBER,1.3M, RED	1

3-4-2-2 Accessories

Table 3-5 Vivid™ 3 Accessories

Item Number	P/N	Description	Quantity
1	2378183	CD WITH SW V3.2 VIVID3 SYSTEM	1
2	2277423	DISKETTE 3.5" 1.44MB	1
3	066E0007	FOOTSWITCH	1
4	E11821AE	ULTRASOUND GEL BOTTLE	1
5	2277190	MO DISKETTE 2.3GB (OPTIONAL)	1

3-4-3 Component Inspection

After verifying that all the required parts are included in the shipping crate, inspect the system components using the checklist supplied below. In addition, ensure that all the labels described in *Chapter 1 - Introduction* are present, accurate and in good condition, and enter the serial number printed on the main label into the system installation details card, as described in *System Installation Details* on page 3-76.

3-4-3-1 Damage Inspection Checklist

Visually inspect the contents of the shipping crate/shipping carton for damage. If any parts are damaged or missing, contact an authorized GE Service Representative.

A *Damage Inspection Checklist* is provided in [Table 3-6 on page 3-15](#).

Table 3-6 Damage Inspection Checklist

✓	Step	Item	Recommended Procedure
	1	Console	Verify that the system is switched OFF and unplugged. Clean the console and control panel.
	2	Probe Holders	Clean the gel wells with warm water and a damp cloth to remove all traces of gel.
	3	Control Panel	Physically inspect the control panel for missing or damaged items. Verify the proper illumination of all the control panel buttons.
	4	Probes	Check all probes for wear and tear on the lens, cable, and connector. Look for bent or damaged pins on the connector and in the connector socket on the unit. Verify that the EMI fingers around the probe connector socket housing are intact. Check the probe locking mechanism and probe switch.
	5	Monitor	Clean the CRT with a soft cloth dampened with water. Repeat using only water, and wipe with a dry cloth. Inspect the monitor for scratches and raster burn.
	6	Fans	Verify that the FE crate cooling fans, BE fan and peripheral fans are operating and clean.
	7	BE Rear Panel	Check the BE rear panel connectors for bent pins, loose connections and loose or missing hardware. Screw all the cable connectors tightly to the connector sockets on the panel. Verify that the labeling is in good condition.
	8	Covers	Check that all screws are in place, all chassis and internal covers are installed and that the air filters are in place.
	9	Peripherals	Check and clean the peripherals in accordance with the manufacturer's directions. To prevent EMI or system overheating, dress the peripheral cables inside the peripheral cover.
	10	AC System	Check the AC board connectors and the associated cabling for good connection and proper insulation. Verify that the connections are secured.
	11	Power Cord	Check the power cord for cuts, loose hardware, tire marks, exposed insulation, or any deterioration. Verify continuity. Tighten the clamps that secure the power cord to the unit and the outlet plug to the cord. Replace the power cord and/or clamp, as required.
	12	Front Castors	Check that the front castors can swivel, and can be placed in swivel lock and full lock by the foot brake pedal.
	13	Rear Castors	Check that the rear castors can roll and swivel but cannot lock.

3-4-3-2 Front and Side View of the Vivid™ 3 Ultrasound Unit

Figure 3-11 below shows the Vivid™ 3 ultrasound unit components that are visible from the *front* and *side* of the ultrasound unit.

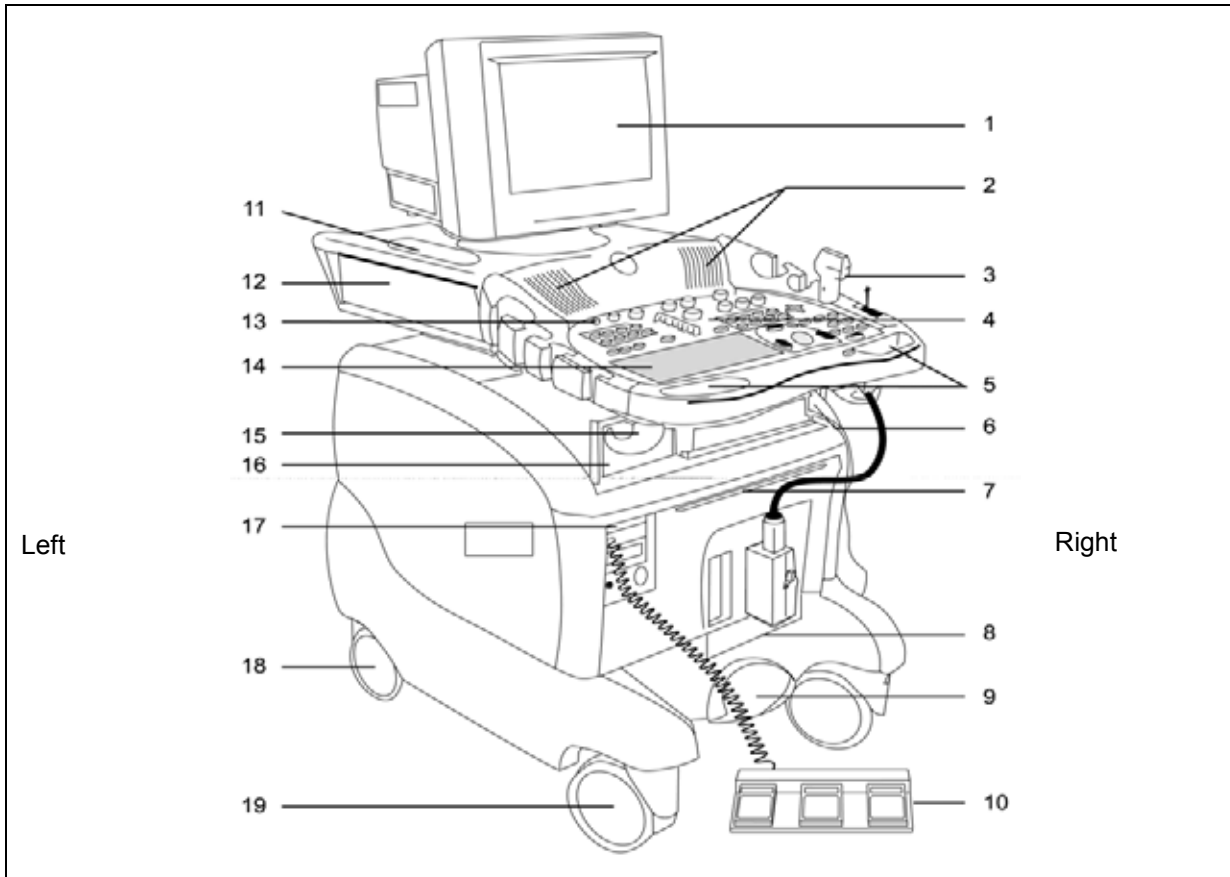

Figure 3-11 Front and Side View of the Vivid™ 3

- 1 Display Monitor: Swivels to the left and right, and tilts up and down.
- 2 Speakers: Two loudspeakers for Doppler sound.
- 3 Probe Holders and Probes: Situated on either side of the front panel.
- 4 Control Panel: Contains the alphanumeric keyboard and the buttons used to operate the ultrasound unit.
- 5 Front Handle.
- 6 Raise/Lower the Control Console Up/Down Handle: Located midway underneath the front handle. Used to raise or lower the control console (control panel and monitor).
- 7 Air Filter: Located above the crate.
- 8 Probe Ports:
 - Three active probe connectors (one for a pencil probe), and a fourth, inactive port on the right side of the unit, which is used for parking.
 - Four active probe connectors (one for a pencil probe).



- 9** Foot Brake: Three-position brake, as follows:
 - LEFT (P) locks the wheels.
 - MIDDLE unlocks the wheels.
 - RIGHT (double arrows) locks the swivel action.
- 10** Footswitch: Configurable footswitch connected to the patient I/O module that enables keyboard commands to be operated by foot.
- 11** Gel Holders: Situated on either side of the control console, and on the top surface on either side of the monitor.
- 12** Optional storage compartment.
- 13** On/Off Switch.
- 14** Alphanumeric Keyboard and Operation Buttons.
- 15** Cable Hook.
- 16** Peripherals: The VCR recorder and/or black-and-white printer and/or color printer are positioned on the peripheral storage area of the control console.
- 17** CD Read/Write (CDRW) and MO Disk (optional).
- 18** Rear Castors.
- 19** Front Castors.

3-4-3-3 Rear View of the Vivid™ 3 Ultrasound Unit

The following figure shows the Vivid™ 3 ultrasound unit components that are visible from the *rear* of the ultrasound unit:

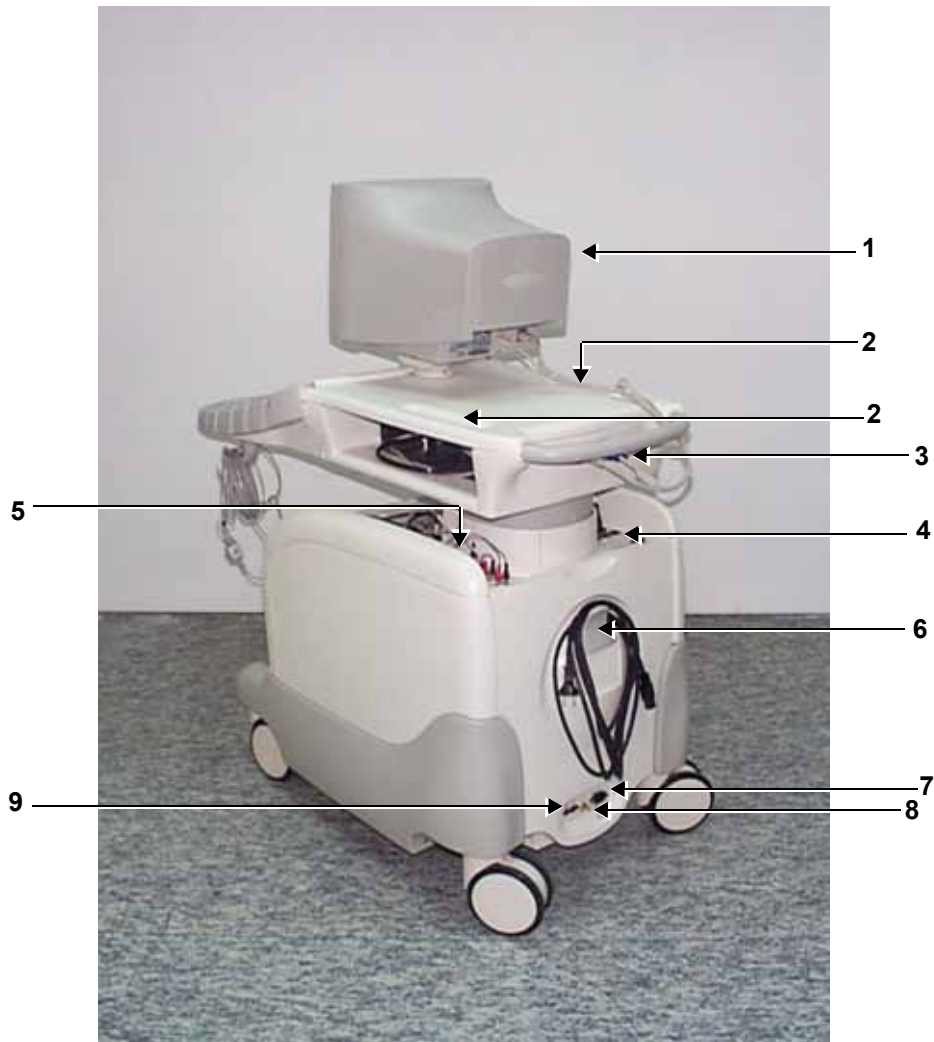

Figure 3-12 Rear View of the Vivid™ 3

- 1 Monitor
- 2 Gel Wells
- 3 Monitor Connection Panel
- 4 Left Rear Panel
- 5 Right Rear Panel
- 6 Power Cable Storage Hook
- 7 Circuit Breaker On/Off Switch
- 8 Ground Screw
- 9 Power Cable Socket

3-4-4 System Voltage Confirmation

3-4-4-1 System Voltage Settings

Verify that the scanner is set to the correct voltage.

The Voltage settings for the Vivid™ 3 Scanner are found on a label to the right of the Power switch and External I/O, on the rear of the system.



Figure 3-13 Rating Plate Example



WARNING: CONNECTING A VIVID™ 3 SCANNER TO THE WRONG VOLTAGE LEVEL WILL MOST LIKELY DESTROY THE SCANNER.

3-4-4-2 Confirming System Voltage Configuration

- 1) Turn ON the system.
- 2) In regular 2D Scanning Mode, press **Config**.
- 3) From the System Configuration dialog box, click the **Technical Support** tab.
- 4.) Make sure the frequency and voltage ranges are set up correctly and that the appropriate settings are displayed in the *Power Supply Frequency* and *Nominal Voltage* fields (lower right side of the dialog box - see [Figure 3-28](#) on page 3-47).
- 5) Click **OK**.

Note: If the voltage is not set correctly, contact an authorized GE Service Representative.

3-4-5 Video Formats Confirmation

The Vivid™ 3 ultrasound scanner and VIC may be configured to operate with either PAL or NTSC video systems, as required.

3-4-5-1 Video Format Confirmation

- 1) Turn ON the system and the check video transmission signal is set correctly.
- 2) Press **Config**.
- 3) From the System Configuration dialog box, select the **VCR/ECG** tab and make sure Either **PAL** or **NTSC** is selected.
- 4) Click the **Technical Support** tab and make sure Frequency is set to either **60Hz** for NTSC, or **50Hz** for PAL.
- 5) Click **OK**.

Note: If the video format is not set correctly, contact an authorized GE Service Representative.

3-4-6 Ensuring Protection from EMI

The Vivid™ 3 unit has been designed to minimize the effects of Electro-Magnetic Interference (EMI). Many of the covers, shields, and screws are provided primarily to protect the system from image artifacts caused by this interference. For this reason, it is imperative that all covers and hardware are installed and secured before the unit is put into operation.

Ensure that the system is protected from electromagnetic interference (EMI), as follows:

- Operate the system at least 15 feet away from equipment that emits strong electromagnetic radiation.
- Operate the system in an area enclosed by walls, floors and ceilings comprised of wood, plaster or concrete, which help prevent EMI.
- Shield the system when operating it in the vicinity of radio broadcast equipment, if necessary.
- Do not operate mobile phones or other EMI emitting devices in the ultrasound room.
- Verify that all EMI rules listed in the following table are followed:

Note: The Vivid™ 3 ultrasound unit is approved for use in hospitals, clinics and other environmentally qualified facilities, in terms of the prevention of radio wave interference. Operation of the ultrasound unit in an inappropriate environment can cause electronic interference to radios and television sets situated near the medical equipment.

Table 3-7 EMI Prevention/ Abatement

EMI Rule	Details
Ground the unit.	Poor grounding is the most likely reason an ultrasound unit will have noisy images. Check the grounding of the power cord and power outlet.
Be aware of RF sources.	Keep the unit at least 5m (16.4 ft) away from other EMI sources. Special shielding may be required to eliminate interference problems caused by high frequency, high powered radio or video broadcast signals.
Replace and/or reassemble all screws, RF gaskets, covers and cores.	After you finish repairing or updating the system, replace all covers and tighten all screws. Any cable with an external connection requires a magnet wrap at each end. Install the shield over the front of the card cage. Loose or missing covers or RF gaskets allow radio frequencies to interfere with the ultrasound signals.
Replace broken RF gaskets.	If more than 20% or a pair of the fingers on an RF gasket are broken, replace the gasket. Do not turn on the unit until any loose metallic part is removed and replaced if needed.
Do not place labels where RF gaskets touch metal.	Never place a label where RF gaskets meet the unit. Otherwise, the gap created will permit RF leakage. In case a label has been found in such a location, move the label to a different appropriate location.
Use GE specified harnesses and peripherals.	The interconnect cables are grounded and require ferrite beads and other shielding. Cable length, material, and routing are all important; do not make any changes that do not meet all specifications.
Take care with cellular phones.	Cellular phones may transmit a 5 V/m signal that causes image artifacts.
Properly address peripheral cables.	Do not allow cables to lie across the top of the card cage or hang out of the peripheral bays. Loop any peripheral cable excess length inside the peripheral bays or hang on the hooks provided below the console. Attach the monitor cables to the frame.

Section 3-5 Completing the Hardware Installation

It is recommended to pay attention to the system specifications and make sure the facility has been prepared in accordance with the information provided in *Chapter 2 - Pre-Installation*.

For easy reference, the physical specifications of the Vivid™ 3 ultrasound unit are shown in [Table 3-8](#) below.

Table 3-8 Vivid™ 3 - Physical Specifications

Measurement	Metric Specifications	Imperial Specifications
Height (with monitor)	131 — 145 cm	51.6 — 57.1 in
Width	62.5 cm	25 in
Depth	112 cm (100 cm without rear handle)	44 in (40 in without rear handle)
Weight	160 kg	353lbs

When moving the system, always adhere to the following the precautions:



CAUTION: At least two people must be available to deliver and unpack the Vivid™ 3 ultrasound unit. Attempts to move the unit considerable distances (or on an incline) by one person alone, could result in personal injury, and/or damage to the system.



CAUTION: The Vivid™ 3 weighs 160 kg (353 lbs) or more - depending on installed peripherals - when ready for use. Care must be used when moving it or replacing its parts. Failure to follow the precautions listed could result in injury, uncontrolled motion and costly damage.

ALWAYS:

Be sure the pathway is clear.

Use slow, careful motions.

Use two people when moving the system on inclines or lifting more than 16 kg (35 lbs).

3-5-1 Connecting the Footswitch

- 1) Connect the triple footswitch to the **Footswitch** input on the left side of the front panel, as shown in [Figure 3-8](#) on page 3-11.
- 2) After connecting the peripherals and switching the system on, configure the footswitch, as described in *System Tab* on page 3-36.

3-5-2 Connecting Peripherals

Peripheral devices, such as a VCR or printer, are connected to the Vivid™ 3 ultrasound unit using the rear panel connectors. Ensure that all peripheral devices connected to the ultrasound unit comply with national safety requirements for medical equipment, including IEC601, CSA22.2, AS3200.1 and UL544.

The Vivid™ 3 ultrasound unit can operate with one or more of the following types of on-board peripherals:

- VCR
- Black & White (B/W) Printer
- Color Printer
- Deskjet Color Printer HP6122

Note: Each of the peripherals have European and US versions. For a complete list of recommended peripherals, refer to the *Vivid™ 3 Pro/Vivid™ 3 Expert User Manual*. For information for each peripheral device, refer to the manufacturer's manual.

On-board peripherals must be connected to one of the two available auxiliary power supplies on the right rear panel. The total load on both auxiliary AC outlets should not exceed 500 VA. This means 8 Amp @ 100-120V AC or 4 Amp @ 220-240V AC.

Voltages are set according to local country voltage, as described in the *Voltage Level Checks* section, on page 3-31.

For more details about peripherals installation refer to *Vivid™ 3 Peripherals Installation Manual*.

3-5-2-1 Rear Panel Connectors

The Vivid™ 3 ultrasound unit is equipped with two rear panels that provide the connections for peripheral devices, as shown in [Figure 3-14](#) below.

Note: Right and left are determined from the front of the unit. Refer to the *Right Rear Panel Connectors* section, on page 3-24, and to the *Left Rear Panel Connectors* section, on page 3-25, for details about each panel.

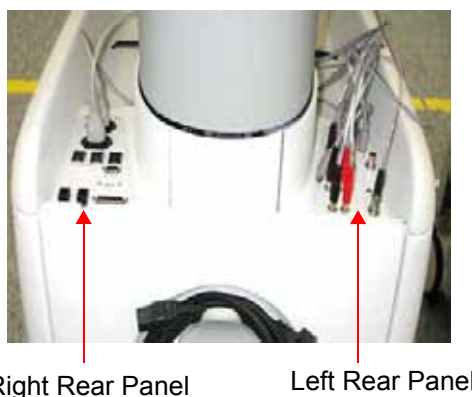

Figure 3-14 Rear Panel Connectors Rear View

3-5-2-1-1 Right Rear Panel Connectors

Table 3-9 describes the connectors included in the right rear panel (shown in Figure 3-15):

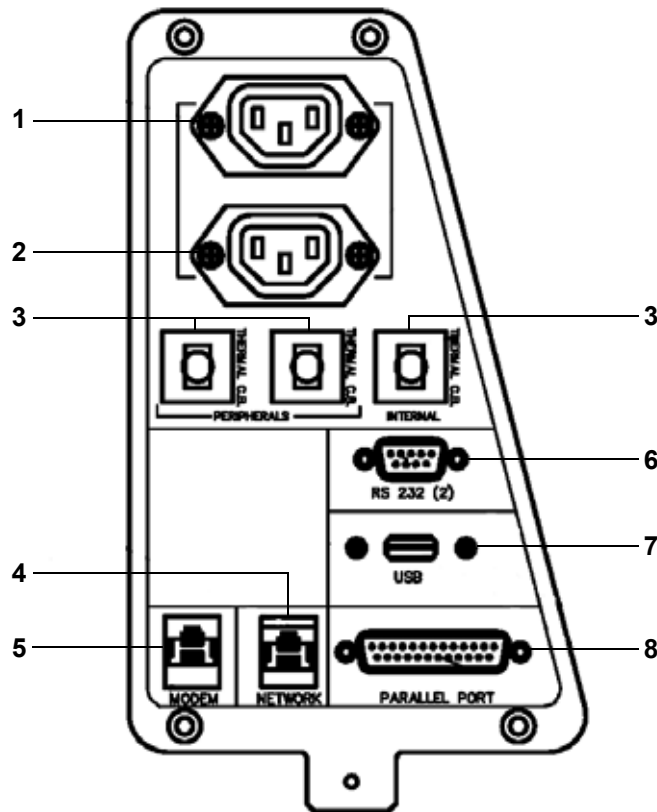

Figure 3-15 Right Rear Panel Connectors

Table 3-9 Right Rear Panel Connectors

Name	Description
1. AUXILIARY AC OUTLET	For use with external peripherals. Voltages are set according to local country voltage.
2. AUXILIARY AC OUTLET	For use with external peripherals. Voltages are set according to local country voltage. If additional auxiliary outlets are required, use the special cable provided by GE. DO NOT attempt to connect additional peripherals using an external wall outlet.
3. THERMAL CIRCUIT BREAKERS	Three 4A thermal circuit breakers for fuse protection.
4. NETWORK	For the network connection.
5. MODEM	For use with the service platform (iLinq).
6. RS 232 (2)	Not in use.
7. USB	For GE Service usage only (not for external USB devices).
8. PARALLEL PORT	25 pin connector for use with the external peripherals.

3-5-2-1-2 Left Rear Panel Connectors

Table 3-10 describes the connectors included in the left rear panel (shown in Figure 3-16):

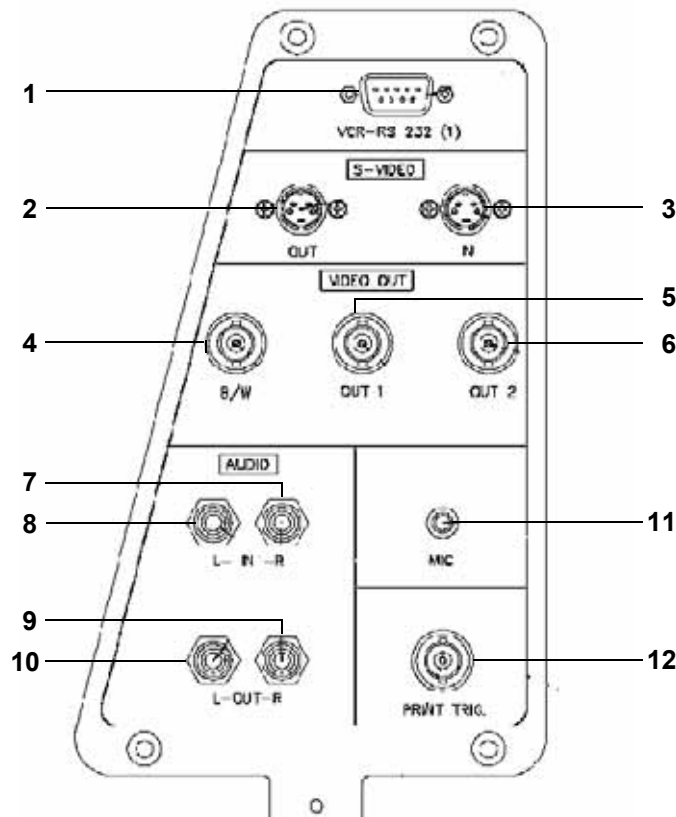

Figure 3-16 Left Rear Panel Connectors

Table 3-10 Left Rear Panel Connectors

Name	Description
1. VCR-RS 232 (1)	One standard 9-pin RS232 (1) connector for VCR control (COM 1).
2. S-VIDEO OUT	Y/C Video Out: 4 pin connector for output to an S-VHS VCR.
3. S-VIDEO IN	Y/C Video In: 4 pin connector for input from an S-VHS VCR.
4. VIDEO OUT B/W	BNC connector for composite B/W video output to a hard copy printer.
5. VIDEO OUT 1	BNC connector for composite color video output (PAL or NTSC).
6. VIDEO OUT 2	BNC connector for composite color video output (PAL or NTSC).
7. AUDIO IN (RIGHT)	RCA jack.
8. AUDIO IN (LEFT)	RCA jack.
9. AUDIO OUT (RIGHT)	RCA jack.
10. AUDIO OUT (LEFT)	RCA jack.
11. MIC	Microphone input.
12. PRINT TRIG.	BNC connector for the exposure control of a multi-imager or another peripheral activated by pressing Print B .

3-5-2-2 Connecting the VCR

- 1) Place the VCR on the peripheral tray and connect the following:

Table 3-11 VCR Cables

From the VCR	To the Left Panel	DIP on VCR Right Panel
S-Video IN	S-Video OUT (Y/C OUT)	1-4 OFF (down)
S-Video OUT	S-Video IN (Y/C OUT)	5-6 ON (up)
Audio IN	Audio OUT	
Audio OUT	Audio IN	
BE Control (RS-232)	VCR RS 232 (1)	

- 2) Install the VCR according to the VCR installation schematics, see [Figure 8-159](#) on page 8-161.
- 3) After connecting the remaining peripherals and switching the system on, configure the VCR settings, as described in the *VCR/ECG Tab* section, on page 3-45.

For more details about peripherals installation refer to the *Vivid™ 3 Peripherals Installation Manual*.

3-5-2-3 Connecting the Black & White Printer

- 1) Place the printer on the peripheral tray and connect the following cables as shown in [Table 3-12](#).

Table 3-12 Black & White Printer Cables

From the Printer	To the Left Panel
Video IN	Composite Video OUT B/W
External Trigger	Print Trigger
Power Cable	Right Connectors Panel AC outlet

- 2) Install the printer according to the printer's installation schematics, see [Figure 8-110](#) on page -126.
- 3) After connecting the remaining peripherals and switching the system on, configure the printer settings, as described in the *Printers Tab* section, on page 3-43.

For more details about peripherals installation refer to the *Vivid™ 3 Peripherals Installation Manual*.

3-5-2-4 Connecting the Color Printer

- 1) Place the color printer in the printer compartment above the B/W printer and VCR on the peripheral tray, using an additional shelf.
- 2) Connect the following cables as shown in [Table 3-13](#):

Table 3-13 Color Printer Cables

From the Color Printer	To the Cables underneath the Control Console
Video IN	Composite/Video OUT 1
External Trigger	Print Trigger
AC IN	AC Power Cable

Note: All the color printer cables are located in the left storage compartment under the metal cover.

- 3) After connecting the remaining peripherals and switching the system ON, configure the printer settings, as described in the *Printers Tab* section, on page 3-43.

For more details about peripherals installation, refer to the *Vivid™ 3 Peripherals Installation Manual*.

3-5-2-5 Connecting the DeskJet Color Printer HP6122

Note: If there is sufficient space, the DeskJet Color Printer may be installed under the control console. Alternatively, it will require a suitable stand or table to be positioned in close proximity to the Vivid™ 3 scanner - at a distance of *not more than* 1m (3.3 ft) from the power connection to the Vivid™ 3 unit.



WARNING: Whenever moving the Vivid™ 3 scanner, the DeskJet Color Printer must be disconnected from the scanner. DO NOT attempt to move the two units simultaneously without first disconnecting them. After relocation, re-connect the printer to the scanner.

- 1) Place the DeskJet color printer on the shelf below the control console (or alternatively on the designated stand or table, adjacent to the unit).
- 2) Connect the following cables as shown in [Table 3-14](#):

Table 3-14 DeskJet Color Printer Cables

From the Color Printer	To the Right Panel
Parallel Port Connector	Parallel Port
AC IN (AC Dual Power cable)	Panel AC outlet

- 3) After connecting the remaining peripherals and switching the system ON, configure the printer settings, as described in the *Printers Tab* section, on page 3-43.

For more details about peripherals installation refer to the *Vivid™ 3 Peripherals Installation Manual*.

3-5-3 Connecting Probes

The Vivid™ 3 ultrasound unit operates with various types of probes that are used for scanning patients, including flat phased, convex and linear electronic array probes. Once connected, the probes can be selected for different applications.

Probe connectors on the unit's control panel are as follows:

- Three active probe connectors (one for a pencil probe), and a fourth, inactive port on the right side of the unit, which is used for parking.

OR

- Four active probe connectors (one for a pencil probe).

Probes can be connected or changed any time, as described below:

- 1) Inspect the probe socket to verify that it is free of debris.
- 2) Hold the rectangular probe connector vertically so that the probe's cable points upwards.
- 3) Rotate the probe locking latch *counterclockwise* to the unlock (horizontal) position.
- 4) Gently insert the connector into one of the matching sockets on the front of the unit. Gently push the connector in as far as possible.
- 5) Rotate the locking latch 90 degrees *clockwise* to lock the connector into place (vertical).

NOTE: *It is not necessary to turn OFF power to connect or disconnect a probe.*

3-5-3-1 Available Probes

The following probes are available for use with the Vivid™ 3 ultrasound unit:

Table 3-15 Available Probes

P/N	Description
2232337	3S SECTOR (new design)
2259135	7L (546L)
2259145	10L (739L) LINEAR
2259153	C358 PROBE (OUTSIDE JAPAN)
2259206	I739L LINEAR
2295377	12L
2263669	7S SECTOR
2266328	10S
2169773	P509 (Japan)
2259246	T739L LINEAR
KN100011	5T TEE MULTIPLANE
KN100022	6T (Super TEE)
KN100023	8T (Ped TEE)
KN100072	9T(PED TEE) (for RFI systems only)
KZ200476	5S SECTOR
TE100024	Pencil P2D
TQ100002	Pencil P6D
KZ200476	Adaptor PAMPTE/6Tv
2301954	E721
KQ100006	i8L
KW100011	i13L

3-5-4 Connecting the ECG

The internal ECG is connected into a rectangular-shaped socket on the patient trace (I/O) panel. The patient trace (I/O) panel is located on the front of the ultrasound unit, as shown in [Figure 3-11](#) on page 3-16. Each socket is clearly labelled and color coded, as shown in [Figure 3-17](#) below.

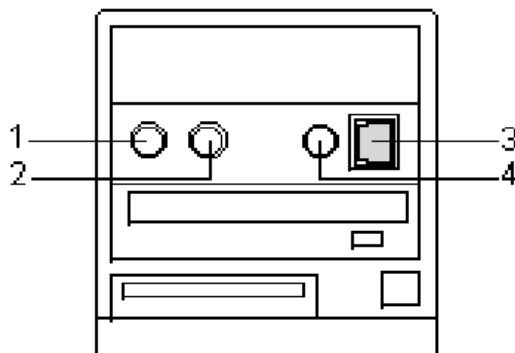
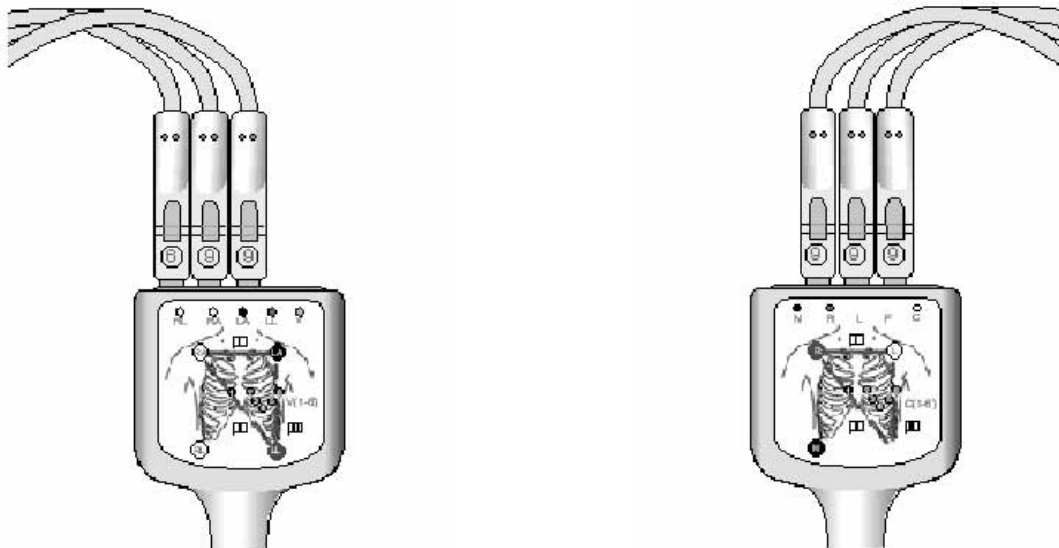

Figure 3-17 Connection Sockets for ECG Cables

- 1 Footswitch (black)
- 2 Phono (blue)
- 3 ECG (green)
- 4 External ECG (yellow)

The ECG cable is a modular cable consisting of four different cable parts. The main part (trunk) is a single cable connecting to the unit at one end, and providing a cable splitter device at the other end. The splitter contains five receptacles, only three of which are used with the Vivid™ 3 Pro/Vivid™ 3 Expert ultrasound unit.

Three color coded electrode cables are inserted into the splitter in the appropriate color-coded receptacles. Each electrode cable hooks up to the appropriate stick-on electrode by a clip-type connector. The color coding of the electrodes follows one of two standards that are common in different parts of the world. The cable splitter has a drawing defining the color codes, names and electrode placements for each of the three cables, as shown in [Figure 3-18](#) on page 3-30.



AHA (Americas, Japan)

IEC (Europe, Asia, ROW)

Figure 3-18 ECG Cable and Electrode Placement

Note: For optimal ECG operation, use only electrodes that meet universal standards - see [Table 3-16](#).

Table 3-16 ECG Cable Types

Description		Part No.
Full ECG Cable Kit - AHA (Americas, Japan)		2256477
	Black wire (LA)	2269982-3
	White wire (RA)	2269982
	Green wire (RL)	2269982-2
Full ECG Cable Kit - IEC (Europe, Asia, ROW)		2256478
	Yellow wire (L)	2269983
	Red wire (R)	2269983-3
	Black wire (N)	2269983-2

3-5-5 Connecting the Unit to a Power Source

The initial connection of the Vivid™ 3 ultrasound unit to a power source should be performed by a qualified person, authorized by GE Medical Systems. Use only the power cords, cables and plugs provided by or designated by GE Medical Systems to connect the unit to the power source.



CAUTION: Verify compliance with all electrical and safety requirements and check the power cord to verify that it is intact and of hospital-grade before connecting the unit to the power source. Products equipped with a power source (wall outlet) plug should be connected to the fixed power socket that has a protective grounding conductor. Never use an adapter or converter to connect with a power source plug (for example, a three-prong to two-prong converter).

3-5-5-1 Voltage Level Checks

The following voltage level checks are required:

- 1) Check the rating label at the rear of the ultrasound unit, as described in *Chapter 1 - Introduction*, and verify that your local AC Voltage corresponds to the voltage setting as indicated on the rating label. The rating label indicates that the factory preset input AC voltage is one of the following:
 - 100 V
 - 120 V
 - 220 - 240 V
- 2) Verify the maximum power requirement as follows:
 - Maximum power = 1.2 KVa (the system might need)
 - 100 V 60-50 Hz 8A
 - 120 V 60-50 Hz 8A
 - 220 - 240 V 60-50 Hz 4A



DANGER: Failure to provide an adequate earth circuit (Ground) may cause electrical shock and serious injury.

3-5-5-2 Connecting the Ultrasound Unit to the Electrical Outlet

Note: To help assure grounding reliability, connect to a hospital-grade or “hospital only” grounded power outlet. If using the ultrasound unit with an external UPS system, follow all the grounding and applicable safety standards as documented both in this manual and the external UPS manufacturer’s manual. The external UPS system is to be considered the AC outlet.

- 1) Verify that the AC wall outlet is of the appropriate type.
- 2) Turn off the AC circuit breaker at the rear of the unit.
- 3) Plug the power cord connector into the AC input socket, and secure it in place using the attached clip - see [Figure 3-19](#)

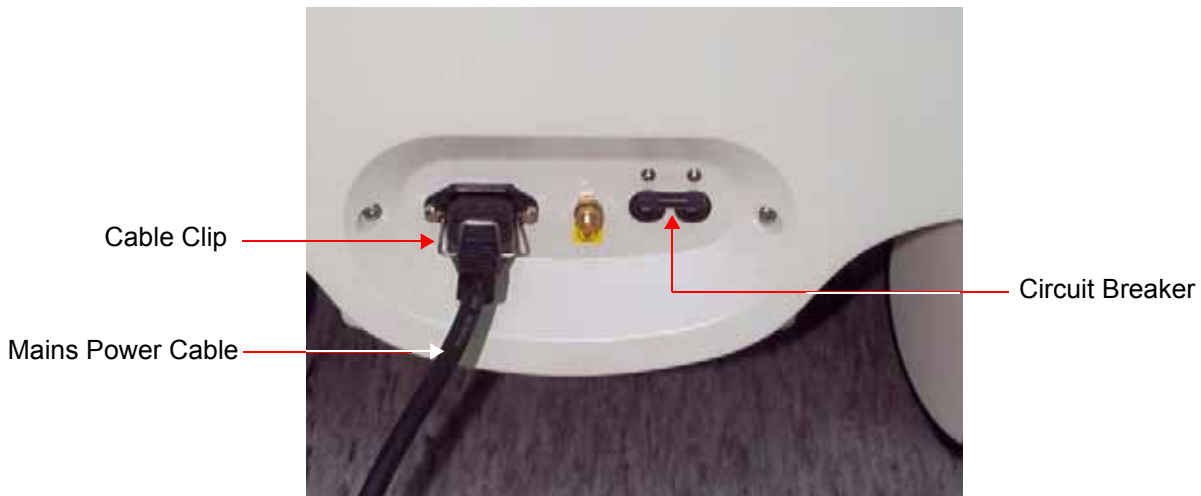

Figure 3-19 Circuit Breaker and Power Cable on Back of Scanner

- 4) Plug the other end of the power cord to the AC wall outlet. Allow sufficient slack so that the plug will not be pulled out if the unit is slightly moved. The remaining length of the cord should be looped and hung on the hook provided.



DANGER: To avoid the risk of fire, power to the system must be supplied from a separate, properly rated outlet. It is recommended to use a dedicated power outlet. The power plug should not, under any circumstances, be altered to a configuration rated less than that specified for the current. **DO NOT** use an extension cord or adaptor plug. Refer to the *Electrical Requirements* section, on page 2-3 for more details.

3-5-5-3 Disconnecting the Ultrasound Unit from the Electrical Outlet



CAUTION: Whenever disconnecting the Vivid™ 3 unit from the electrical outlet, always observe the safety precautions. First unplug the mains power cable from the wall outlet socket, then from the unit itself. Remove by pulling on the cable connector - DO NOT pull on the cable.

- 1) Turn OFF the AC circuit breaker on the rear of the unit.
- 2) Unplug the mains power cable from the AC wall outlet socket.
- 3) Unplug the mains power cable connector from the AC input socket (refer to [Figure 3-19](#) on page 3-32).

NOTICE Disconnecting the Mains Power Cable *before* switching OFF the Circuit Breaker will activate the uninterruptible power system (UPS) in the back-end processor, forcing an ordered shutdown of the system.

3-5-6 Switching the System ON/OFF

3-5-6-1 Switching the System ON

- 1) Verify that the ultrasound unit has been connected to the power supply and that the circuit breaker is ON, as described in the *Connecting the Ultrasound Unit to the Electrical Outlet* section, on page 3-32.

NOTICE When AC power is applied to the scanner, the **On/Off** button on the control console illuminates amber, indicating the Back-end Processor is in *Standby* mode.

- 2) Hold down the **On/Off** button on the control panel for 3 seconds. The system automatically performs an initialization sequence which includes the following:
 - Loading the operating system.
 - Running a quick diagnostic check of the system.
 - Detecting connected probes.

The system first enters 2D-Mode with the probe and application that were last used before the system was shut down. If the probe has been removed since the system was last used, the currently connected probes and their available applications are displayed and selected by default.

3-5-6-2 Switching the System OFF

NOTE: *After turning OFF the system, wait at least 10 seconds before turning it on again. The system may not be able to boot-up if power is recycled too quickly.*

The system can be switched OFF in one of three ways:

- By holding down the **On/Off** button for 3 seconds, the unit will perform an automatic shutdown sequence that protects the hard disk and switches into an energy-saving standby mode.
- By holding down the **On/Off** button for more than 3 seconds, the unit will display a shutdown menu, enabling the operator to shutdown the system to standby mode or to perform a full shutdown (see [Figure 3-20](#) on page 3-34).
- By holding down the **On/Off** button for more than 10 seconds, the unit will perform an emergency shutdown. It is not recommended to use this type of shutdown unless the application is locked and no other operation can be performed.

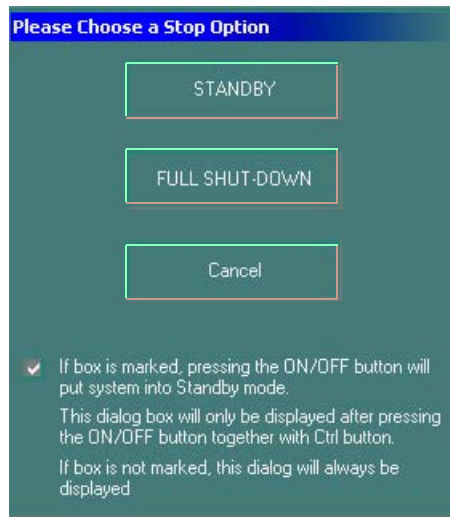

Figure 3-20 Shut-Down Options Screen

Section 3-6 System Configuration

Once all the required peripherals have been installed and the unit has been switched on, configure the system settings in the *System Configuration* window tabs. Refer to the Vivid™ 3 Pro/Vivid™ 3 Expert User Manual for additional information about system configuration.

3-6-1 Adjusting the Display Monitor

The display monitor's contrast and brightness controls may need periodic adjustment due to changes in ambient light. They can be adjusted using the **Contrast** and **Brightness** buttons on the front part of the display monitor.

All display monitor controls, other than the contrast and brightness controls, are factory adjusted for optimum settings and usually do not require further adjustment.

For details on adjusting the display monitor settings, refer to the *Monitor Operation* section, on page 6-9.

3-6-2 Hospital Info Tab

- 1) Press **Config** on the alphanumeric keyboard. The *System Configuration* window is displayed with the **Hospital Info** tab selected, as shown below:

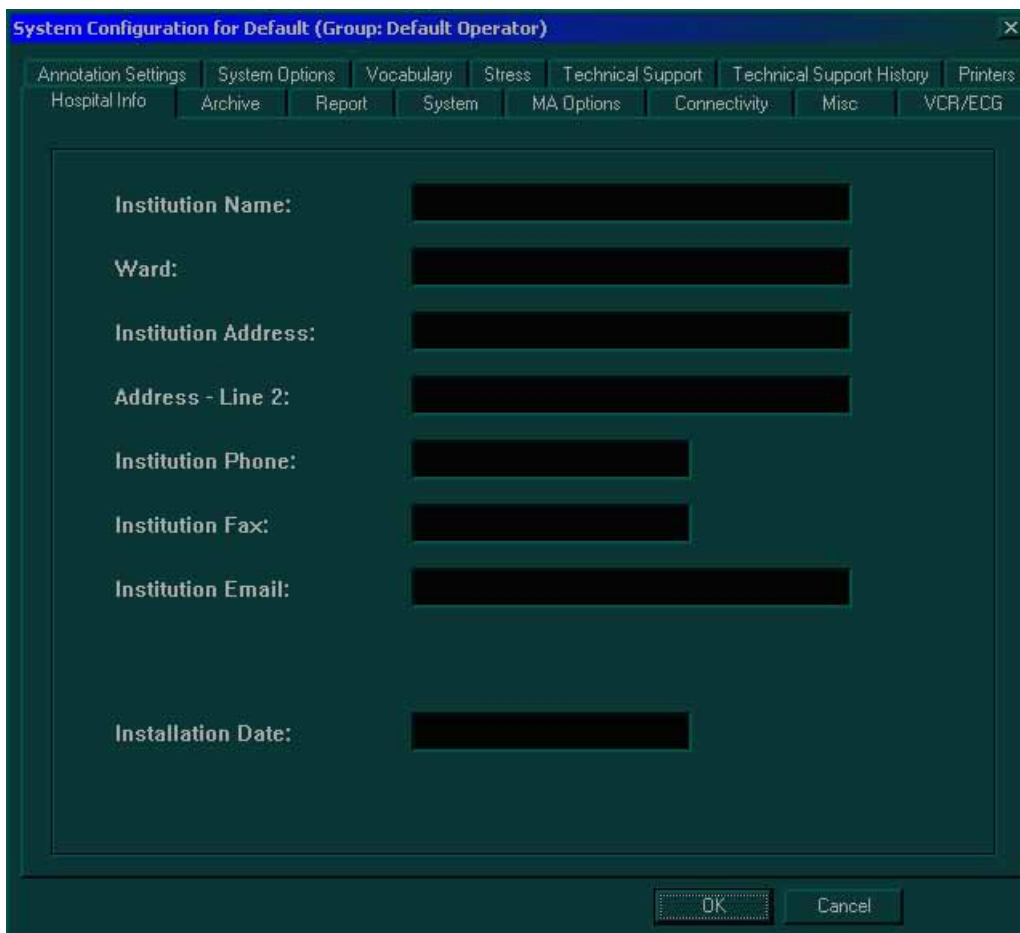

Figure 3-21 Hospital Info Tab

- 2) In the **Hospital Info** tab, enter the required information in the appropriate fields.
- 3) Trackball to the **OK** button and press **Select**.

3-6-3 System Tab

- 1) Press **Config** on the alphanumeric keyboard. The *System Configuration* window is displayed.
- 2) Trackball to the **System** tab and press **Select**. The software information is displayed in the upper portion of the tab, as shown below:

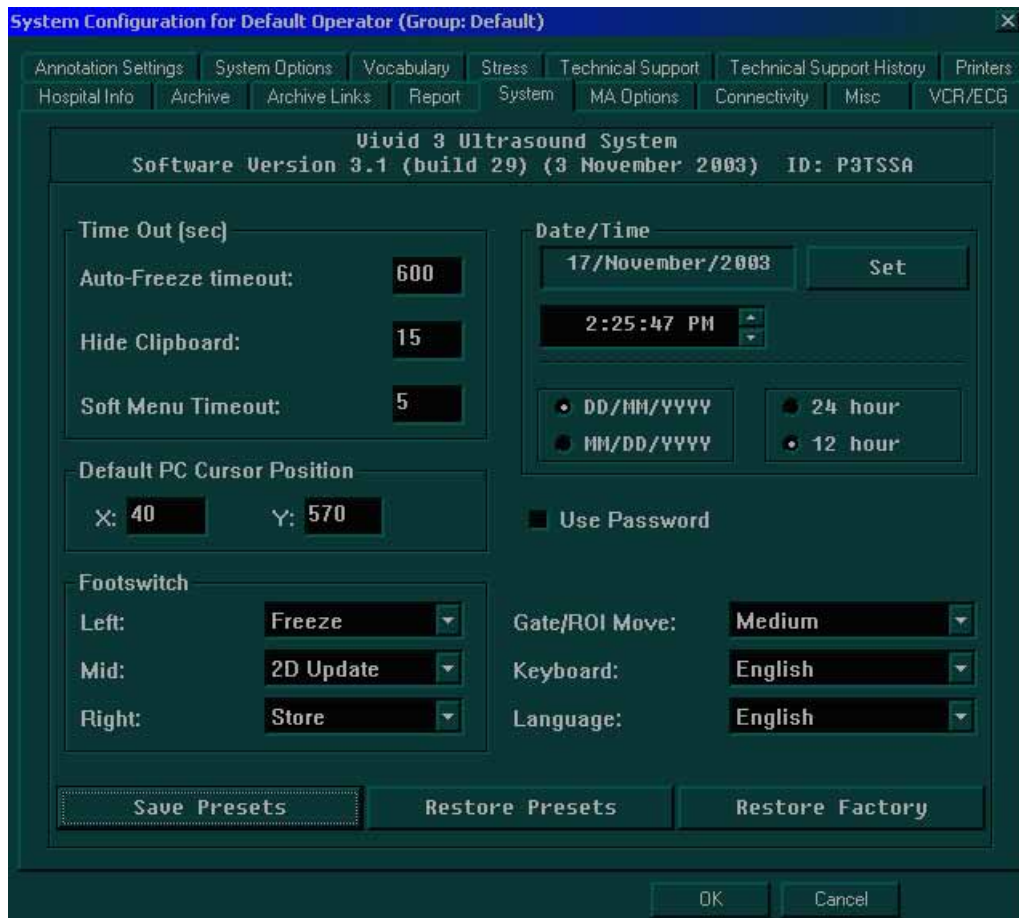

Figure 3-22 System Tab

Note: To avoid corruption of the archives, do not change the date.

- 3) In the **STANDBY timeout** field of the **Time Out (sec)** area, enter the amount of time (in seconds) after which the system switches to standby mode when it is not being used.
- 4) In the **Date/Time** area, set the date and time, as follows:
 - Trackball to the **Set** button and press **Select**. Use the alphanumeric keyboard to select the current date.
 - Select the format of the date and time display, for example, DD/MM/YYYY.
 - Select the hour mode, for example, 24 hour or 12 hour.
 - In the **Default PC Cursor Position** area, specify the default location of the PC cursor on the screen by entering the X and Y coordinates into the **X** and **Y** fields. The [Figure 3-22](#), above indicates the recommended default factory setup for X and Y.
- 5) In the **Footswitch** area, define the functions that will be performed when each of the three pedals on the footswitch is used by selecting the relevant function from the **Left**, **Mid** and **Right** drop-down lists.
- 6) Select the system language from the **Language** dropdown list.
- 7) Trackball to the **OK** button and press **Select**.

3-6-4 Connectivity Tab

For details on the **Connectivity** tab, refer to the *Connectivity Setup* section, on page 3-50.

3-6-5 Archive Tab

- 1) Press **Config** on the alphanumeric keyboard. The *System Configuration* window is displayed.
- 2) Trackball to the **Archive** tab and press **Select**. The **Archive** tab is displayed, as shown below:

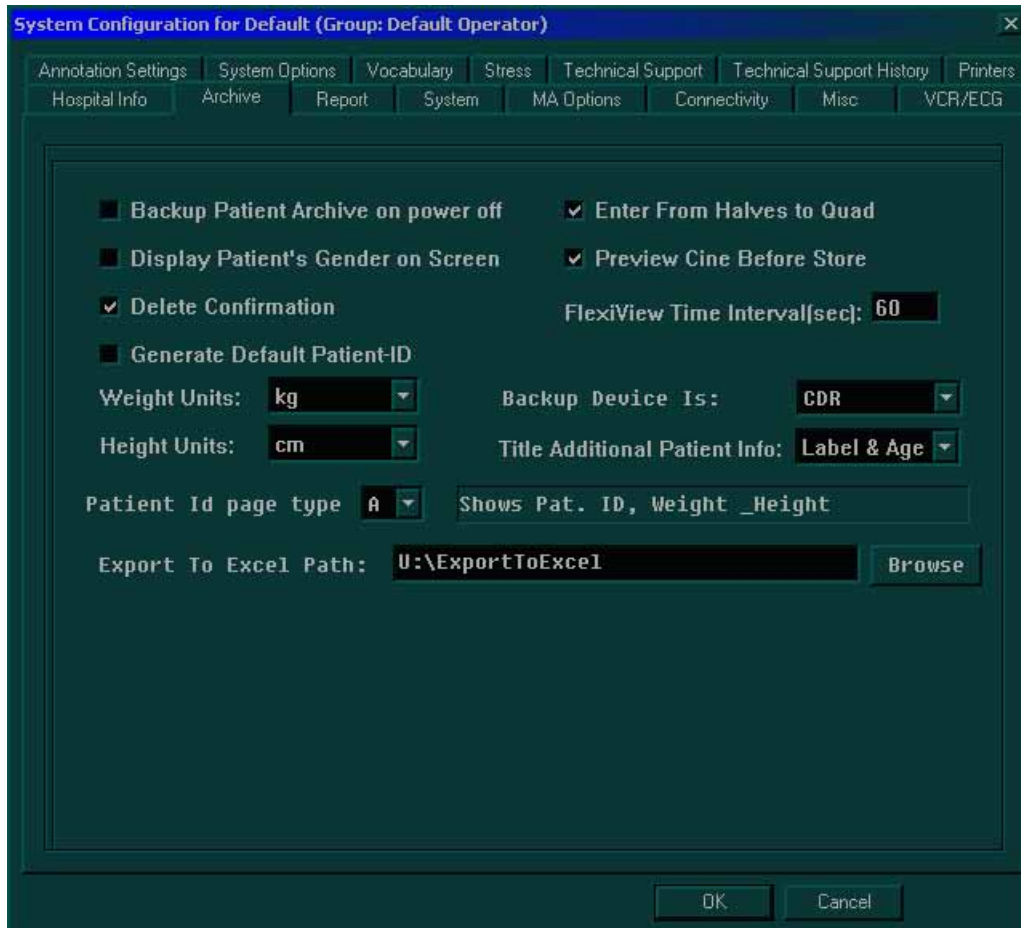

Figure 3-23 Archive Tab

Note: The **Archive** tab will display even if the Archive Package option is not installed.

- 3) Select **Display patients gender on screen** to display the patient's gender in the patient information area of the scanning screen (not applicable to OB applications).
- 4) Select **Delete Confirmation** to prompt the user to confirm delete commands.
- 5) Select the type of weight measurement to be used during examinations and in the *Patient Details* pages from the **Weight Units** dropdown list.
- 6) Select the type of height measurement to be used during examinations and in the *Patient Details* pages from the **Height Units** dropdown list.

- 7) Select the patient ID page type from the **Patient ID Page Type** dropdown list, as follows:
 - **Type A:** displays patient ID, last and first name, weight, height, BSA, BP and other fields.
 - **Type B:** displays all Type A fields except patient ID.
 - **Type C:** displays all Type A fields except patient ID, weight, height and BSA. It also displays the sonographer's name.
 - **Type D:** displays all Type A fields except patient ID, weight, height, BSA and BP.
- 8) Select the patient data to be displayed in the patient information area of the scanning screen title bar from the **Title Additional Patient Info** dropdown list.
- 9) Select the type of media, to which data is stored during backup, from the **Backup Device Is** dropdown list.
- 10) Select **Eject MO Disk on Shutdown** to have the system automatically eject the backup media when the unit is shut down.
- 11) Enter the location of ASCII files in the user (U:\path\) partition of the internal hard disk in the **Export To Excel Path** field.
- 12) Select **Enter From Halves to Quad** to enable the user to toggle between viewing a single image, two images or four images on the screen simultaneously (Quad View).
- 13) Select **Preview Cine Before Store** to display cineloops before they are stored.
 - When the FlexiView option is installed the time period (in seconds) after which a cineloop is automatically stored in the archive without interrupting the user's monitoring must be set in the **FlexiView Time Interval[sec]** field. [Figure 3-23](#) on page 3-37 indicates the recommended default factory setup.
- 14) Trackball to the **OK** button and press **Select**.

3-6-6 Annotation Settings Tab

- 1) Press **Config** on the alphanumeric keyboard. The *System Configuration* window is displayed.
- 2) Trackball to the **Annotation Settings** tab and press **Select**. The **Annotation Settings** tab is displayed, as shown below:

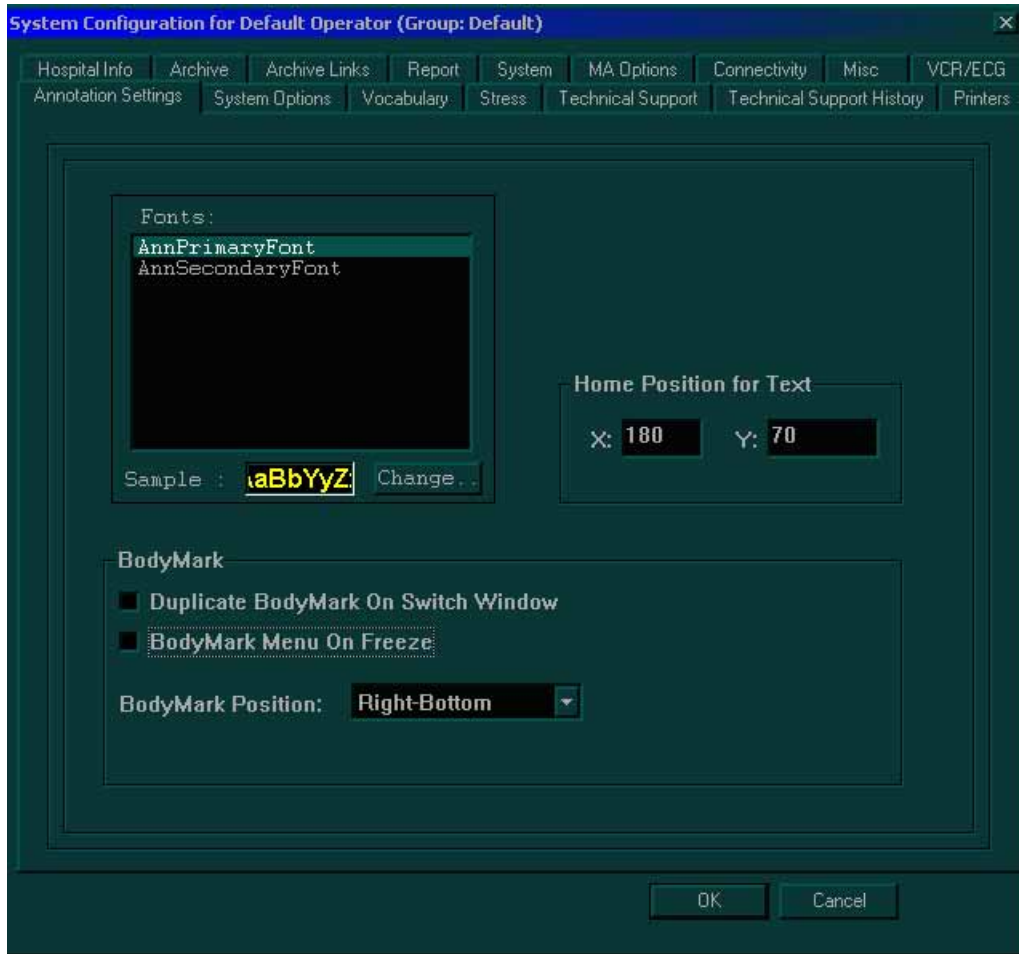

Figure 3-24 Annotation Settings Tab

- 3) Define the primary and secondary fonts to be used for annotations, as follows:
 - Trackball to the font to be defined (**Primary** or **Secondary**) in the **Fonts** area and press **Select**. The font name is highlighted.
 - Trackball to the **Change** button and press **Select**. The *Font* dialog box is displayed.
 - Trackball to the required font, color, style and size and press **Select** for each choice.
 - Trackball to **OK** and press **Select**. The font is defined.
 - In the **Home position for text** area, set the home position for the text cursor, by entering the X and Y coordinates into the **X** and **Y** fields, as required.

Note: After setting the font type for the annotations the user can change the font type during annotation typing by pressing on the **Menu** key and selecting the required font from the drop-down list. Thereafter, additional typing will be in the newly-modified font.

- 4) Select the required Bodymark position from the available selections (*Left-bottom; Left-top; Right top; Right bottom*).

Whenever the Bodymark is now displayed, it will appear in the newly-selected position (until such time as this setting is changed)

- 5.) Activate the *Duplicate Bodymark on Switch Window* and/or the *Bodymark Menu on Freeze* checkboxes, as required.

Note: For more details on using the Bodymark features, refer to the *Vivid™ 3 User Manual*.

- 6) Trackball to the **OK** button and press **Select**.

3-6-7 System Options Tab

- 1) Press **Config** on the alphanumeric keyboard. The *System Configuration* window is displayed.
- 2) Trackball to the **System Options** tab and press **Select**. The **System Options** tab is displayed, as shown below:

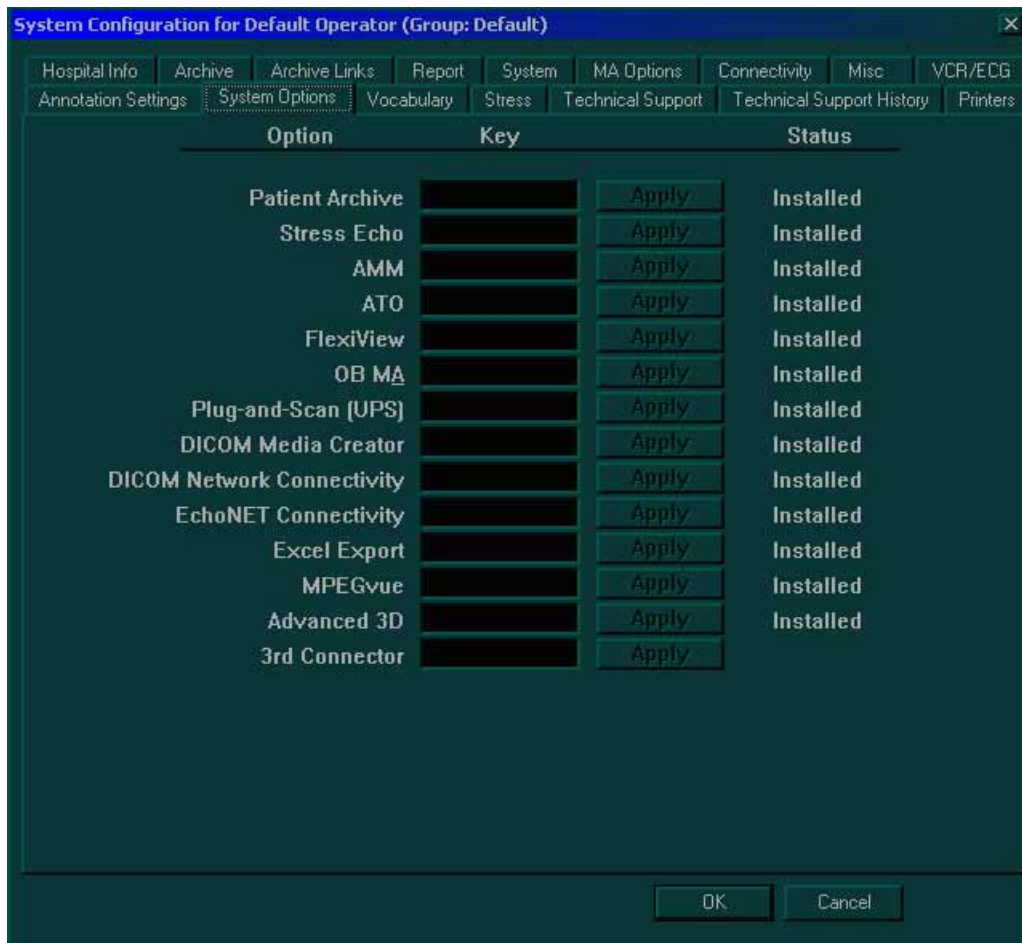

Figure 3-25 System Options Tab

Note: If an option is not available for the specific ultrasound unit, the option name and **Key** field is disabled (grey).

- 3) Trackball to the **Key** field next to the name of the option being installed, and use the alphanumeric keyboard to enter the password supplied by GE.

Note: If an incorrect password is entered, if the option has already been correctly installed in the system, it will be removed.

Note: Please note that all passwords should be visible underneath the control console or/and on the green password (option) certificate. If a new password (option) is required, contact the GE representative to initiate the appropriate process, so that the relevant password (option) will be installed on the system.

- 4) Trackball to **Apply** and press **Select**. The status of the option changes to **Installed**.
- 5) Repeat steps 3 and 4 as required.
- 6) Trackball to the **OK** button and press **Select**.

Note: If an option was not initially purchased or installed, it may be acquired and/or installed later. During option installation, type the relevant password in the appropriate Option window (see [Figure 3-25](#)) and click **Apply**. The **Installed** status (to the right of the Apply button) will then be visible.

3-6-8 Printers Tab

- 1) Press **Config** on the alphanumeric keyboard. The *System Configuration* window is displayed.
- 2) Trackball to the **Printers** tab and press **Select**. The **Printers** tab is displayed, as shown below:

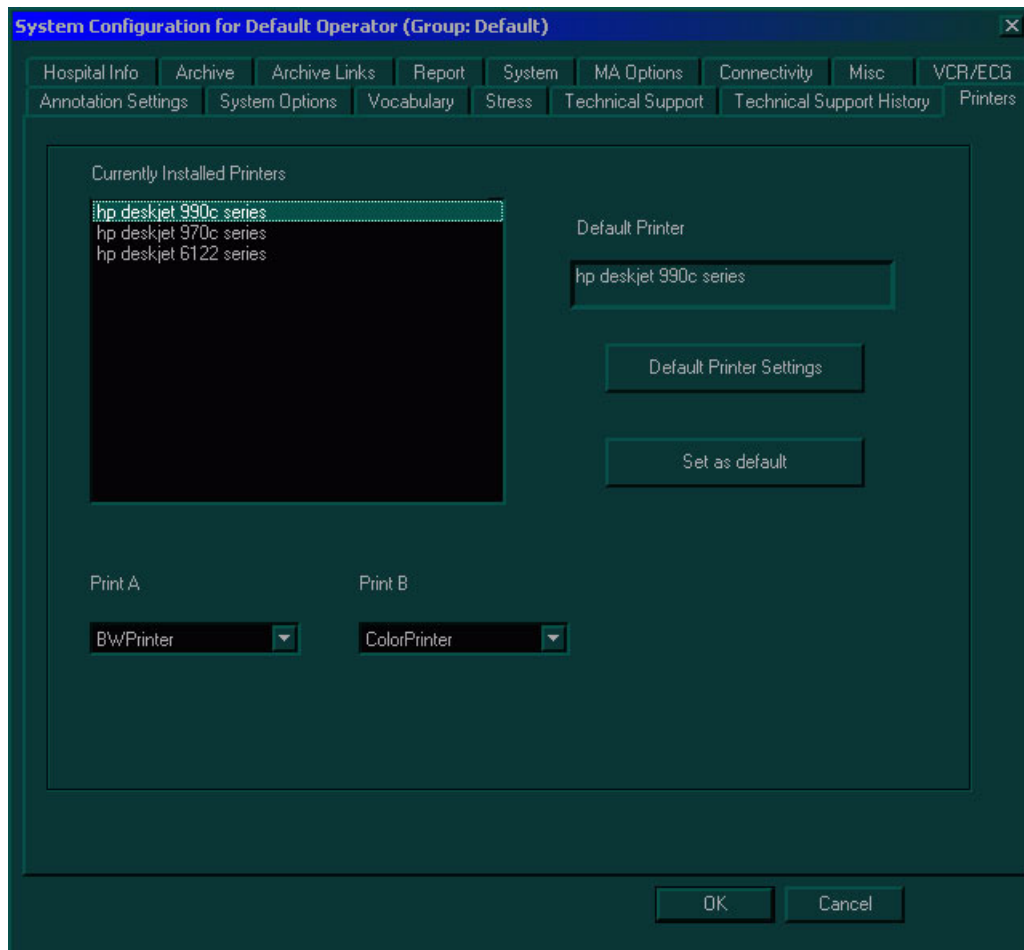

Figure 3-26 Printers Tab

Note: Please note, the printers indicated in the *Currently Installed Printers* field, are the recommended and approved printers to be used with the Vivid™ 3 system. Other generic printers are not approved, and GE Medical Systems will not guarantee their correct operation on this system.

- 3) In the **Currently Installed Printers** area, trackball to the required printer and press **Select**. The printer is highlighted.
- 4) Trackball to the **Set as default** button and press **Select**. The selected printer is set as the default printer and is shown in the text box above the option buttons.

Note: If required, two printers may be configured for use with the system (for example, one color, one black & white), by selecting the required options under each of two drop-down lists (labelled *Print A* and *Print B*, respectively) as shown in the following steps:

- 5) TRACKBALL to the **Print A** combo box (in the lower left area of the screen) choose the required printer and press **Select**. (In the example below, *BW Printer* is selected).



- 6) Trackball to the **Print B** combo box, choose the required printer and press **Select**.
(In this example, Color Printer is selected).
- 7) Trackball to the **OK** button and press **Select**.

Note: To test that printer configuration is satisfactory, verify that paper has been loaded and that the ink cartridge is installed. Select any report and try to print it, verify that printing quality and information is satisfactory.

3-6-9 VCR/ECG Tab

- 1) Press **Config** on the alphanumeric keyboard. The *System Configuration* window is displayed.
- 2) Trackball to the **VCR/ECG** tab and press **Select**. The **VCR/ECG** tab is displayed, as shown below:

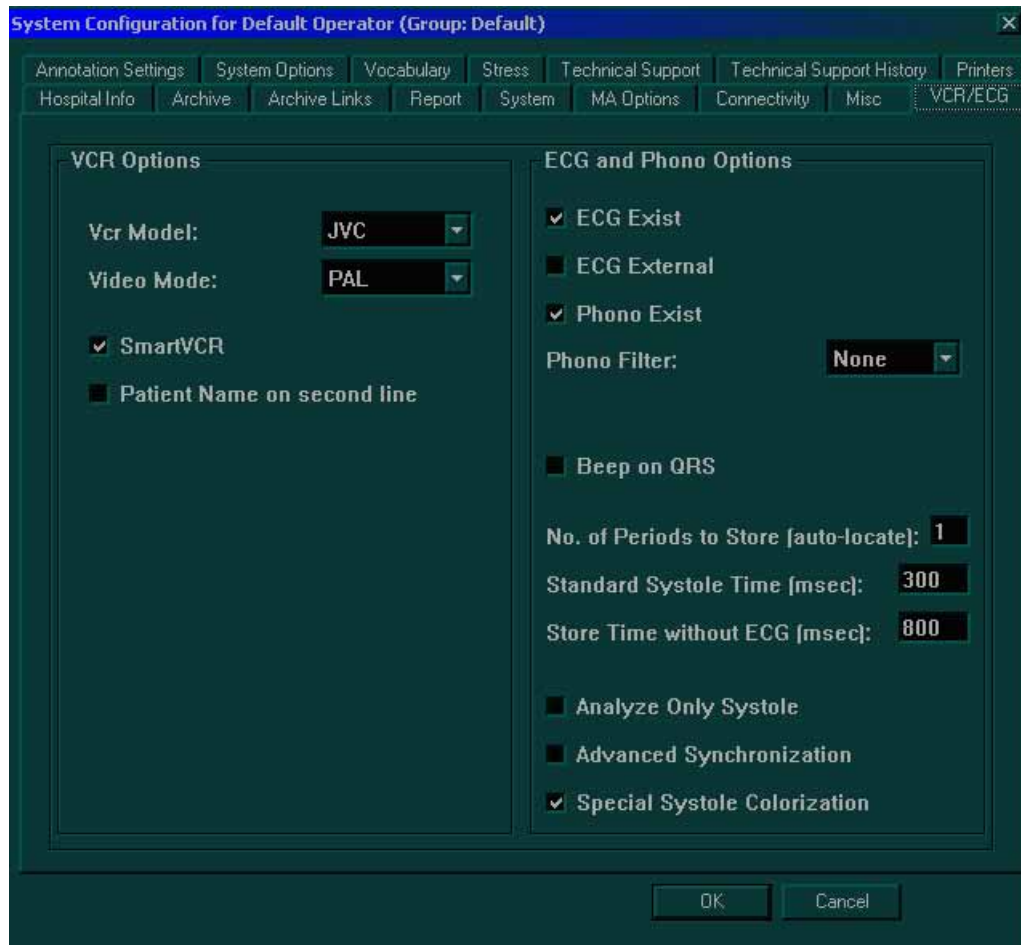

Figure 3-27 VCR/ECG Tab

- 3) In the **VCR Options** area, complete the following, as required:
 - Select the appropriate VCR from the **VCR Model** dropdown list, for example, *Sony*, *JVC*, or *Panasonic*.
 - Select the video system from the **Video Mode** dropdown list, for example, *PAL* or *NTSC*.
 - Select the **SmartVCR** option to enable Measurement and Analysis measurements and calculations on recorded VCR images.
 - Select the **Patient Name on second line** option to display the patient's name on the second line. For use when an external monitor omits picture borders.
- 4) If done, trackball to the **OK** button and press **Select**.

Note: To test the VCR option, insert a video cassette. Refer to the *Peripherals* section, on page 4-4.

- 5) In the **ECG and Phono Options** area, complete the following, as required:
- Select each connected option including, **ECG Exist**, **ECG External**, **Phono Exist** and/or **Phono Filter**.
 - In the **No. of Periods to Store (auto-locate)** field, enter the number of heart cycles (1-4) of the frozen image that will be displayed in the multiple screen/split screen when in freeze mode.
 - In the **Standard Systole Time (msec)** field, enter the default systole time, which enables cineloop synchronization.
 - In the **Store time without ECG (msec)** field, define the default length of a cineloop when there is no ECG trace.
 - Select the **Analyze only Systole** checkbox to place markers only on the systole portion, for synchronization and analysis purposes.
 - Select the **Advanced Synchronization** checkbox to enable the use of a special synchronization algorithm. This algorithm allows non-linear stretching of the time base to compensate for non-linearity of the heart cycle between the resting HR and elevated HR.
 - Select the **Special Systole Colorization** checkbox to enable the function of systole and diastole colorization, if required. This function will present the systolic ECG signal in a different color from that of the diastolic ECG signal.

Note: The default factory setups are seen in [Figure 3-27](#) on page 3-45. However, the user may want to set different values and presets.

3-6-10 Technical Support Tab

The System Configuration *Technical Support* tab is used when new hardware has been installed, or when it necessary to enable new functionality. The appearance of the Technical Support tab differs in accordance with the specific Vivid™ 4 BT03 model (RFI or RFT configuration), as described below.

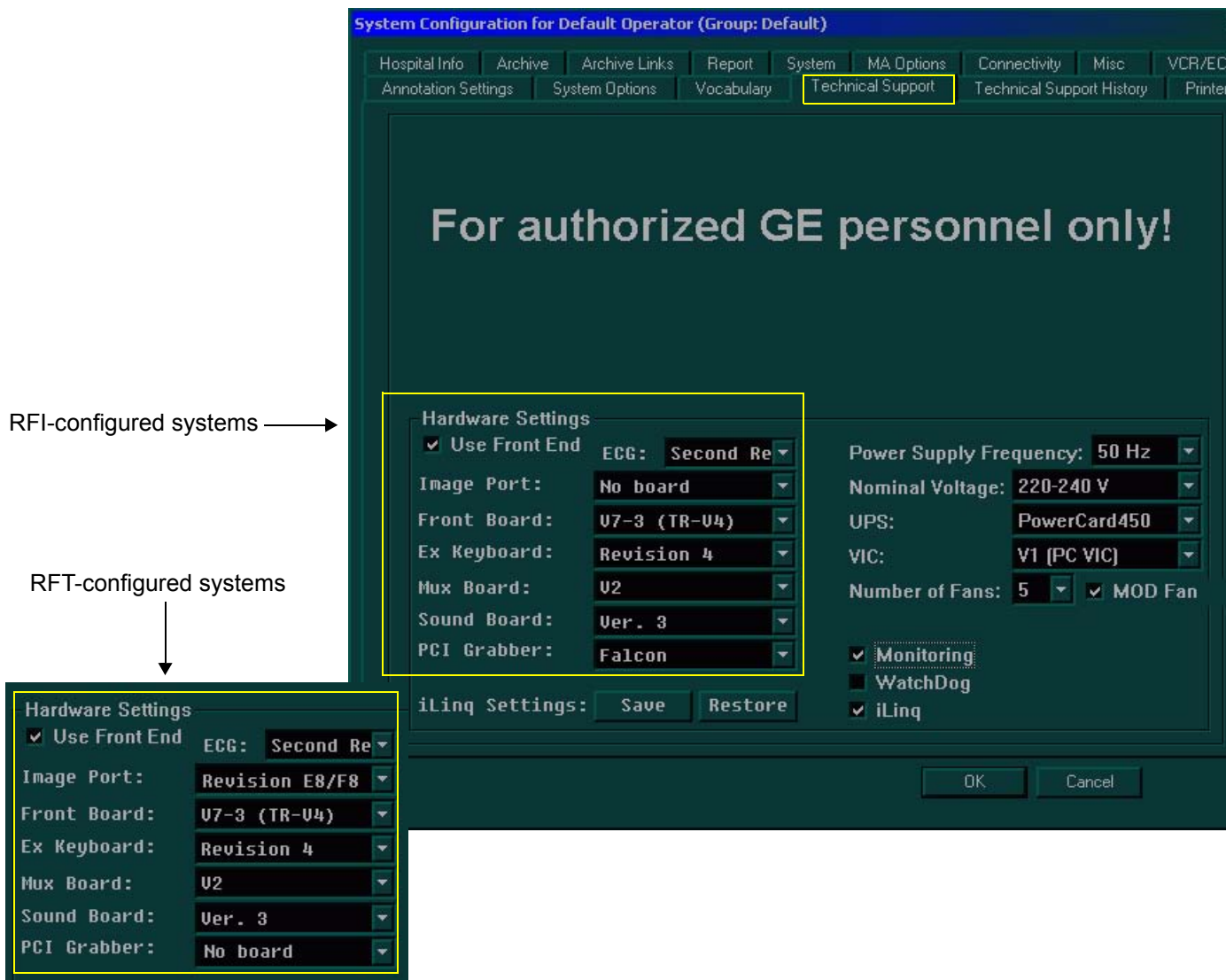

Figure 3-28 Technical Support Tab

- Monitoring** - should *always* be enabled (this provides constant monitoring of critical parameters to ensure safe operation of the system).
- Watchdog** - normally should not be enabled. When enabled, if there is a system lock-up caused by the Back End, this will turn OFF power at the Front End.
- MOD Fan** - should be enabled only on BEPs based on Pentium IV - this provides faster operation of the MOD. Enabling this option in the wrong type of BEP may cause damage to the MOD or MO media.
- Use Front End** - normally should be enabled.
- iLinq** - should be enabled only on systems that use the iLinq option.

Table 3-17 Recommended Vivid™ 3 Hardware Configurations - RFI Models

Item	BT03 Vivid™ 3
ECG	Second Re
Image Port	No board
Front Board	V7-3 (TR-V4) or V7-2 (TR-V4)
Ex Keyboard	Revision 4
MUX Board	V2
Sound Board	Ver. 3
PCI (Frame) Grabber	Falcon
Network Board	Intel EtherExpr
UPS	PowerCard 450
VIC	V1 (PC VIC)
Number of Fans	5

Table 3-18 Recommended Vivid™ 3 Hardware Configurations - RFT Models

Item	BT03 Vivid™ 3	BT03 Pro
ECG	Second Re	Second Re
Image Port	Revision E8/F8	Revision E8/F8
Front Board	V7-3 (TR-V4) or V7-2 (TR-V4)	V7-3 (TR-V4) or V7-2 (TR-V4)
Ex Keyboard	Revision 4	Revision 4
MUX Board	V2	V2
Sound Board	Ver. 3	Ver. 3
PCI (Frame) Grabber	No board	No board
SCSI Board	AHA-29160N	AHA-29160N
Network Board	Intel EtherExpr	Intel EtherExpr
UPS ^a	PowerCard 450	PowerCard 450
VIC	V1 (PC VIC) ^b	V1 (PC VIC) ^b
Number of Fans	5	5

a. optional

b. valid only for Pentium 4; when a machine is based on Pentium III, use V0 (external).

Note: When a system's Back End is upgraded to Pentium 4, in future the BEP should only be replaced with a Pentium 4-type BEP. See *Chapter 8 - Replacement Procedures* and *Chapter 9 - Renewal Parts* for more details.

3-6-11 Technical Support History Tab

The Technical Support History is where you would record any historical technical support information that may be relevant to a problem, or any other maintenance operations performed.

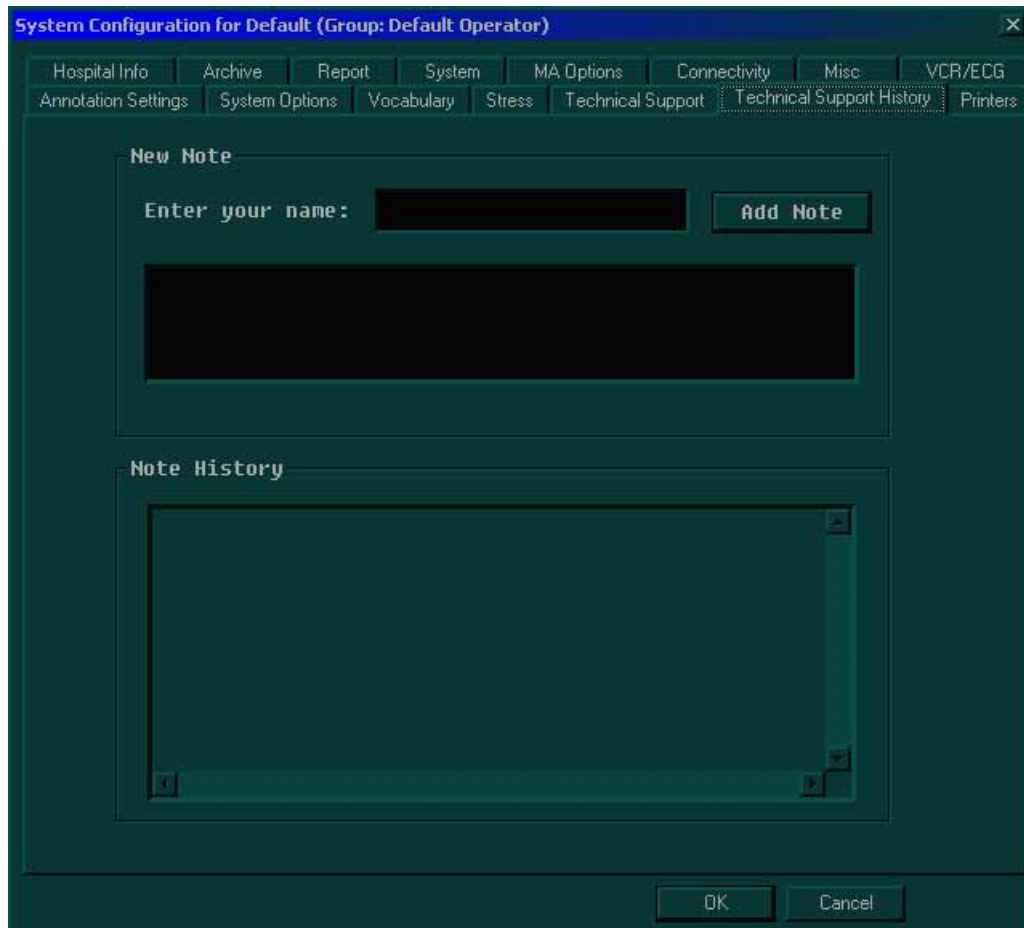

Figure 3-29 Technical Support History Tab

Section 3-7 Connectivity Setup

3-7-1 Introduction

The Vivid™ 3 ultrasound unit can be connected to various connectivity devices, such as DICOM devices and EchoPac servers. The following sections describe how to connect the system to a remote archive/work station or a DICOM service, using a TCP/IP connection.

3-7-2 Physical Connection

3-7-2-1 Ethernet Switch Connections

An Ethernet Switch (P/N: 066E0741), is used to connect the Vivid™ 3 system to an EchoPAC PC and a network printer.



Figure 3-30 Ethernet Switch Identifications

Table 3-19 MDI Button Position Descriptions

Position	Label	Function
	X To PC	To connect an end station or a Server to the Port
	= To HUB	To connect a HUB or another Switch to the Port

3-7-2-2 Local Network Connection to EchoPAC PC Workstation

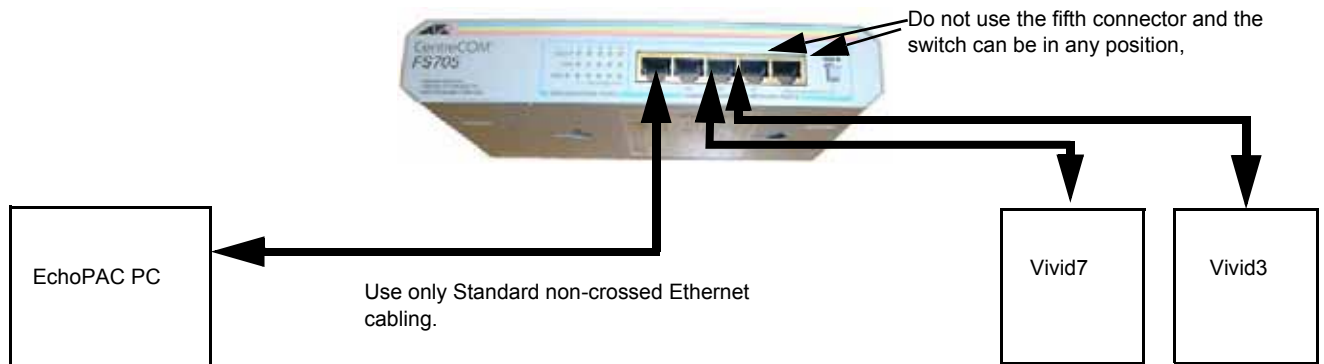

Figure 3-31 Local Network Connection

3-7-2-3 Hospital Network Connection to EchoPAC PC Workstation

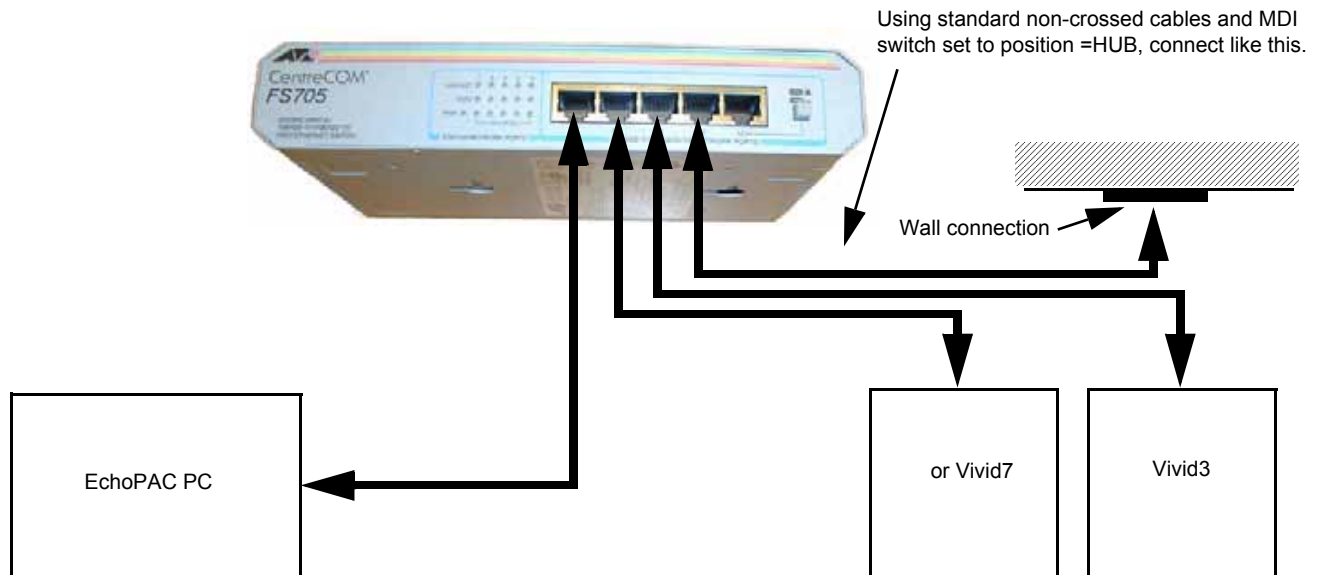

Figure 3-32 Hospital Network Connections

See the EchoPAC PC Service Manual (Part Number EP091298) for details about the EchoPAC PC, and the required set-up procedures.

3-7-3 Setting Up for Connectivity

Notes:

- Four passwords are required to complete the setup of the connectivity options. Ensure that all these passwords are installed on the Vivid™ 3 ultrasound unit before you begin the configuration procedure.
- The 3rd Connector option is available for use with Vivid™ 3 BT03 systems.
- The HL7 option (not listed) is a licence granting permission to connect the system to the HL7 gateway, through the EchoPAC. This function (which is configured on EchoPAC, not on the Vivid™ 3 system) is used to export examination results to the Hospital Information System (HIS), through HL7 protocol. Users requiring this option should contact the GE representative.

- 1) Press **Config** on the alphanumeric keyboard. The *System Configuration* window is displayed.
- 2) Trackball to the **System Options** tab and press **Select**. The **System Options** tab is displayed, as shown below:

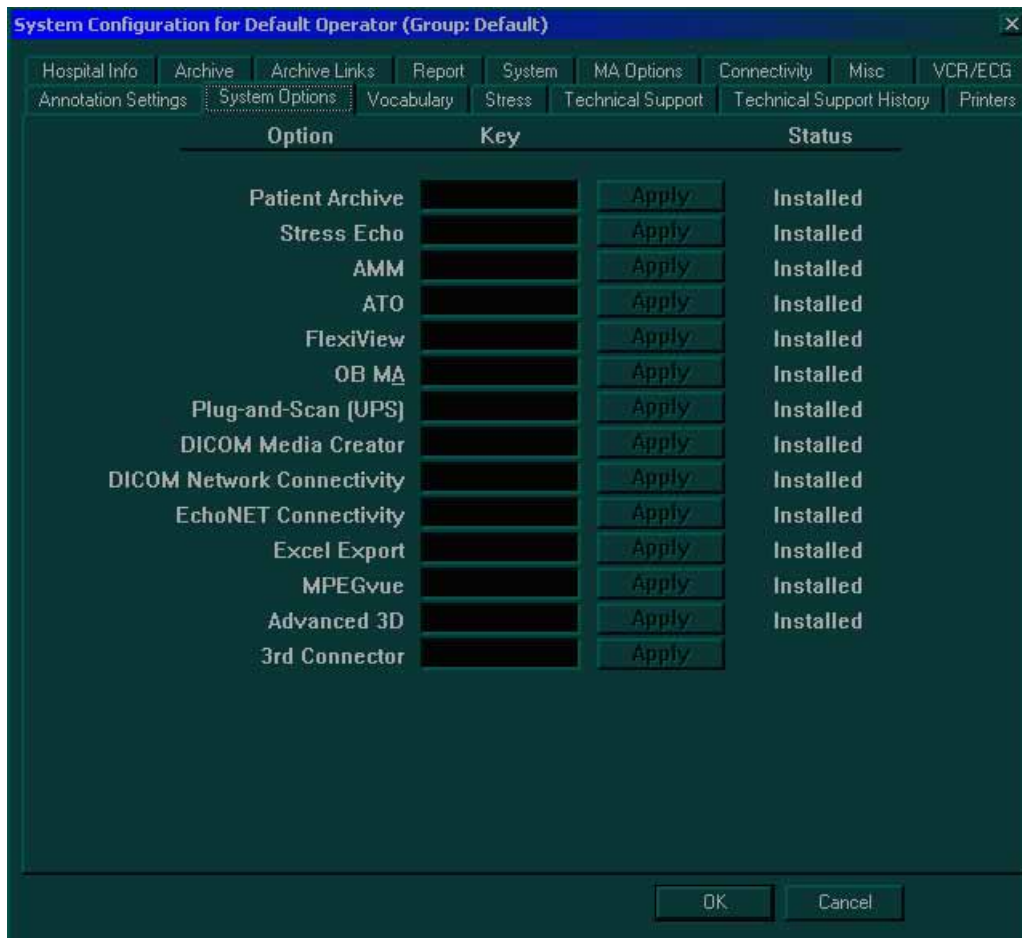

Figure 3-33 System Options Tab

- 3) Verify that the following options are installed, as required:
 - **DICOM Media Creator** is required to support DICOM storage to MOD or CD-R media.
 - **DICOM Network Connectivity** is required to support DICOM storage over the network, for example, to Proslov.
 - **EchoNET Connectivity** is required to support an EchoPAC direct connection.
 - **Excel Export** is required to support the ability to export measurements and reports to Microsoft Excel files.
- 4) Enable the **DICOM printer** option, as required (under the *Services* sub-tab) - see [Figure 3-34](#).

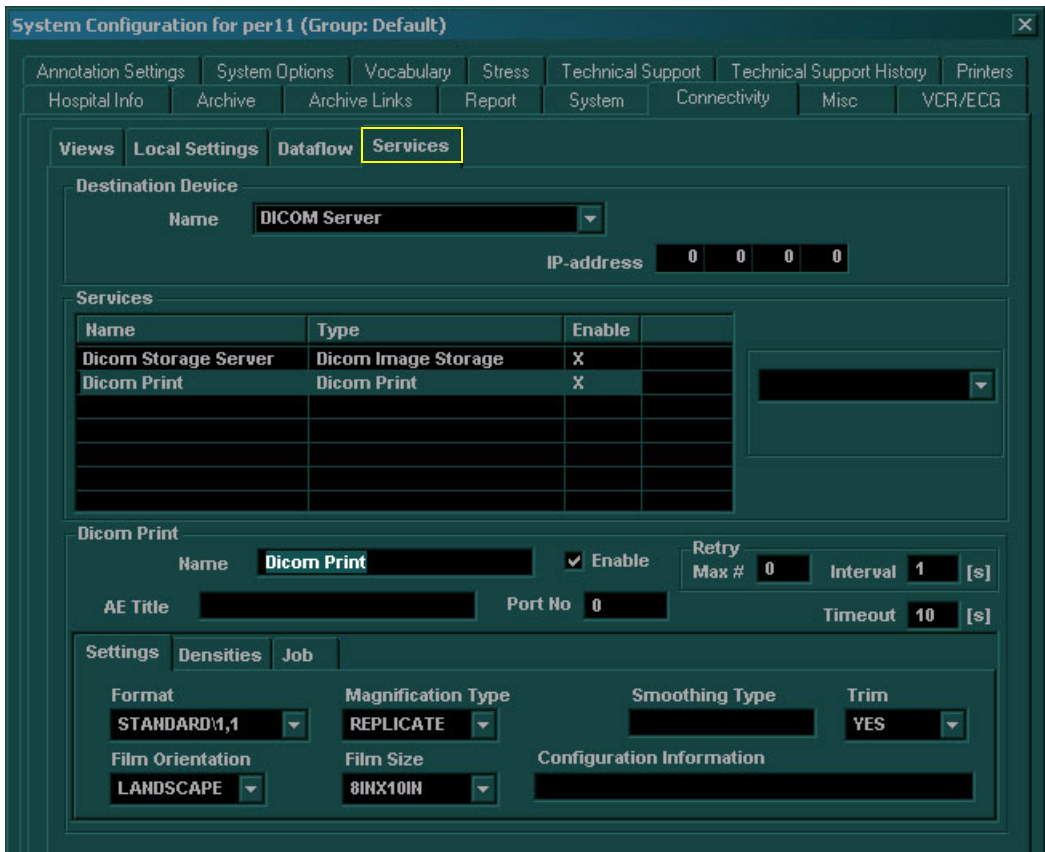

Figure 3-34 Setting up DICOM Print

- 5) Enable any other remote server, as required (for example, Services, My Computer, select **MPEGvueCDR** as shown in [Figure 3-35](#)).

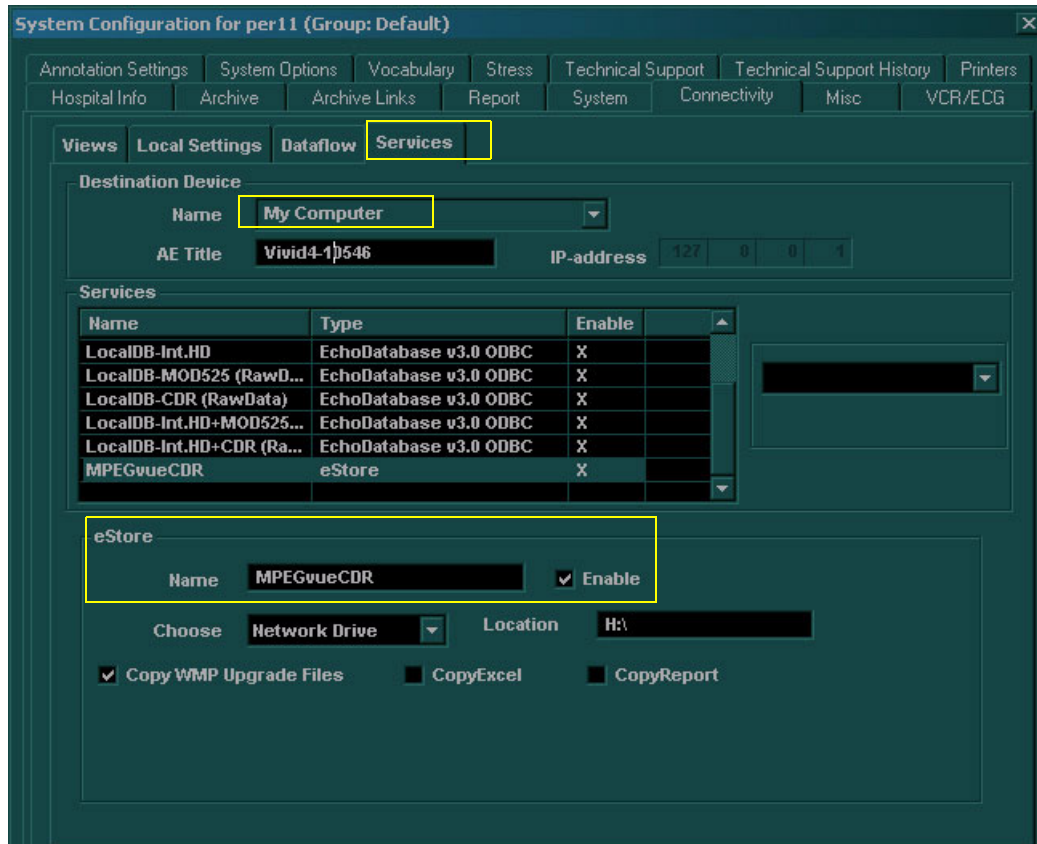

Figure 3-35 Setting up Remote Server for MPEGvue

- 6) When done, trackball to the **OK** button and press **Select**.
- 7) Trackball to the **OK** button and press **Select**.

3-7-4 Setting Up the Network Connection

- 1) Press **Config** on the alphanumeric keyboard. The *System Configuration* window is displayed.
- 2) Trackball to the **Connectivity** tab and press **Select**. The **Connectivity** tab is displayed, with the **Views** subsidiary tab selected by default, as shown below:

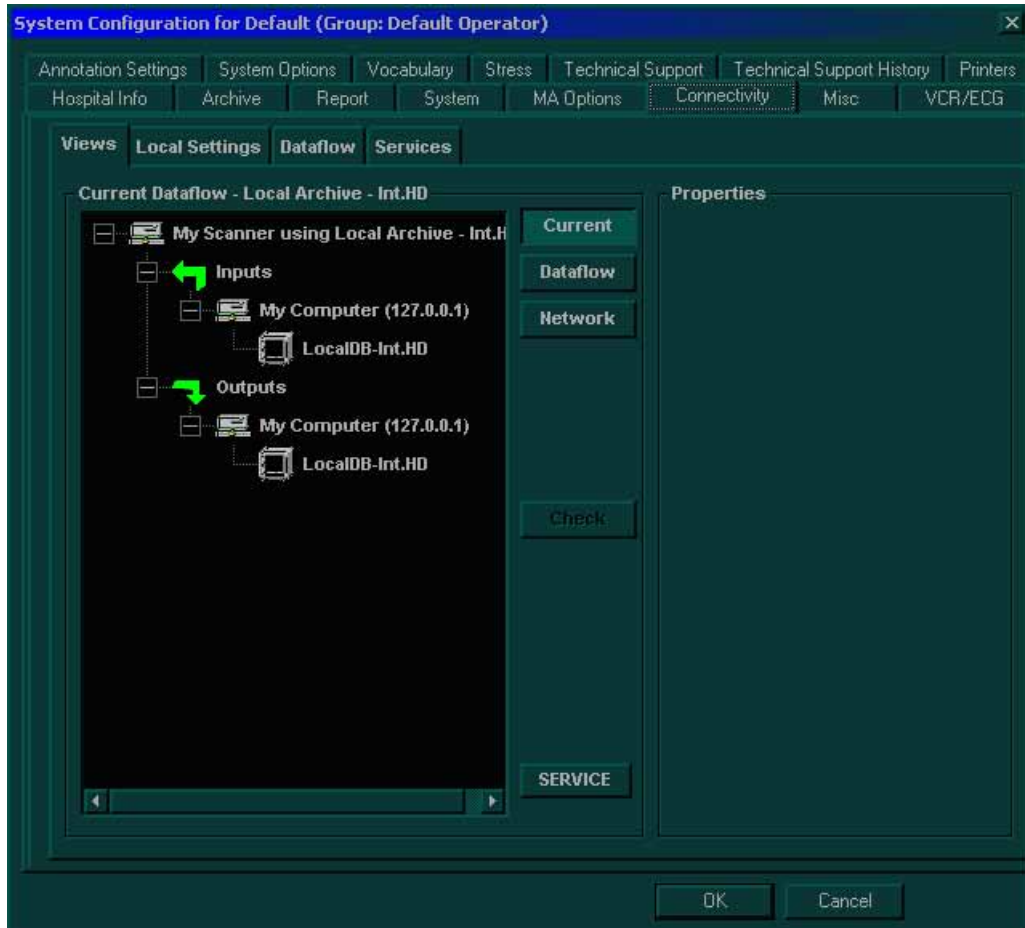

Figure 3-36 Connectivity Tab

- 3) Trackball to the **SERVICE** button at the bottom of the **Views** tab, and press **Select**. The following dialog box is displayed:

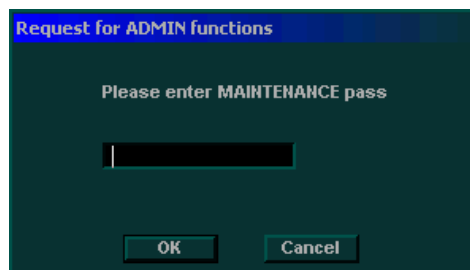

Figure 3-37 Password Request Dialog Box

- 4) Enter the password **geulsservice**, and then trackball to the **OK** button and press **Select**.

- 5) Trackball to the **Local Settings** tab and press **Select**. The **Local Settings** tab is displayed, as shown below.

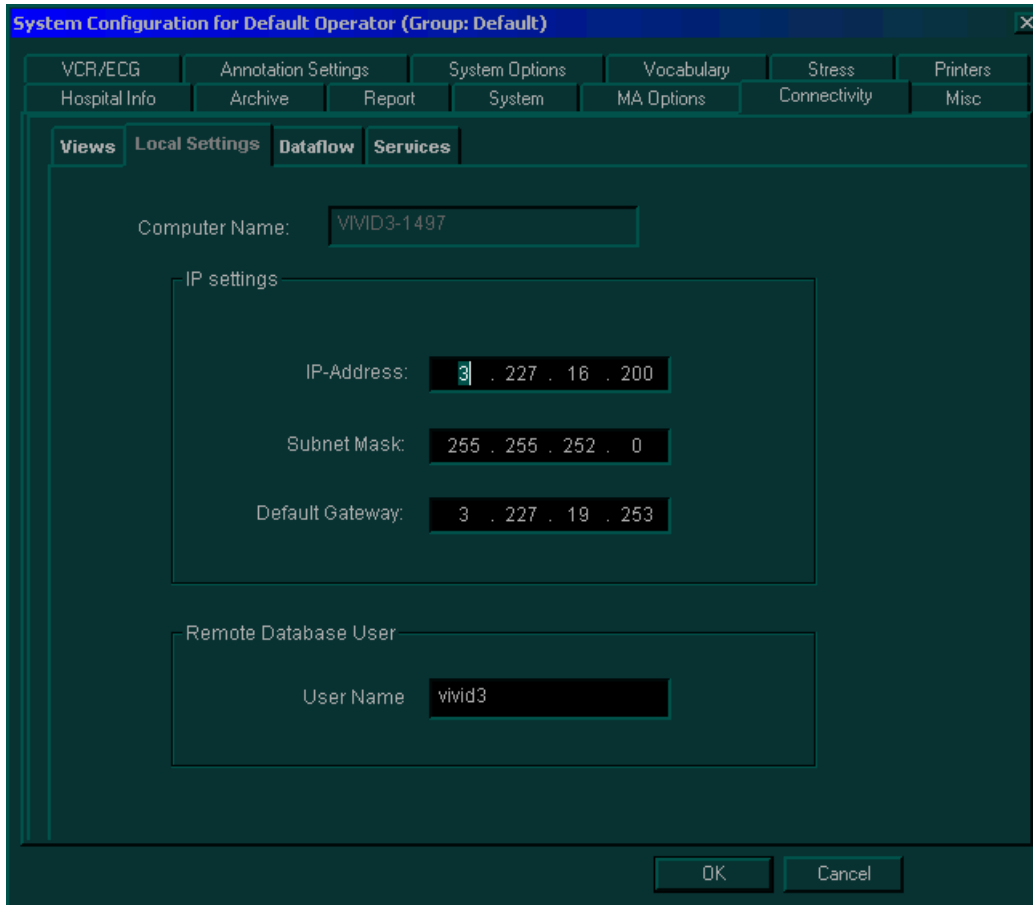

Figure 3-38 Local Settings Tab

Note: The *Computer Name* field shows the serial number of your Vivid™ 3 system.

- 6) Enter the network information in the appropriate fields. Leave the **User Name** as **vivid3**.

Note: The **Default Gateway** option is not always required. If this address is not supplied by the system administrator, leave it blank.

- 7) Trackball to the **OK** button and press **Select**. The following warning is displayed:

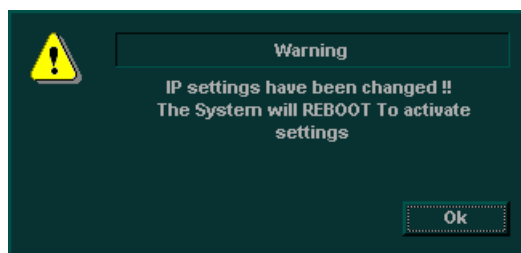

- 8) Trackball to the **OK** button and press **Select**. The system will reboot to activate the settings.

3-7-5 Setting Up for Communication with a Prosolv Workstation

The Vivid™ 3 ultrasound unit can connect to a Prosolv DICOM viewer through a DICOM server. The unit cannot connect directly to the viewer.

- 1) Setup the network connection, as described in the the *Setting Up the Network Connection* section, on page 3-55.
- 2) Press **Config** on the alphanumeric keyboard. The *System Configuration* window is displayed.
- 3) Trackball to the **Connectivity** tab and press **Select**. The **Connectivity** tab is displayed, with the **Views** subsidiary tab selected by default, as shown in [Figure 3-36](#) on page 3-55.
- 4) Trackball to the **SERVICE** button at the bottom of the **Views** tab, and press **Select**. The password request dialog box (shown in [Figure 3-37](#) on page 3-55) is displayed.
- 5) Enter the password **geulsservice**, and then trackball to the **OK** button and press **Select**.
- 6) Trackball to the **Services** tab and press **Select**. The **Services** tab is displayed, as shown below:

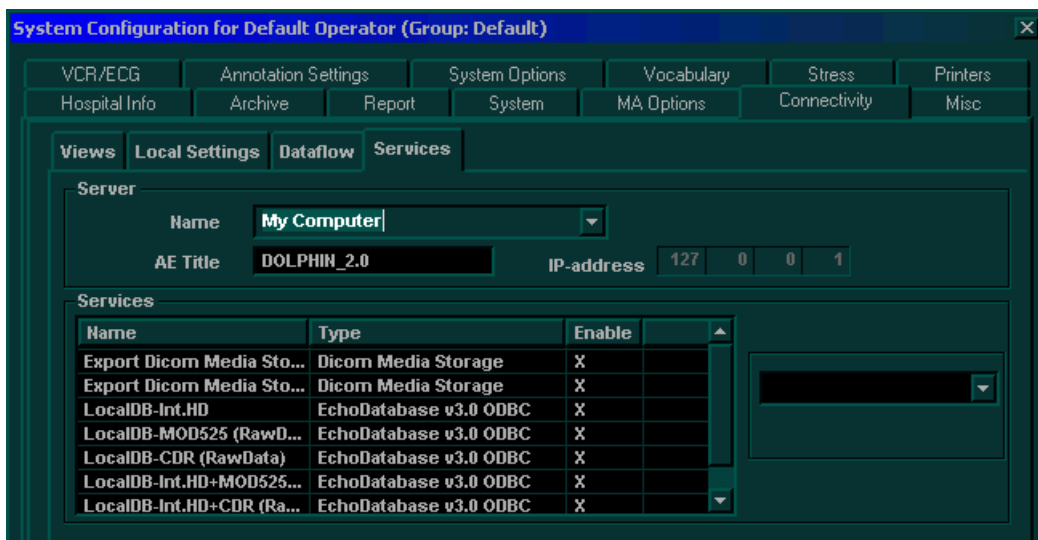

Figure 3-39 Services Tab

- 7) Select **DICOM Server** from the **Name** dropdown list. The **Services** tab is updated, as shown below

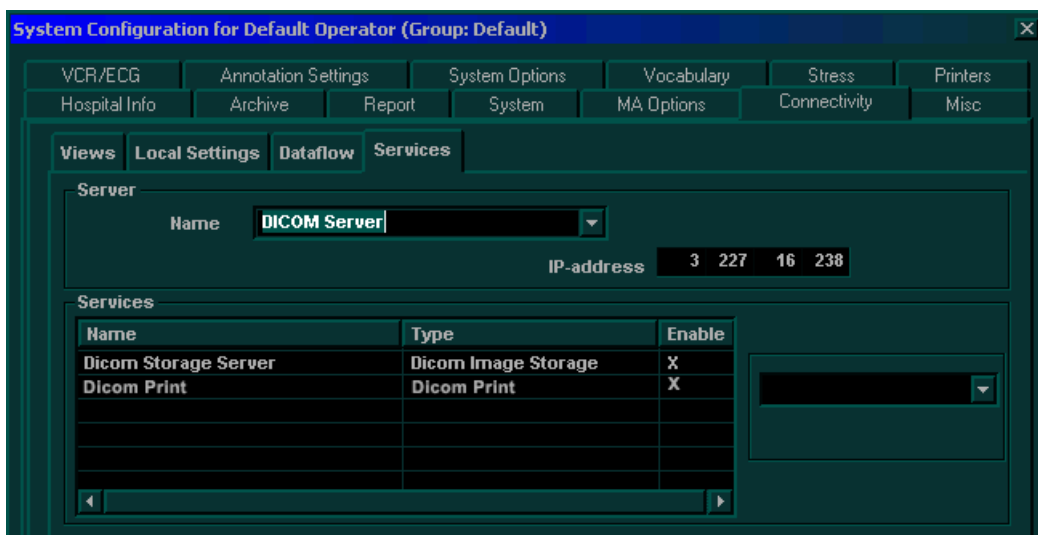

Figure 3-40 Services for DICOM Server

- 8) Enter the IP address for the DICOM server in the **IP-address** field.
- 9) Trackball to the **Dicom Storage Server** line in the **Services** table. The **Services** tab is expanded, as shown below:

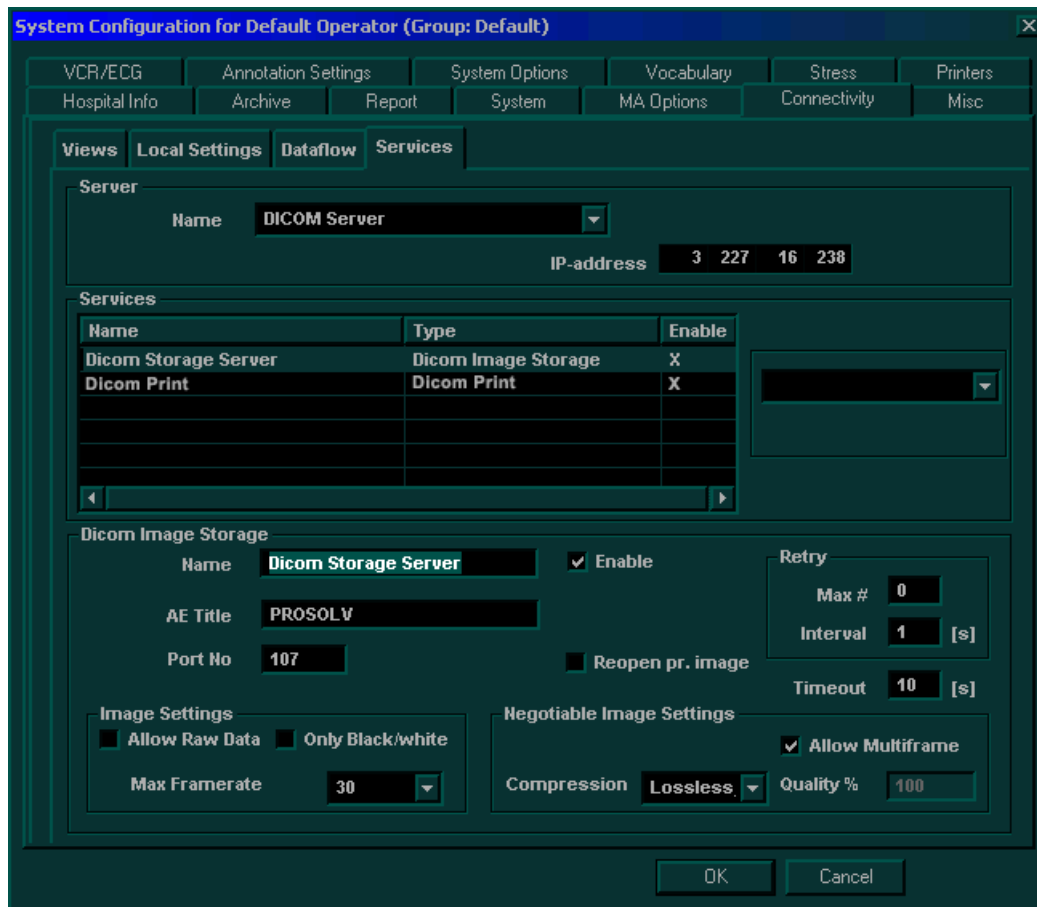

Figure 3-41 Connectivity Tab (Services for DICOM Server Expanded)

- 10) Enter the **AE Title** and the **Port No** of the DICOM server in the appropriate fields.

Note: Ensure that the **Allow Raw Data** checkbox is *deselected*.

- 11) Trackball to the **Dicom Print** line in the **Services** table. The **Services** tab is expanded, as shown in [Figure 3-42](#) below.

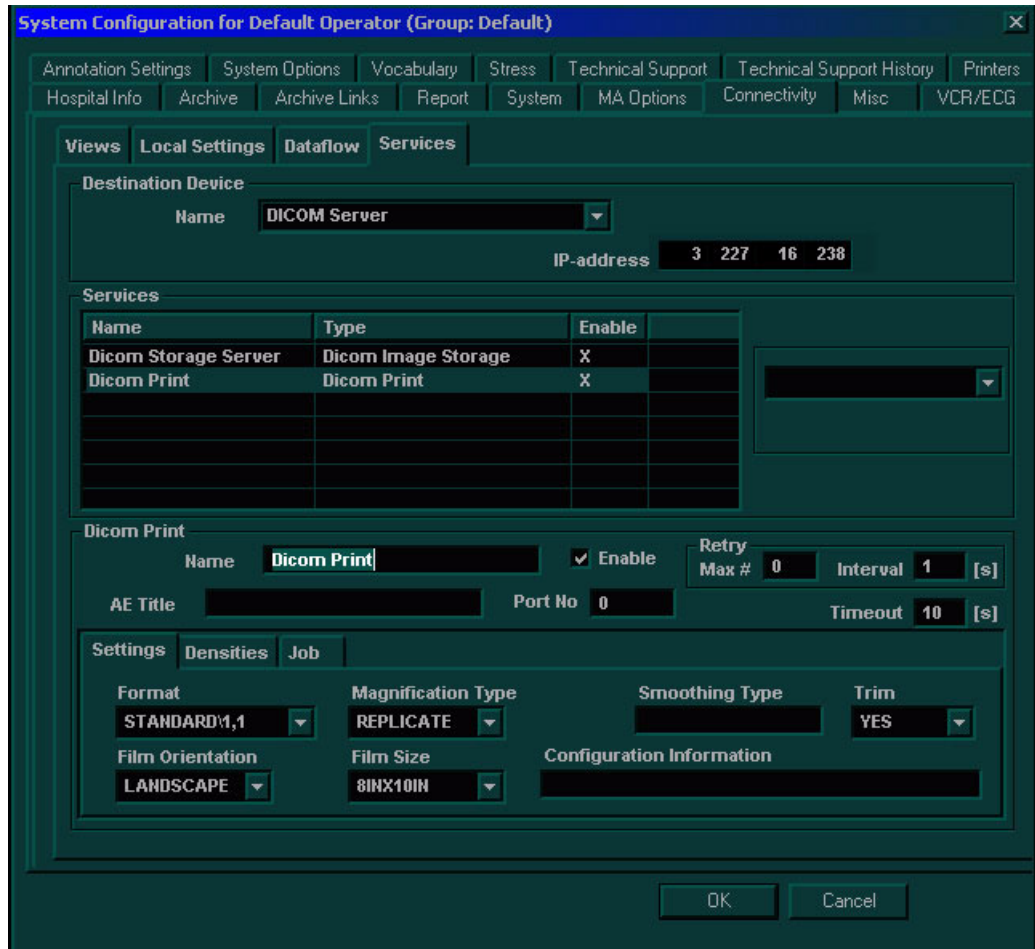

Figure 3-42 Connectivity Tab (Services for DICOM Print Expanded)

- 12) Under *Settings*, select the required **Format**, **Film Orientation**, etc.
- 13.) Proceed to the next section, to perform the procedure for validating communication with the DICOM server.

3-7-5-1 Validating Communication with the DICOM Server

- 1) Trackball to the **Views** tab and press **Select**. The **Views** tab is displayed.
- 2) Trackball to the **Dataflow** button and press **Select**. The full list of data flows is displayed:

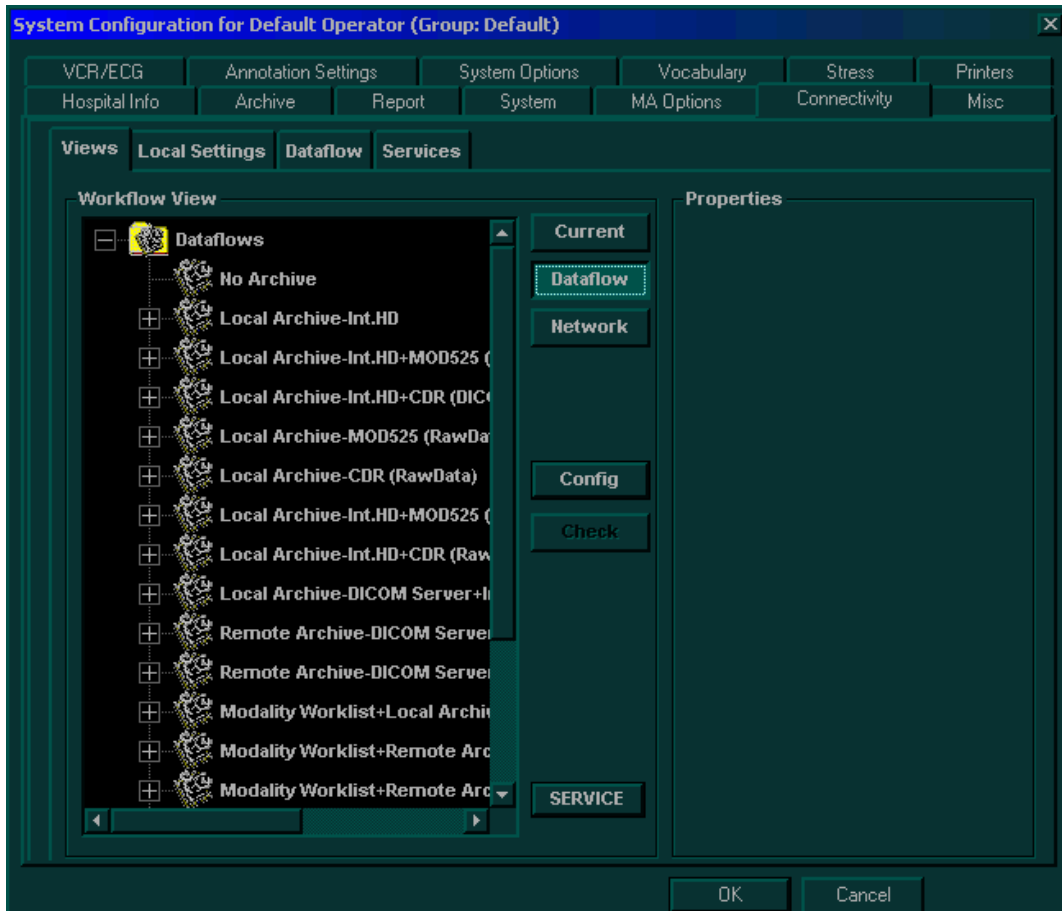

Figure 3-43 Views Tab

NOTE: **IMPORTANT INFORMATION ABOUT DATAFLOWS:**
The system's default dataflow is **Local Archive - Int. HD**. In this configuration, the Patient List is in the local archive and the images are stored on the internal hard drive.
In a dataflow configuration such as **Int. HD - MOD 525 (DICOM)**, images are stored both on the internal hard drive and on media (MOD). The name DICOM is shown in parenthesis, signifying that on the MOD, the images are in DICOM format.
No Archive is a dataflow that has no output source, for use in emergencies.



CAUTION: DO NOT change the name of an existing dataflow or attempt to add new services to a dataflow! In the event that any changes or additions are required, contact the On-line Center.

- 3) Expand the **Local Archive-Int. HD + DICOM Server** branch. The service DICOM Server is displayed.
- 4) Trackball to **DICOM Server** and press **Select**, then trackball to the **Check** button and press select.
 - If the connection is established, a green checkmark is displayed.
 - If the connection cannot be established, a red cross is displayed.

- 5) If the connection was successfully established, trackball to the **Dicom Storage Server** line and press **Select**, then trackball to the **Check** button and press **Select**.
 - If the connection is established, a green checkmark is displayed.
 - If the connection cannot be established, a red cross is displayed.Properties of the DICOM storage server configuration are displayed on the right side of the tab, as reference.
- 6) If the connection was successfully established, trackball to the **Dicom Print** line and press **Select**, then trackball to the **Check** button and press **Select**.
 - If the connection is established, a green checkmark is displayed.
 - If the connection cannot be established, a red cross is displayed.
- 7) If all connections were established successfully, click **OK** to exit the configuration procedure. If not, review the entire procedure to locate the error.

3-7-5-2 Validating Communication with the Workstation

- 1) Press the **Archive** button on the control panel. The *Patient List* window is displayed, as shown below:

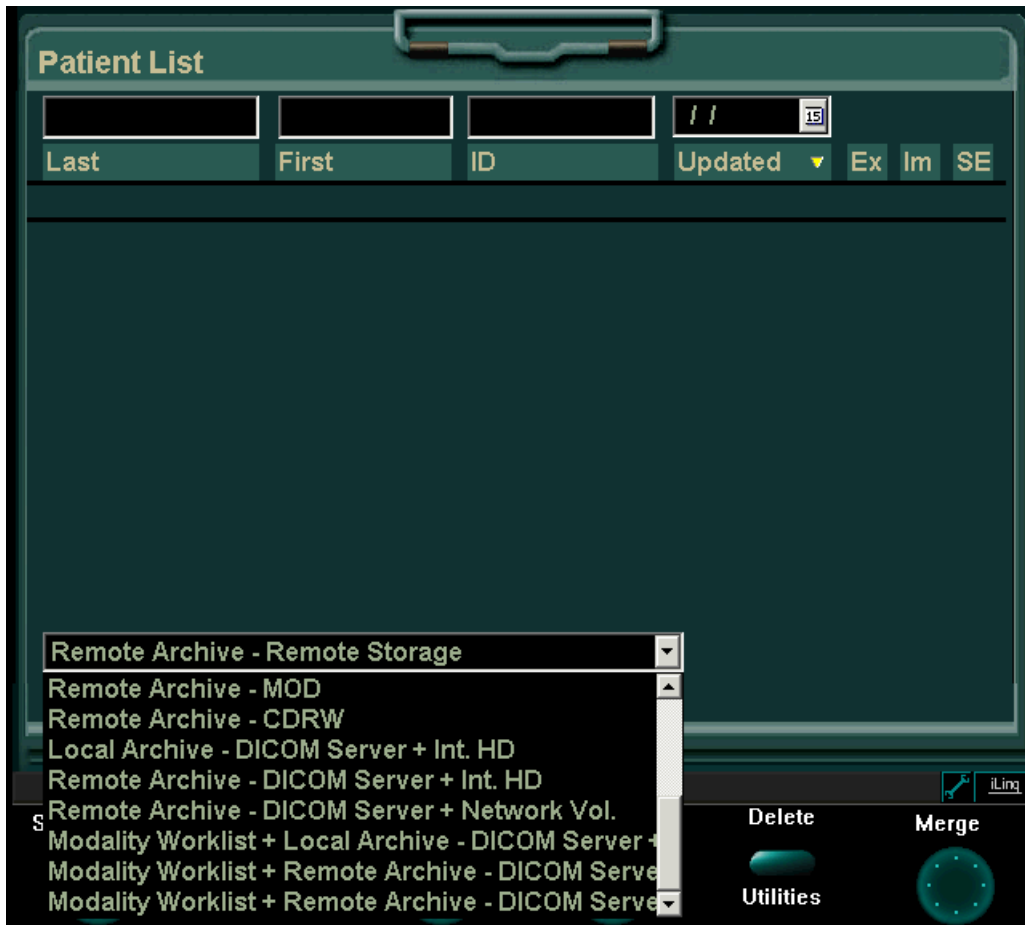

Figure 3-44 Patient List Window

- 2) Select the **Local Archive-Int. HD + DICOM Server** option from the drop-down list at the bottom of the window. If the system will not accept the dataflow, or displays an error message, there is an error in dataflow communication.
- 3) Begin an exam for a new patient and store some images. The storage process will take longer as each loop is now stored in both raw data and DICOM format.
- 4) Begin an exam for a new patient. Once the second patient is active, the first patient's exam is closed and sent to the spooler to be sent over the network.

5) Press <Ctrl+S> to view the status of the spooler, as shown below:



Figure 3-45 Job Spooler

The **Status** column can contain the following options:

- **Hold:** Images are in the spooler buffer but transmission has not begun as the exam is active.
- **Active:** Images are being transmitted over the network.
- **Done:** Transmission is complete and all the images have been transmitted over the network.
- **Fail:** Transmission failed or is incomplete. An error message will be displayed in the **Error** column.

3-7-6 Connecting Directly to EchoPAC

Note: The EchoPAC station will reject any images that have a future date. Ensure that the clock on the Vivid™ 3 ultrasound unit lags behind that of the EchoPAC system by a minute or two.

- 1) Press **Config** on the alphanumeric keyboard. The *System Configuration* window is displayed.
- 2) Trackball to the **Connectivity** tab and press **Select**. The **Connectivity** tab is displayed, with the **Views** subsidiary tab selected by default, as shown in [Figure 3-36](#) on page 3-55.
- 3) Trackball to the **Dataflow** button and press **Select**. The full list of data flows is displayed, as shown in [Figure 3-43](#) on page 3-60.
- 4) Expand the **Remote Archive - Remote Storage** branch. A service called **Remote Servers** is displayed.
- 5) Expand the **Remote Servers** branch. A service called **Remote Archive - Remote Storage** is displayed.
- 6) Trackball to the **Services** tab and press **Select**. The **Services** tab is displayed, as shown in [Figure 3-39](#) on page 3-57.

- 7) Select the EchoPAC server from the **Name** dropdown list. The **Services** tab is updated, as shown below:

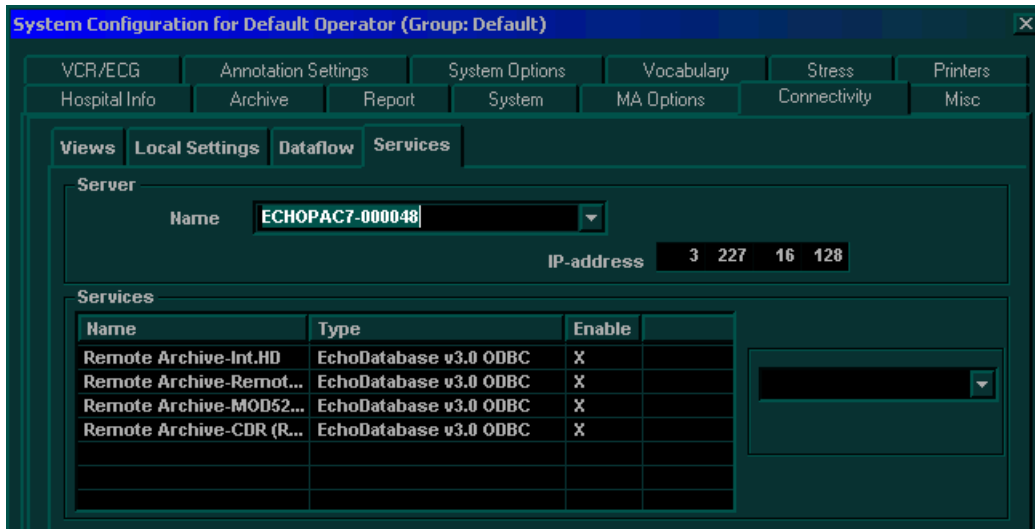

Figure 3-46 Services Tab - EchoPAC

- 8) Enter the IP address of the EchoPAC server in the **IP-address** field.
- 9) Select the **Remote Archive - Remote Storage** line from the **Services** table. The **Services** tab is expanded, as shown below:

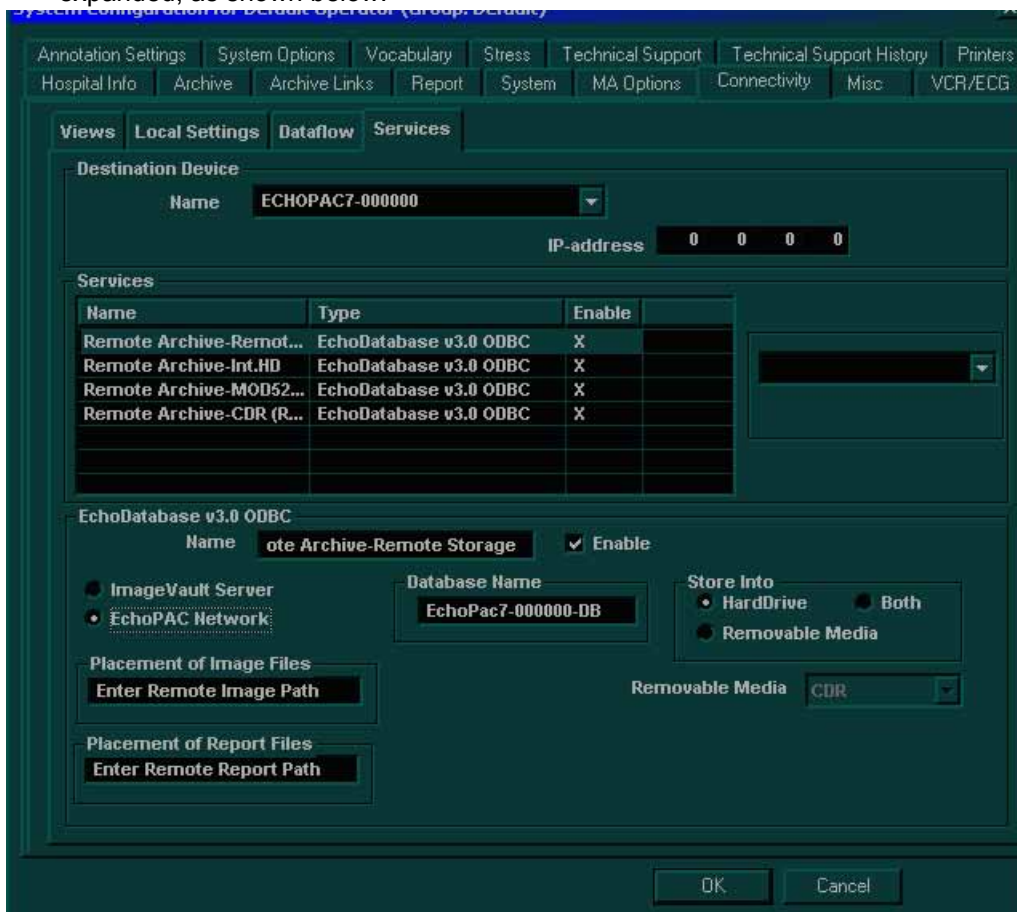

Figure 3-47 Services Tab - EchoPAC Expanded

10) If *EchoPAC Network* is required, make sure that the **EchoPAC Network** checkbox is *selected*, as shown in [Figure 3-47](#), above, then proceed as follows:

- a.) Enter **ECHOPAC7-000XXX-DB** in the **Database Name** field.
- b.) Under *Store Info*, select the appropriate checkbox **Hard Drive**, **Removable Media**, or **Both**, as required.
- c.) Enter **\\ECHOPAC7-000XXX\Archive** in the **Placement of Image Files** field.
- d.) Enter **\\ECHOPAC7-000XXX\Archive** in the **Placement of Report Files** field.

OR

If *Image Vault Server* is required, make sure that the **Image Vault Server** checkbox is *selected*, as shown in [Figure 3-48](#) below, then proceed as follows:

- a.) Enter **ECHOPAC7-000XXX-DB** in the **Database Name** field.
- b.) Under *Store Info*, make sure that the **Hard Drive** checkbox is selected.
- c.) Enter **\\ECHOPAC7-000XXX\Archive** in the **Placement of Image Files** field.
- d.) *Select* the **Allow Multiframe** and/or **Allow Raw Data** checkboxes, as required. (It is recommended to leave both checkboxes activated, as shown in [Figure 3-48](#) below).
- e.) Under the *Image Settings* field, select the required settings.

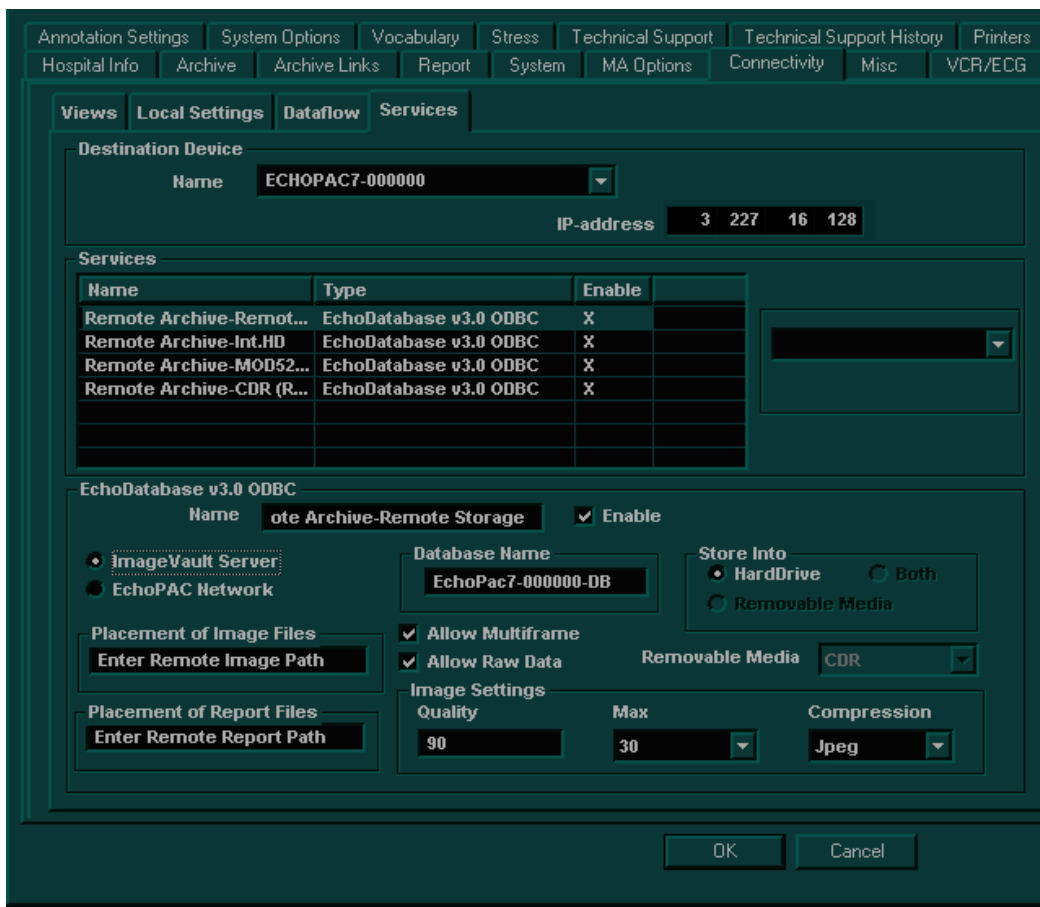

Figure 3-48 Services Tab - Image Vault Server Expanded

3-7-6-1 Validating Communication with the EchoPAC Server

- 1) Trackball to the **Views** tab and press **Select**. The **Views** tab is displayed.
- 2) Trackball to the **Dataflow** button and press **Select**. The full list of data flows is displayed, as shown below.

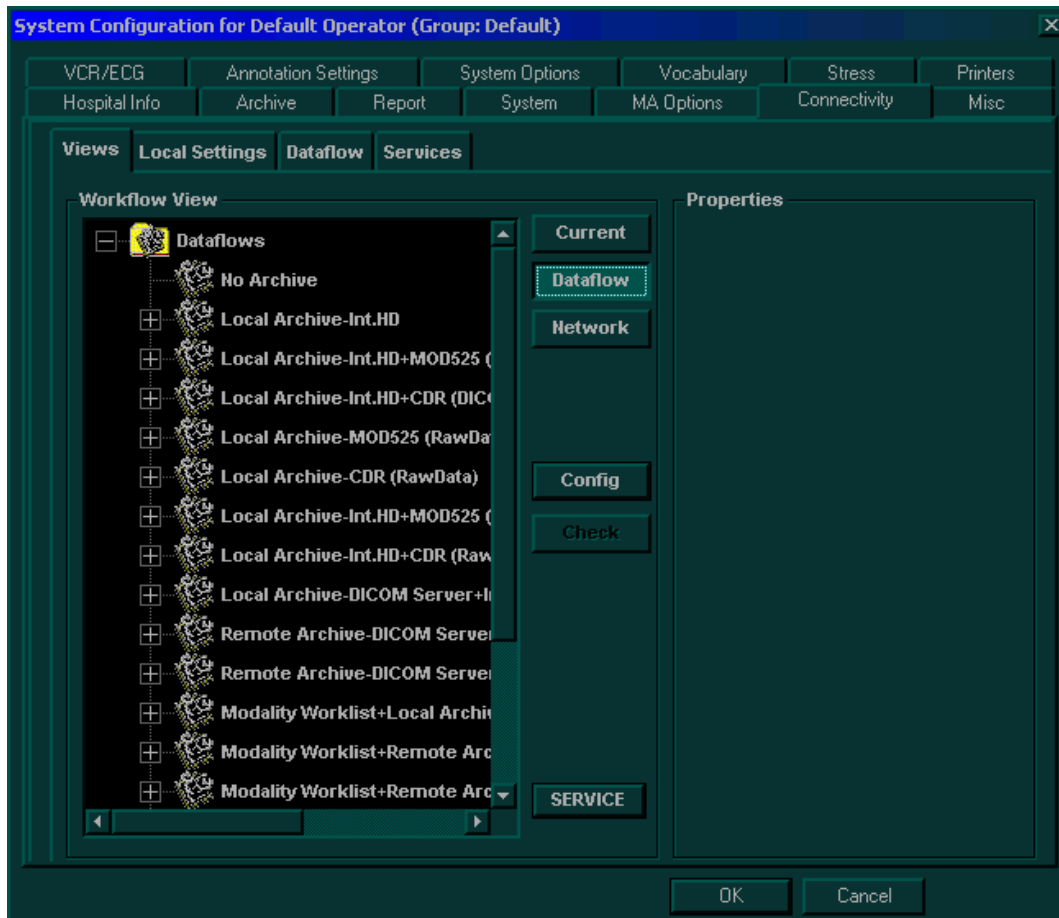

Figure 3-49 Views Tab

- 3) Expand the **Remote Archive - Remote Storage** branch. A service called **Remote Servers** is displayed.
- 4) Expand the **Remote Servers** branch. A service called **Remote Archive-Remote Storage** is displayed.
- 5) Trackball to **Remote Servers** and press **Select**, then trackball to the **Check** button and press **Select**.
 - If the connection is established, a *green checkmark* is displayed.
 - If the connection cannot be established, a *red cross* is displayed.
- 6) If the connection was successfully established, trackball to the **Remote Archive-Remote Storage** line and press **Select**, then trackball to the **Check** button and press **Select**.
 - If the connection is established, a *green checkmark* is displayed.
 - If the connection cannot be established, a *red cross* is displayed.
- 7) If both connections were established, click **OK** to exit the configuration procedure. If not, review the entire procedure to locate the error.

NOTE: **IMPORTANT INFORMATION ABOUT DATAFLOWS:**
The system's default dataflow is **Local Archive - Int. HD**. In this configuration, the *Patient List* is in the local archive and the images are stored on the internal hard drive.
In a dataflow configuration such as **Int. HD - MOD 525 (DICOM)**, images are stored both on the internal hard drive and on media (MOD). The name DICOM is shown in parenthesis, signifying that on the MOD, the images are in DICOM format.
No Archive is a dataflow that has no output source, for use in emergencies.



CAUTION: DO NOT change the name of an existing dataflow or attempt to add new services to a dataflow! In the event that any changes or additions are required, contact the On-line Center.

3-7-6-2 Validating EchoPAC or Image Vault Operation

- 1) Press the **Archive** button on the control console. The *Patient List* window is displayed, as shown in [Figure 3-44](#) on page 3-62.
- 2) Select the **Remote Archive-Remote Storage** option from the dropdown list at the bottom of the window. If the system will not accept the dataflow, or displays an error message, there is an error in dataflow communication.
- 3) Begin an exam for a new patient and store some images. The storage process will take longer as each loop is now stored in both raw data and DICOM format.
- 4) Begin an exam for a new patient. Once the second patient is active, the first patient's exam is closed and sent to the spooler to be sent over the network.
- 5) Press **<Ctrl+S>** to view the status of the spooler, as described on page [3-63](#).

Section 3-8 Storing and Transporting the Unit

The Vivid™ 3 ultrasound unit weighs up to 160 kg (353 lbs), depending on the configuration. To avoid equipment damage and ensure maximum safety while transporting or moving the unit, the following precautions are recommended:

- Before moving, prepare the unit, as described in the *Preparing the Unit for Transport* section, below.
- While moving the unit, follow all safety precautions, as described in the *Safety Precautions for Moving the Vivid™ 3 Unit* section, below.
- When transporting the unit by vehicle, or shipping by air or any other means:
 - Pack the unit in the original packing, as described in the *Packing the Unit into the Wooden Shipping Crate* section, on page 3-71, or the *Packing the Unit in the Cardboard Shipping Carton* section, on page 3-74.
 - Follow all safety precautions.
 - Handle with care.
- When reinstalling the unit, allow sufficient system acclimation time, as described in the *System Acclimation Time* section, on page 3-2.

3-8-1 Disconnecting the Unit when Storing



CAUTION: Never disconnect the power (switch OFF the system circuit breaker or unplug the power plug) before the system is completely shut down. Power disconnection before full system shutdown may cause system boot-up failure. This may require system recovery, by booting-up the system using the software CD.

Before storing the unit or moving it to another site, disconnect the unit as follows:

- 1) Press the **On/Off** button on the control panel for 5 seconds. A menu is displayed.
- 2) Select **Full Shutdown** from the displayed menu.
- 3) Turn the circuit breaker to OFF.
- 4) Unplug the power cord from the mains power outlet.
- 5) Loop the cord around the hook on the unit's rear panel.

3-8-2 Preparing the Unit for Transport

Perform the following steps as applicable:

- 1) Turn the system OFF, including the circuit breaker at the rear of the unit, and remove the plug from the wall.
- 2) Disconnect all cables linking the unit to any off-board peripheral devices, such as a computer network, printers, etc. Note the marks on each cable, in order to reconnect them later.
- 3) Secure the unit's power cable.
- 4) Place all probes in the probe holders. Wrap or place the probe cables on the cable hooks at the front of the unit to ensure that they do not protrude from the unit or interfere with the wheels. Store all other probes in their original cases, soft cloth or foam to prevent damage. The park-port may also be used for a probe connection although it is not active.
- 5) Ensure that no loose items are left on the unit.
- 6) Unlock the brakes by pressing down on the pedal to return it to the middle position.

3-8-3 Safety Precautions for Moving the Vivid™ 3 Unit



CAUTION: Whenever moving the Vivid™ 3 ultrasound unit, always observe the following safety precautions:



- 1) Proceed cautiously when crossing door or elevator thresholds. Grasp the front handle grips or the back handle bar, and then push or pull. **DO NOT** attempt to move the unit by pulling its cables or probe connectors.
- 2) Ensure that the unit does not strike walls or door frames.
- 3) Ensure that the pathway is clear.
- 4) Move the unit slowly and carefully.
- 5) Take extra care while moving the unit long distances and on inclines.
- 6) Avoid ramps with an incline of greater than ten degrees to prevent the unit from tipping over. Once the destination is reached, lock the front wheel brakes.

3-8-4 Wooden Shipping Crate and Packaging Materials

Verify that the following packing materials are available. All these materials are required to safely package the Vivid™ 3 ultrasound unit in the wooden shipping crate for shipment by vehicle, or any other means.

Table 3-20 Packaging Materials for the Wooden Shipping Crate

Item	Description	Qty
1	Crate base	1
2	Antistatic sheet, 2.2x3m	1
3	Top cover/ramp	1
4	Antistatic bag	1
5	Silica gel bag	3
6	Right side wall	1
7	Left side wall	1
8	Front foam	1
9	Back foam	1
10	Keyboard foam	1
11	Back foam, top	1
12	Monitor foam	2
13	Front wall	1
14	Rear wall	1
15	Clips, Clip-lok™	32
16	Steel strip	14
17	Shockwatch label	2
18	Fragile label	2
19	Carton box, flat	2
20	UP label	2
21	Shipping label	2
22	CE label	1
23	Hand level clip remover	1
24	Press-on envelope	2

3-8-5 Cardboard Shipping Carton and Packaging Materials

Verify that the following packing materials are available. All these materials are required to safely package and transport the Vivid™ 3 ultrasound unit in the cardboard shipping carton for shipment by vehicle, or any other means.

Table 3-21 Packaging Materials for the Cardboard Shipping Crate

Item	Description	Qty
1	Press-on envelope	2
2	Product Label	1
3	Input Pwr. Cable	1
4	Platform (wooden base)	1
5	Ramp	1
6	Antistatic nylon	6.6m
7	Silica gel bag	3
8	Cardboard Package Carton	1
9	Gel Support	2
10	Monitor Support	1
11	Antistatic bag	1
12	Carton cover	1
13	Steel strip	15m
14	Cellotape	20m
15	Staple	22
16	Wood screw	2
17	Fragile label	2
18	Up label	2
19	CE label	1
20	S/N label	1
21	Tax security code label	2
22	Shockwatch label	2
23	Shipping label	2
24	Product locator card	2 (16)
25	Front stopper release label	2

3-8-6 Packing the Unit into the Wooden Shipping Crate

Note: For details of item numbers in this procedure, refer to the following figures:

- [Figure 3-1](#) on page 3-4
- [Figure 3-3](#) on page 3-6
- [Figure 3-4](#) on page 3-7
- [Figure 3-5](#) on page 3-7.

- 1) Turn OFF the unit by pressing the ON/OFF button on the control console.
- 2) Turn OFF the AC circuit breaker on the rear of the unit.
- 3) Disconnect the mains power plug from the wall outlet.
- 4) Unplug any probes connected to the unit, and store them in their original cases.
- 5) Disconnect and remove all external cables from the right and left rear panels and the ECG cable connected to the front panel.
- 6) Verify the presence of all the external cables listed in [Table 3-4 on page 3-13](#), and pack them in carton A (item 19).
- 7) Release and unplug the power cable connector from the AC input at the rear of the unit, and loop it on the hook located on the rear cover.
- 8) Unplug the AC power cable from the monitor.
- 9) Verify the presence of all the accessories listed in [Table 3-5 on page 3-14](#), and pack them in carton B (item 19).
- 10) Pack the User Manual and any other manuals in an antistatic bag (item 4).
- 11) Lay the case base on the floor, with the two wood strips facing upwards.
- 12) Cover the top side of the base with the antistatic sheet 2.2 m x 3m (7.2 ft x 10 ft) (item 2).
- 13) Lay the top cover/ramp (item 3) on the floor and push it over the narrow side of the case base, in front of the unit.

Note: The top cover serves first as a ramp on which to roll the unit onto the crate base, and later as the crate top cover.

- 14) Turn the unit's front wheels inwards and parallel to the unit and lock their swivel movement by pressing the brake pedal down to the right.
- 15) Push the unit using its front handle and roll it over the ramp on top of the antistatic sheet that was previously placed on the crate base, until the front wheels touch the halting wood strips on each side of the crate base.
- 16) Move the rear wheels inwards and parallel to the unit and lock all four wheels by pressing the brake pedal down to the left.
- 17) Remove the top cover (ramp) (item 3) and put aside.
- 18) Place three Silica gel bags (item 5) in the space under the unit.
- 19) Pull the unit's control console (monitor) up by pressing the release grip located under the center of the unit's front handle.
- 20) Cover the two cartons containing the external cables and accessories with antistatic foam, and lay them in the space below the keyboard and the unit's top cover.

21) Lower the control console (monitor) so that it is pressing down on the two cartons.

NOTICE

Important!

Verify that the height from the crate base to the top of the monitor does not exceed 132cm (52in)

22) Place the pre-packed manuals in the compartment under the monitor.

23) Insert the two monitor support foams (item 12) under the front of the monitor, one on each side.

24) From above, slip the anti-static cover (item 4) over the unit.

25) Wrap the excess antistatic sheet (item 2) that was previously placed on the platform base around the unit and secure it in place with adhesive tape.

26) Assemble the wooden crate, as described in the following section.

3-8-7 Assembling the Wooden Shipping Crate

The Vivid™ 3 ultrasound unit is packed in a wooden shipping crate comprising various sections. These have rebated joints which are fastened together with 32 Clip-lok™ clips that fit into slots. The sections are as follows:

- Case base
- Left wall
- Right wall
- Front wall
- Rear wall
- Top cover/ramp

To ease the identity of the wooden crate sections, there are red marks on the inner surface of the base, the left wall and rear wall. When the case parts are joined correctly, the three red marks should appear next to each other in one corner. The top cover has also a red mark that should be facing downwards in the corner, where the other three marks meet.

Note: Always insert the short leg of a clip in the appropriate slot first, and then, using the heel of your hand, insert the long leg of the clip into the slot located on the part being joined.

- 1) Place the *right* wall (item 6) vertically along the right side of the crate base and secure it to the base using three clips (item 15).
- 2) Place the *left* wall (item 7) vertically along the left side of the case base and secure it to the case base using three clips (item 15).
- 3) Place the wooden cover (item 3) on top of the right and left side walls and fasten it with three clips (item 15) to each of the side walls.
- 4) Insert the front support foam (item 8) in front of the front wheels.
- 5) Place the back support foam (item 9) in front of the rear wheels.
- 6) Place the keyboard support foam (item 10) in front of the keyboard.
- 7) Place the monitor support back foam (item 11) at the monitor's back.
- 8) Put the cases containing the probes (item D) and Peripheral options in their original packing (item E) in the appropriate spaces.
- 9) Hold the rear wall section (item 14) vertically against the rear of the crate and secure it in place using eight clips (item 15).

- 10) Hold the front wall (item 13) vertically against the front of the crate and secure it in place using eight clips (item 15).
- 11) Secure the hand lever (clip remover) tool (item 23) to the outside of the wooden crate, using a screw.
- 12) Secure the box with two steel strip loops (item 16) around the right and left side walls, and one strip loop around the front and back walls.
- 13) Place two shock-watch labels (item 17) and all other labels (items 20 to 25) on the outer sides of the wooden box.

3-8-8 Packing the Unit in the Cardboard Shipping Carton

Note: For details of item numbers in this procedure, refer to the following figures:

- [Figure 3-1](#) on page 3-4
 - [Figure 3-3](#) on page 3-6
 - [Figure 3-4](#) on page 3-7
 - [Figure 3-5](#) on page 3-7.
- 1) Turn OFF the unit by pressing the ON/OFF button on the control console.
 - 2) Turn OFF the AC circuit breaker on the rear of the unit.
 - 3) Disconnect the mains power plug from the wall outlet.
 - 4) Unplug any probes connected to the unit, and store them in their original cases.
 - 5) Disconnect and remove all external cables from the right and left rear panels and the ECG cable connected to the front panel.
 - 6) Verify the presence of all the external cables listed in [Table 3-4 on page 3-13](#), and pack them in a carton.
 - 7) Release and unplug the power cable connector from the AC input at the rear of the unit, and loop it on the hook located on the rear cover.
 - 8) Unplug the AC power cable from the monitor.
 - 9) Verify the presence of all the accessories listed in [Table 3-5 on page 3-14](#), and pack them in a carton.
 - 10) Pack the User Manual and any other manuals in an antistatic bag.
 - 11) Lay the wooden platform (item 4) on the floor. Leave sufficient free space around the platform.
 - 12) Lay the ramp (item 5) on the floor and attach it to the narrow side of the wooden platform (item 4), that has the front stopper next to it.
 - 13) Cover the wooden platform and the ramp with the antistatic sheet (item 6).
 - 14) Release the front stopper pin by sliding the metal sleeve at the pin's locking base upwards, and then turning it towards yourself.
 - 15) Press the brake pedal to the middle position to unlock the wheels.
 - 16) Turn the front wheels inwards and parallel to the unit, and then press the brake to the right to lock the swivel movement.
 - 17) Using the ultrasound unit's front handle, push the unit over the ramp on top of the antistatic sheet, until the unit is stopped by the rear hook (item D) located at the far end of the wooden platform.
 - 18) Lock the front stopper pin by turning the pin to a vertical position and then sliding the sleeve downwards.
 - 19) Press the brake pedal to the left to lock the unit's wheels.
 - 20) Place three Silica gel bags (item 7) on the platform in the space under the unit.
 - 21) Press the release grip located under the center of the front handle and raise the control console (monitor) by pulling it upwards.
 - 22) Cover the two cartons (item 8) containing the external cables and accessories with antistatic foam and lay them in the space below the control console.

- 23) Lower the control console so that it is pressing on the two cartons, and verify that the height from the base of the case to the top of the monitor does not exceed 132cm (52in).
- 24) Put the manuals into the compartment on the left side of the unit.
- 25) Slip the antistatic cover bag (item 11) over the unit from above.
- 26) Wrap the excess antistatic sheet (item 6) that was previously placed in the wooden platform around the unit and secure it in place using adhesive tape.
- 27) Assemble the cardboard shipping carton, as described in the following section.

3-8-9 Assembling the Cardboard Shipping Carton

The Vivid™ 3 ultrasound unit is packed in a cardboard shipping carton consisting of a cardboard carton cover and a wooden platform, that are joined together with clamps and screws. A ramp for rolling the ultrasound unit on and off the platform is also included.

- 1) Ensure that the ultrasound unit was properly packed, that the brake pedal is in the parking position and that the front stopper is locked and prevents the unit from moving on the wooden platform.
- 2) Place the carton cover (item 12) around the wooden platform (item 4), so that the front flap is positioned on the narrow side of the wooden platform.
- 3) Fasten the carton to the wooden platform along the lower right, rear and left sides with two staples (item 15) on each side.
- 4) Lift the ramp (item 5) and place it in the front of the carton.
- 5) Put the accessories carton and probes cartons in their original positions behind the monitor.
- 6) Fold in the front flaps of the carton cover and fasten them with eight staples (item 15) and two wood screws (item 16).
- 7) Fold the two short carton flaps in at the top of the carton case, then fold in the long flaps and fasten them with adhesive tape (item 14).
- 8) Secure the box with two loops of steel strips (item 13) around the right and left side walls, and one loop around the front and rear walls.
- 9) Place two shock-watch labels (item 17) and all other labels (items 20 through 25) on the outer sides of the carton case.

Section 3-9 Completing the Installation Paperwork

NOTE: On completion of a Vivid™ 3 ultrasound scanner installation, it is important to record the relevant System Installation details (see [Table 3-22 below](#)) and Product Locator Installation details (see [Figure 3-50 on page 3-77](#)), for future reference.

3-9-1 System Installation Details

Enter the serial number printed on the main label (refer to the *Main Label* section, on page 1-15), and the other relevant system installation details into the following table:

Table 3-22 System Installation Details

System S/N:	
Location:	
Date:	
Customer Name:	
Service Engineer's Name:	
Comments:	

3-9-2 Product Locator Installation

NOTE: During and after installation, the documentation (i.e. User Manuals, Installation Manuals...) for the peripheral units must be kept as part of the original system documentation. This will ensure that all relevant safety and user information is available during the operation and service of the complete system.

- 1) Verify that all details have been entered in the System Installation Details form, as described in the *System Installation Details* section, above. If this form has not been completed, enter the details now.
- 2) Locate the Product Locator Installation Card(s) that are affixed to the monitor and to each of the peripherals, and fill in all details on both the front and back of the card(s) - see [Figure 3-50 on page 3-77](#).

Note: Step 2 may have been completed already by GE personnel.
The Product Locator Installation Card shown in [Figure 3-50](#) may not be identical to the card(s) provided.

		Return To:	GEMS - Americas Product Locator - W523 P.O. Box 414 Milwaukee, WI 53201-0414	GEMS - Europe Product Locator - DSE/SM 263 rue de la Miniere 78530 Buc, FRANCE	GEMS - Asia Product Locator 4-7-127 Asahioka Hino-shi Tokyo 191, JAPAN
DESCRIPTION	FDA	MODEL	REV	SERIAL	
VIVID3 SYSTEM 240V 50HZ		2262846-5		D0336	
PREPARE FOR ORDERS THAT DO NOT HAVE A LOCATOR INSTALLATION REPORT			CCP	BS	ORD
EVEN LINE NUMBER			DATE MO DA YR JUL-18-2001		
INSTALLATION			LOCATION	ROOM	EMPLOYEE NO
IU NOTE: FOR DEINSTALLATION PURPOSES USE BACK SIDE			MAILING NO		
2262846-5			DESTINATION NAME AND ADDRESS		
			ZIP CODE		

Figure 3-50 Product Locator Installation Card (ICD)

- 3.) Mail the Product Locator Installation Card(s) to the appropriate product center.

3-9-3 User Manual(s)

Check that the correct *Vivid™ 3 Pro/Vivid™ 3 Expert User Manual(s)* for the system (and relevant software revision), is included with the installation. Specific language versions of the *Vivid™ 3 Pro/Vivid™ 3 Expert User Manual* may also be available. Check with your GE Sales Representative for availability.

During and after installation, supplementary documentation (such as, *User Manuals* and *Installation Manuals* for the peripherals) must be kept as part of the original system documentation. This will ensure that all relevant safety and user information is available during the operation and service of the complete system.

Chapter 4

Functional Checks

Section 4-1 Overview

4-1-1 Purpose of Chapter 4

This chapter describes the functional checks that must be performed either as a part of the installation procedure, or as required during servicing and periodic maintenance of the Vivid™ 3 ultrasound scanner.

Note: Refer to [Chapter 7 - Diagnostics/Troubleshooting](#) for detailed descriptions of some of the functional checks described in this chapter.

Table 4-1 Contents in Chapter 4

Section	Description	Page Number
4-1	Overview	4-1
4-2	General Procedures	4-2
4-3	Functional Check	4-3
4-4	Image Testing: 2D/M/CFM/Doppler	4-11
4-5	System Turnover Checklist	4-26
4-6	Site Log	4-33

Section 4-2 General Procedures

4-2-1 Power ON/OFF and Boot-up Tests

Table 4-2 Power ON/OFF and Boot-up Tests

Step	Task	Expected Result(s)
1	Power up the unit by holding down the On/Off button.	Verify that no warning messages are displayed during bootup.
		Verify that all the peripherals are turned ON.
		Verify that all the front-end fans, the back-end fan and the peripherals are working and clean. Listen to fan spinning sound, check filter, go to monitoring and verify that all fans are working.
2	Connect each of the probes available for the system.	Verify that the system properly recognizes each of the probes and displays the correct probe ID.
3	Turn OFF the unit by holding down the On/Off button for no longer than 3 seconds.	Verify that system enters Standby mode, indicated by a the blinking On/Off button text light.
4	Power up the unit by holding down the On/Off button.	Verify that the unit boots up in no longer than 30 seconds.
5	Turn OFF the unit by holding down the On/Off button for no longer than five seconds.	Verify that a window is displayed, enabling you to select either <i>Full Shutdown</i> or <i>Standby</i> .
6	Select the Full Shutdown option.	Verify that the unit enters full shutdown mode, indicated by the On/Off button text being dimmed.
7	Power up the unit by holding down the On/Off button.	Verify that the unit boots up in no longer than three minutes.
8	Turn OFF the unit by holding down the On/Off button for longer than five seconds.	Verify that the unit enters full shutdown mode, indicated by the On/Off button text being dimmed. This procedure should be used only during emergencies.
9	Power up the unit by holding down the On/Off button.	Verify that the unit boots up in no longer than 3 minutes.

4-2-2 Diagnostic Power Supply Test

Refer to the [LVPS Voltage Test](#) on page 7 - 62, and the [HVPS Voltage Test](#) on page 7 - 63 for the power test supply procedures (under the [MUX Diagnostic Tests](#) section).

Note: The mains power supplied to the system, and the internal Vivid™ 3 ultrasound scanner power supplies, are monitored automatically by the scanner - via the MUX board. Any internal power supply voltage failure may indicate that one (or more) of the following is faulty:

- MUX board
- Incoming AC power supply
- One of the internal power supplies

In rare cases, a fault may be present in the Front-end board, or in a probe.

Section 4-3 Functional Check

4-3-1 Basic Controls

4-3-1-1 Keyboard and Footswitch Tests

Table 4-3 Keyboard and Footswitch Tests

Step	Task	Expected Result(s)
1	Start checking the alphanumeric keyboard backlights.	All alphanumeric backlights are off.
2	Perform a manual keyboard test, as described in the Manual External Keyboard Test on page 7 - 73.	
3	Push all the buttons, except Select , Menu and the On/Off button.	Verify that only the correct button is activated on the Diagnostic panel.
4	Push all the rocker switches.	Verify that only the correct rockers are activated on the Diagnostic panel.
5	Rotate the optical encoders.	Verify that only the correct optical encoder rotates smoothly in both directions.
6	Press the optical encoders that can be pressed, except for 2D Gain and Active Gain .	Verify that only the correct soft keys are activated on the Diagnostic panel.
7	Move the TGC sliders one-by-one.	Verify that only the correct slider is moving on the Diagnostic panel.
8	Perform an automatic lights test, as described in the Automatic Lights Test on page 7 - 74.	Verify that all the key LEDs are illuminated one-by-one.
9	Select the Select option.	All the backlights are turned on, one-by-one. Check that the backlights on the extended and alphanumeric keyboards are illuminated.
10	Return to the <i>Test Manager</i> tab and select Lights (Manual) . Select the KB Panel tab and deselect the Select option.	After the Select button LED is deselected, the alphanumeric keyboard LEDs are not illuminated.
11	Connect the footswitch to the connector on the front panel of the unit, and press the right, middle and left of the switch.	Verify that the numbers {68}, {69} and {70} accordingly are displayed on the info bar.
12	Select <Exit> to leave the <i>KB Diagnostic</i> window.	
13	Perform an alphanumeric keyboard diagnostic, as described in the Keyboard Diagnostic Test on page 7 - 76.	Verify that the Caps Lock LED is illuminated when Caps Lock is active. Refer to Table 4-4 below for special keys. The correct keys or key combinations are displayed.

Table 4-4 Alphanumeric Key Combinations

Key Name	Help	Preset	Config	Text	Page Erase	Line Erase	Arrow					Delete Meas.
A/N Key	F1	F2	F3	F4	F5	F6	F7	F8	F9	F10	F11	F12

4-3-1-2 Speakers Tests

Table 4-5 Speakers Test

Step	Task	Expected Result(s)
1	Run the audio diagnostic, as described in the Audio (Doppler Sound Driver) Diagnostic Test on page 7 - 70.	
2	Change the frequency and speaker activity, from <i>right</i> to <i>left</i> .	Verify that there is clear sound from both speakers at all frequencies. Note that <i>right</i> and <i>left</i> are as seen when standing behind the unit.

4-3-1-3 Video Grabbing Test

Table 4-6 Video Grabbing Test

Step	Task	Expected Result(s)
1	Connect the Y/C OUT to the Y/C IN and run the video grabbing calibration, as described in Video Grabbing Calibration on page 6 - 17.	
2	Examine the grabbed image.	Verify that the grabbed image is stable and has similar grey levels to that of the reference image.

4-3-2 Peripherals

4-3-2-1 VCR Test

Table 4-7 VCR Test

Step	Task	Expected Result(s)
1	Connect a Sony 9600 VCR to the system, restart the system and load an SVHS cassette.	Verify that all the following cables are connected: SVHS In/Out, Audio In/Out and RS232.
2	Connect a 3S probe. Reset the VCR counter and press the VCR Record button using the indicated soft keys as displayed on screen.	Verify that the recording indicator (red dot) is displayed on-screen and the tape counter is running on-screen.
3	Activate CW Mode and record 2 minutes of heart scanning or a similar effect using a phantom.	Record 2 minutes of CW scanning.
4	Stop recording and press the Play B. button, then use the Rewind soft key to rewind the cassette to the beginning before pressing the Play soft key.	The recorded Image is played back.
5		Verify that in CW Mode both the <i>left</i> and <i>right</i> audio channels are working, and that the played back audio is similar to the recorded audio in both the <i>left</i> and <i>right</i> speakers.

4-3-2-2 Video OUT Test

Table 4-8 Video OUT Test

Step	Task	Expected Result(s)
1	Activate a CineLoop or Freeze a scanned image.	
2	Connect the monitor to the composite VIDEO OUT 1 connector and check the image.	The image is displayed correctly.
3	Connect the monitor to the composite VIDEO OUT 2 connector and check the image.	The image is displayed correctly.
4	Connect the monitor to the composite VIDEO B/W connector and check the image. See B/W Printer Tests , below.	The image is displayed correctly.
5	Connect the monitor to the Color Printer RGB connectors and check the image. See Color Printer Tests , below.	The image is displayed correctly.

4-3-2-3 B/W Printer Tests

Table 4-9 B/W Printer Test

Step	Task	Expected Result(s)
1	Scan a phantom or suitable interface in 2D-Mode.	
2	Press the Freeze button.	
3	Press the Print B button.	Evaluate the print quality. Adjust the <i>brightness</i> and/or <i>contrast</i> of the B/W printer, if required.

4-3-2-4 Color Printer Tests

Table 4-10 Color Printer Test

Step	Task	Expected Result(s)
1	Scan a blood vessels in 2D-Mode or a phantom simulating a similar CFM effect, then activate CFM to see color.	
2	Press the Freeze button.	
3	Press the Print A button.	Evaluate the color print quality. Adjust the <i>brightness</i> and/or <i>contrast</i> of the Color printer, if required.

4-3-3 Mechanical Functions

4-3-3-1 Console Movement Test

Table 4-11 Console Movement Test

Step	Task	Expected Result(s)
1	Pull the front handle located under the control console and lift the console to its maximum height.	Ensure that you do not apply too much force to move the console and that the console movement is smooth.
2	Pull the front handle located under the control console and push the console to its minimum height.	Ensure that you do not apply too much force to move the console and that the console movement is smooth.

4-3-3-2 Brakes Function Test

Table 4-12 Brakes Function Test

Step	Task	Expected Result(s)
1	Push the brake pedal to its <i>center</i> position. Push and pull the unit right, left, backwards and forwards.	Ensure that the wheels move freely in all directions. Check the wheels for wear and tear, and replace if necessary.
2	Push the brake pedal to its <i>left</i> position (parking). Push and pull the unit right, left, backwards and forwards.	Ensure that the wheels are locked and there is no movement in any direction.
3	Push the brake pedal to its <i>right</i> position (arrows). Push and pull the unit right, left, backwards and forwards.	Ensure that the front wheels are locked for right and left movement <i>only</i> , but can move freely backwards and forwards.

4-3-4 Back End Processor Tests

4-3-4-1 Internal ECG Test

Table 4-13 Internal ECG Test

Step	Task	Expected Result(s)
1	Connect the internal ECG input to an ECG simulator or suitable substitute, using the cable set and electrode pads.	
2	Perform the ECG diagnostic test, as described in the ECG/Phono Diagnostic Test on page 7 - 71.	Verify that a single clear QRS signal is displayed.

4-3-4-2 Phono Test (optional)

Table 4-14 Phono Test

Step	Task	Expected Result(s)
1	Connect the microphone to the microphone input on the ECG Board. Note that the special Medical Microphone is required.	
2	Perform the Phono diagnostic test, as described in the ECG/Phono Diagnostic Test on page 7 - 71 Use your finger to click (tap) the microphone.	Verify that the waveform on the screen corresponds to the microphone clicks.

4-3-4-3 Magneto Optical Drive (MOD) Test

Table 4-15 MOD Test

Step	Task	Expected Result(s)
1	Restart the system performing a full shutdown and bootup, as described in the Power ON/OFF and Boot-up Tests on page 4 - 2.	During the boot-up process, verify that the messages SCSI Adaptor Installation 2271149-2INS and MO are displayed.
2	Insert a new MO Media Sony EDM-2300B (2.3G) into the MOD.	
3	Press Ctrl+F11 (or Alt+D) on the keyboard and select <Back End>, <Media Driver> and <MO>, as appropriate.	The UtilMediaApp dialog box is displayed.
4	Select the IsMediaAcces button.	The message Media in drive G is accessible is displayed.
5	Select the EjectMO button.	The message Media is outside is displayed. Check that the media has actually been ejected.
6	Select the LoadMO button.	The message Media is inside is displayed. Check that the media is actually inside.
7	Select the Format button.	The message Media in drive G was formatted successfully is displayed.
8	Select the GetVolInfo button.	The message Media in drive G has following properties: Media Label = MY_LABEL, Media File-System Name = FAT is displayed.
9	Select the Get BTPsector button.	The message The Bytes Per Sector value of media in drive G is 512 is displayed.
10	Select the SetVolLabel1 button.	The message Media Label set to TEST_LABEL1 is displayed.
11	Select the GetVolInfo button.	The message Media in drive G has following properties: Media Label = TEST_LABEL, Media File-System Name = FAT is displayed.
12	Select the Exit button and close the Diagnostic Application.	
13	Press the Archive button on the keyboard.	The <i>Patient List</i> window is displayed.
14	Press the Utilities button on the soft menu.	The <i>General Status</i> window is displayed.
15	Press the Removable Media Utility button.	The <i>Utility</i> window is displayed, showing the message: Free space on Media: 1096 MB.
16	Type the new label (for example, "Side1"), then select the Format button. Confirm "YES" to the warning message.	The message Current Media Name is:SIDE1. Media was formatted successfully is displayed. MO Label: SIDE1, MO STATUS: MOUNTED
17	Select the Eject button.	The message Media Ejected is displayed. MO STATUS: Ejected.
18	Select the OK button to exit the utility.	

4-3-4-4 CD Writer Test

Table 4-16 CD Writer Test

Step	Task	Expected Result(s)
1	Insert the new recordable CD X16 in the CDR drive.	
2	Press Ctrl+F11 (or Alt+D) on the keyboard and select <Back End>, <Media Driver> and <CDR> as appropriate.	UtilMO_CDR_App is displayed.
3	Select the IsMediaAcces button and <OK>.	The message Media in drive H is accessible is displayed.
4	Select the Eject button. Respond <No> to the <i>Finalize Media? Yes/No</i> message.	The message Media is outside is displayed. Check that media has actually been ejected and select <OK>.
5	Press the Load button and respond <OK> to the message.	The message Media is inside is displayed. Check that media is really inside.
6	Press the Format button and respond <OK> to the message.	The message Media in drive H was formatted successfully is displayed.
7	Press the GetVolInfo button and respond <OK> to the message.	The message Media in drive H has following properties: Media Label = Media File-System Name = CDUDF is displayed.
8	Press the Get BTPsector button and respond <OK> to the message.	The message The Bytes Per Sector value of Media in Drive H is 2048 is displayed.
9	Press the SetVolLabel2 button and respond <OK> to the message.	The message Media Label set to TEST_LABEL2 is displayed.
10	Press the GetVolInfo button and respond <OK> to the message.	The message Media in drive H has following properties: Media Label = TEST_LABEL2 Media File-System Name = CDUDF is displayed.
11	Press the FlushVol button and respond <OK> to the message.	The message The cached data is flushed to the volume in drive H is displayed.
12	Press the Exit button and close the Diagnostic Application.	
13	Press the Archive button on the keyboard.	The <i>Patient List</i> window is displayed.
14	Press the Utilities button on the soft menu.	The <i>General Status</i> window is displayed.
15	Press the Removable Media Utility button and select MEDIA: CDRW.	The <i>Utility</i> window is displayed showing the message Free space on Media: 665MB". MEDIA LABEL: TEST_LABEL2. Media status: MOUNTED.
16	Press the Eject button and respond <No> to the Do you want to Close Media for external use message.	MEDIA STATUS: Ejected.
17	Press the OK button to exit the utility.	

4-3-4-5 Plug and Scan Test

Table 4-17 Plug and Scan Test

	Task	Expected Result(s)
1	Press the On/Off button on the control console for no more than 3 seconds.	The system enters <i>Standby</i> mode.
2	Turn OFF the system's circuit breaker.	The system remains in <i>Standby</i> mode, indicated by the blinking On/Off button LED.
3	Turn ON the system's circuit breaker. Press the On/Off Button.	The system returns quickly to the <i>Power-ON</i> state -less than 30 seconds.
4	Turn OFF the system's circuit breaker. Turn ON the system's circuit breaker after entering to <i>Standby</i> mode.	The system enters <i>Standby</i> mode and stays in this mode. The On/Off button LED is blinking.
5	Turn OFF the system's circuit breaker. Press the On/Off button.	The system enters the <i>Power-OFF</i> state. The On/Off button LED is OFF.

Section 4-4 Image Testing: 2D/M/CFM/Doppler

NOTE: To perform these tests thoroughly, it is recommended to use three types of soft tissue phantoms: RMI 403GS, RMI 404G and RMI 1425A, or an equivalent surface that can simulate the same soft tissue effects.

4-4-1 3S Probe Image Quality Tests

4-4-1-1 2D Noise Uniformity Test

Table 4-18 2D Noise Uniformity Test (3S)

Step	Task	Expected Result(s)
1	With a 3S probe in the air, select a Cardiac preset.	
2	Set the following parameters: <ul style="list-style-type: none"> • 2D Gain = 50 • Depth = 7cm • Dynamic Range = 80dB 	Ensure that there are no white circular lines or other patterns in the noise.

4-4-1-2 2D Performance Test

Table 4-19 2D Performance Test (3S)

Step	Task	Expected Result(s)
1	Use the Standard Imaging Phantom RMI403GS.	
2	Select a Cardiac preset.	
3	Set the TGC so that the image is uniform.	

4-4-1-3 2D Penetration Test

Table 4-20 2D Noise Penetration Test (3S)

Step	Task	Expected Result(s)
1	Use the Standard Imaging Phantom RMI403GS.	
2	Select a cardiac preset.	
3	Set the following parameters, and scan the phantom at position (3): <ul style="list-style-type: none"> • Gain: 37 • Power: 0 dB • Depth: 20cm • Focus: Max depth • Dynamic Range: 65dB 	
4	Record the maximum depth at which tissue can be differentiated from the noise.	The depth should be greater than 18cm.

4-4-1-4 CFM Noise Floor Test

Table 4-21 CFM Noise Floor Test (3S)

Step	Task	Expected Result(s)
1	With the 3S probe in the air, select a Cardiac preset and activate CFM.	
2	Set the CFM ROI to its maximum size.	
3	Set the following CFM parameters: <ul style="list-style-type: none"> • Range: 20cm • Tissue Priority: 0 	
4	Set the Active Gain until a few color noise dots appear in the ROI.	The Active Gain should be between 61 and 65.

4-4-1-5 CFM Stationary Noise Test

Table 4-22 CFM Stationary Noise Test (3S)

Step	Task	Expected Result(s)
1	Use the vertical nail area in the Electronic Flow Phantom RMI1425A.	
2	Place the 3S probe above the vertical nails line (position 1).	
3	Select a Cardiac preset and activate CFM.	
4	Set the following CFM parameters: <ul style="list-style-type: none"> Gain: Max possible without color noise Tissue Priority: 0 Flash: 0 	Ensure that the color does not appear constantly on the white nail.

4-4-1-6 Probe Operation Check (Alignment and Sensitivity) Test

Table 4-23 Probe Operation Check (Alignment and Sensitivity) Test (3S)

Step	Task	Expected Result(s)
1	Use the Electronic Flow Phantom RMI1425A.	
2	Set the Phantom settings as follows: <ul style="list-style-type: none"> Preset: 3 Mode: Steady 	

4-4-1-7 CFM Operation Tests

Table 4-24 CFM Operation Tests (3S)

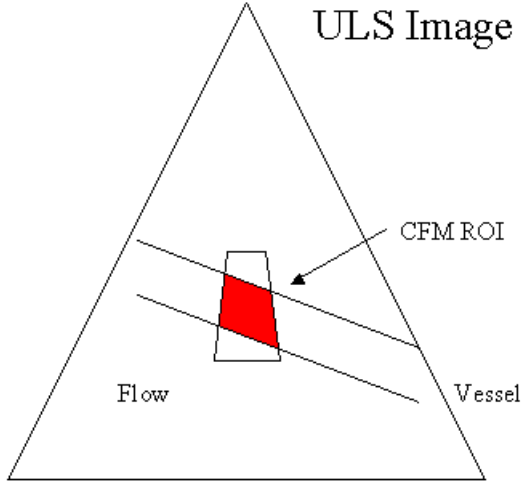
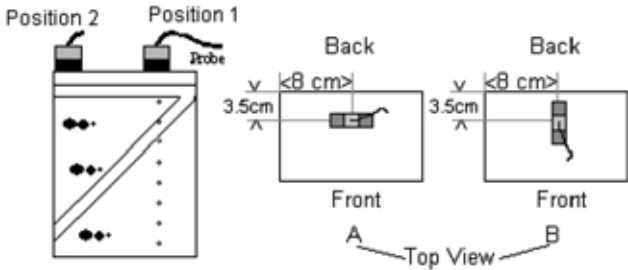
Step	Task	Expected Result(s)
1	Select a Cardiac preset and set the 2D Gain to 40.	
2	Activate CFM and set the following CFM parameters: <ul style="list-style-type: none"> • Gain: Max possible without color noise • Frame Rate:2 • LVR: MIN setting 	 <p>The diagram shows a triangular ULS Image. Inside, a vessel is outlined. A red-shaded area within the vessel is labeled 'CFM ROI'. An arrow labeled 'Flow' points from the bottom-left towards the top-right of the vessel. Labels 'ULS Image' and 'Vessel' are also present.</p>
	CFM Artifacts Test	 <p>The diagram illustrates the setup for the CFM Artifacts Test. It shows a 3S probe in two positions: Position 1 and Position 2. Below, two top views (A and B) are shown. Top View A shows the probe at a 3.5cm distance from a vessel, with a diameter of <math>\leq 8\text{ cm}></math>. Top View B shows the probe rotated 90 degrees, also at a 3.5cm distance from a vessel with a diameter of <math>\leq 8\text{ cm}></math>.</p>
3	Place the 3S probe on the RMI1425A Phantom (top view A).	Ensure there are no flash strikes or other color artifacts.
	CFM Alignment Test	
4	Rotate the probe 90 degrees (top view B) to see a circular cross-section of the vessel.	Ensure that the color exactly overlaps the vessel.

4-4-1-8 Color M Operation Tests

Table 4-25 Color M Operation Tests (3S)

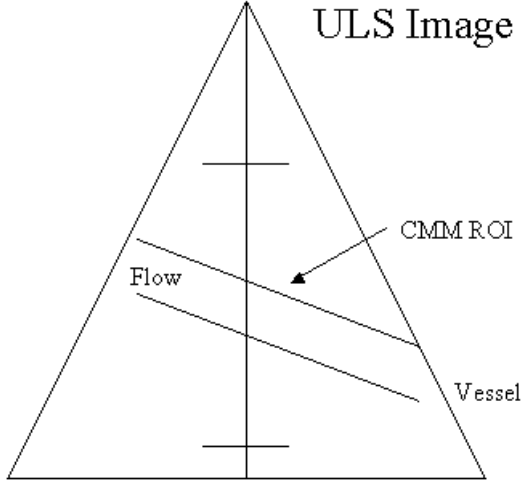
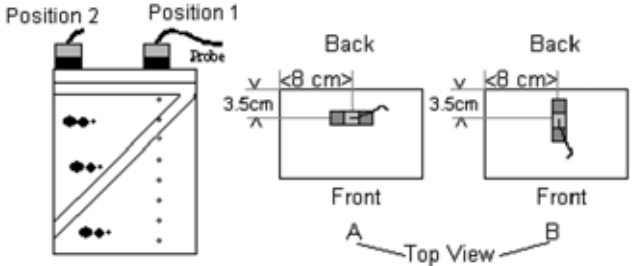
Step	Task	Expected Result(s)
1	Select a Cardiac preset and set the following 2D parameters: <ul style="list-style-type: none"> • 2D Gain: 50 • 2D Dynamic Range: 60 • 2D Reject: 10% 	 <p>ULS Image</p> <p>CMM ROI</p> <p>Flow</p> <p>Vessel</p>
2	Activate CFM and set the CFM Gain to the maximum possible without color noise.	
3	Activate M-Mode.	Color M-Mode (CMM) is activated.
4	Place the 3S probe on the RMI1425A Phantom (top view A) and position the M-Marker across the vessel.	 <p>Position 2</p> <p>Position 1</p> <p>Probe</p> <p>Back</p> <p>Back</p> <p>3.5cm</p> <p>3.5cm</p> <p>Front</p> <p>Front</p> <p>A</p> <p>B</p> <p>Top View</p> <p>Ensure that you see a continuous orange line. Note that the line does not need to look smooth. Ensure there are no strikes or other artifacts.</p>

4-4-1-9 PW Operation Test

Table 4-26 PW Operation Tests (3S)

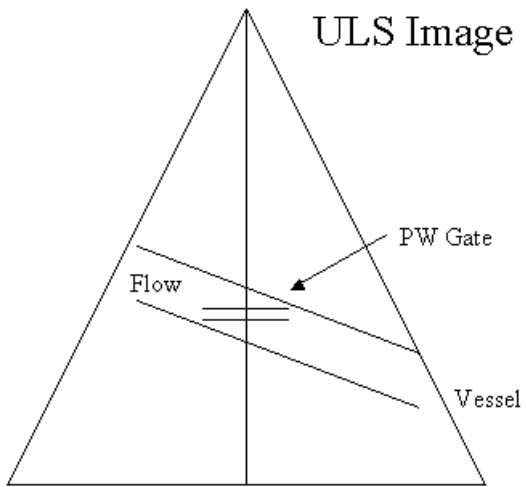
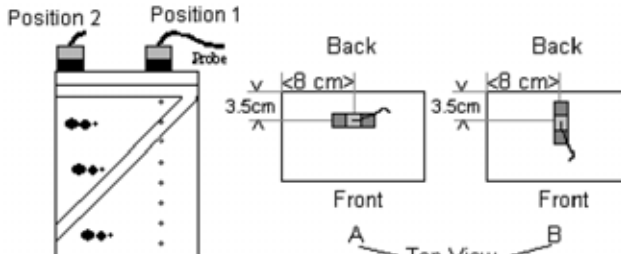
Step	Task	Expected Result(s)
1	Select a Cardiac preset and set the 2D Gain to 40.	
2	Activate PW Mode and set the following PW parameters: <ul style="list-style-type: none"> Gain: 70 SV: 3mm 	 <p>The diagram shows a triangular ULS Image. A vertical line represents the vessel. A horizontal line across it is labeled 'PW Gate'. An arrow pointing to the right is labeled 'Flow'. The vessel is labeled 'Vessel'.</p>
	PW Artifacts Test	
3	Place the 3S probe on the RMI1425A Phantom (top view A).	 <p>The diagram shows a 3S probe on a phantom. Two positions are marked: 'Position 1' and 'Position 2'. Two top views are shown: 'A' and 'B'. Dimensions are given as 3.5cm and <math>\lt; 8 \text{ cm} ></math>.</p>
4	Place the sample volume in the center of the vessel.	Ensure that the flow looks clear, the noise area is dark and that there are no flash strikes or other artifacts.
5	Move the sample volume to different locations along the vessel.	Ensure that the flow looks clear, the noise area is dark and that there are no flash strikes or other artifacts.
	PW HPRF Artifacts Test	
6	Increase the velocity range to MAX.	
7	Place the 3S probe on the RMI1425A Phantom (top view A).	
8	Place the sample volume in the center of the vessel.	Ensure that the flow looks clear, the noise area is dark and that there are no flash strikes or other artifacts.
9	Move the sample volume to different locations along the vessel.	Ensure that the flow looks clear, the noise area is dark and that there are no flash strikes or other artifacts.

4-4-1-10 CW Operation Tests

Table 4-27 CW Operation Tests (3S)

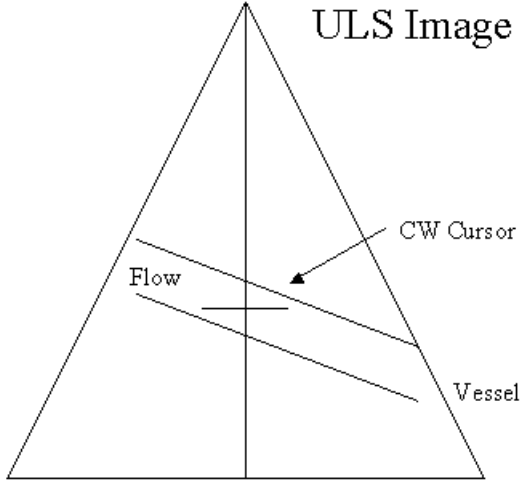
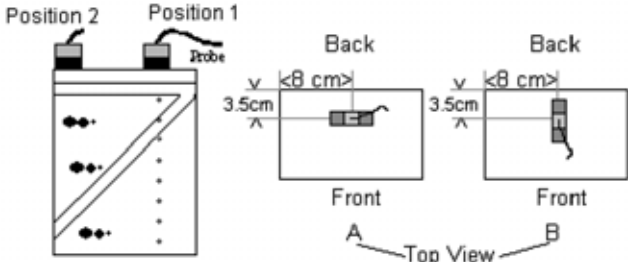
Step	Task	Expected Result(s)
1	Select a Cardiac preset and set the 2D Gain to 45.	
2	Activate CW Mode and set the following CW parameters: <ul style="list-style-type: none"> • CW Gain: 70 • Velocity Scale: 3.0m/sec 	 <p style="text-align: right;">ULS Image</p>
CW Artifacts Test		
3	Place the 3S probe on the RMI1425A Phantom (top view A).	
4	Place the CW cursor in the center of the vessel.	Ensure that the flow looks clear, the noise area is dark and that there are no flash strikes or other artifacts.
5	Move the CW cursor to different locations along the vessel.	Ensure that the flow looks clear, the noise area is dark and that there are no flash strikes or other artifacts.
CW High Velocity Artifacts Test		
6	Increase the Velocity Scale to 8.6m/s (max).	
7	Place the 3S probe on the Phantom (top view A).	
8	Place the CW cursor in the center of the vessel.	Ensure that the flow looks clear, the noise area is dark and that there are no flash strikes or other artifacts.
9	Move the CW cursor to different locations along the vessel.	Ensure that the flow looks clear, the noise area is dark and that there are no flash strikes or other artifacts.

4-4-1-11 CW Noise Test

Table 4-28 CW Noise Test (3S)

Step	Task	Expected Result(s)
1	With a 3S probe in the air, select a Cardiac preset and activate CW-Mode.	
2	Set the Audio Gain to the minimal level at which the audio noise is just visible.	Check that the Doppler audio and display noise are homogenous and constant.
3	Move the cursor angle multiple times from one half of the screen to the other.	Check that the noise level does not increase after the cursor angle is changed.

4-4-2 7S Probe Image Quality Tests

4-4-2-1 2D Center Noise Test

NOTE: This test should be performed in a dark room.

Table 4-29 2D Noise Center Test (7S)

Step	Task	Expected Result(s)
1	With a 7S probe in the air, select a Pediatrics preset.	
2	Reduce the 2D Gain until the background noise disappears.	
3	Increase the Gain until "flashlight" noise is displayed in the center of the screen, as shown opposite, and write down the Gain value.	
4	Increase the Gain until the background noise is displayed, and write down the Gain value.	Ensure that the Gain difference is not higher than 2.

4-4-3 C358 Curved Probe Image Quality Tests

4-4-3-1 2D Artifacts Test

Table 4-30 2D Artifacts Test (C358)

Step	Task	Expected Result(s)
1	Use the Standard Imaging Phantom RMI403GS.	
2	Set the following parameters: <ul style="list-style-type: none"> • Depth: 22cm • Frame Rate: 2 (single focus) • Focus Location: 12cm 	
3		Look for artifacts in the image.

4-4-3-2 CFM Artifacts Test

Table 4-31 CFM Artifacts Test (C358)

Step	Task	Expected Result(s)
1	Use the Electronic Flow Phantom RMI1425A. Select the Abdomen preset from the Abdomen preset options, and set the 2D Gain to 45.	
2	Select CFM and set the following CFM parameters: <ul style="list-style-type: none"> • Gain: Maximum possible without color noise. • Frame Rate: 2 • LVR: Minimum setting 	
3	Place the C358 probe on the Phantom (top view A).	Ensure that there are no flash strikes or other color artifacts.

4-4-3-3 PW Operation Tests

Table 4-32 PW Operation Tests (C358)

Step	Task	Expected Result(s)
1	Select the Abdomen preset from the Abdomen preset options, and set the 2D Gain to 45.	
2	Activate PW Mode and set the following PW parameters: <ul style="list-style-type: none"> • Gain: 70 • SV: 3mm 	<p>The diagram shows a triangular ULS (Ultrasound Line Scan) image. A vertical line represents the vessel. A horizontal line across it is labeled 'PW Gate'. An arrow pointing to the right is labeled 'Flow'. The vessel is labeled 'Vessel'.</p>
PW Artifacts Test		
3	Place the C358 probe on the RMI1425A Phantom (top view A).	<p>The diagram shows a top view of a phantom with two probe positions, Position 1 and Position 2. Position 1 is at the top center, and Position 2 is at the top left. Below are two front views of the phantom, labeled A and B. Both show a probe placed in the center of a vessel. The vessel width is labeled as <math>\leq 8 \text{ cm}></math> and the probe depth is labeled as 3.5cm.</p>
4	Place the sample volume in the center of the vessel.	Ensure that the flow looks clear, the noise area is dark and that there are no flash strikes or other artifacts.
5	Move the sample volume to different locations along the vessel.	Ensure that the flow looks clear, the noise area is dark and that there are no flash strikes or other artifacts.
PW HPRF Artifacts Test		
6	Increase the velocity range to MAX.	
7	Place the C358 probe on the Phantom (top view A).	
8	Place the sample volume in the center of the vessel.	Ensure that the flow looks clear, the noise area is dark and that there are no flash strikes or other artifacts.
9	Move the sample volume to different locations along the vessel.	Ensure that the flow looks clear, the noise area is dark and that there are no flash strikes or other artifacts.

4-4-4 739L Probe Image Quality Tests

4-4-4-1 2D Noise Uniformity Test

Table 4-33 2D Noise Uniformity Test (739L)

Step	Task	Expected Result(s)
1	With a 739L probe in the air, select the Carotid preset from the Vascular preset options.	
2	Set the following parameters: <ul style="list-style-type: none"> • 2D Gain = Max • Depth = 2cm • Gain Sliders= Max 	
		Up to 5mm of white carpet noise should be displayed, as shown in the left figure above. Ensure that there are no white lines along the image (down to 2cm) or other artifacts like those shown in the figure on the right, above.

4-4-4-2 2D Performance Test

Table 4-34 2D Performance Test (739L)

Step	Task	Expected Result(s)
1	Use the Standard Superficial Phantom RMI404G.	
2	Select the Carotid preset from the Vascular preset options.	
3	Set the following parameters: <ul style="list-style-type: none"> • Depth: 10cm • Frame Rate: 2 (single focus) • Focus Location: 6cm 	

4-4-4-3 CFM Stationary Noise Test

Table 4-35 CFM Stationary Noise Test (739L)

Step	Task	Expected Result(s)
1	Use the vertical nail area in the Electronic Flow Phantom RMI1425A.	
2	Place the 739L probe above the vertical nails line (position 1).	
3	Select a Cardiac preset and activate CFM.	
4	Set the following CFM parameters: <ul style="list-style-type: none"> • Gain: Max possible without color noise • Tissue Priority: 0 • Flash: 0 	Ensure that the color does not appear constantly on the white nail.

4-4-4-4 Probe Operation Check (Alignment & Sensitivity)

Table 4-36 Probe Operation Check (Alignment and Sensitivity) Test (739L)

Step	Task	Expected Result(s)
1	Use the Electronic Flow Phantom RMI1425A.	
2	Set the Phantom settings as follows: <ul style="list-style-type: none"> • Preset: 3 • Mode: Steady 	

4-4-4-5 CFM Operation Tests

Table 4-37 CFM Operation Tests (739L)

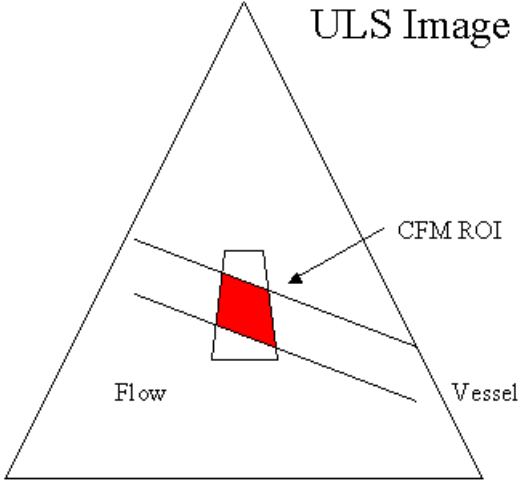
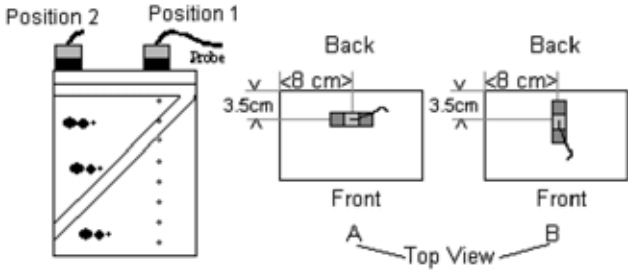
Step	Task	Expected Result(s)
1	Select a Cardiac preset and set the 2D Gain to 40.	
2	Activate CFM and set the following CFM parameters: <ul style="list-style-type: none"> • Gain: Max possible without color noise • Frame Rate:2 • LVR: MIN setting 	 <p>The diagram shows a triangular field of view labeled 'ULS Image'. Inside the triangle, a red trapezoidal area is labeled 'CFM ROI'. Below the ROI, the word 'Flow' is written. To the right of the ROI, the word 'Vessel' is written. Arrows point from the labels to the corresponding parts of the diagram.</p>
	<p>CFM Artifacts Test</p>	 <p>The diagram illustrates the setup for the CFM Artifacts Test. On the left, a probe is shown in two positions: 'Position 1' and 'Position 2'. To the right, two top views of the probe are shown, labeled 'A' and 'B'. Each top view shows a rectangular area with a 'Back' side and a 'Front' side. The distance from the center of the probe to the back edge is labeled as $\frac{y}{x} < \theta \text{ cm} >$. The distance from the center to the front edge is labeled as 3.5cm.</p>
3	Place the 739L probe on the RMI1425A Phantom (top view A).	Ensure there are no flash strikes or other color artifacts.

4-4-4-6 PW Operation Tests

Table 4-38 PW Operation Tests (739L)

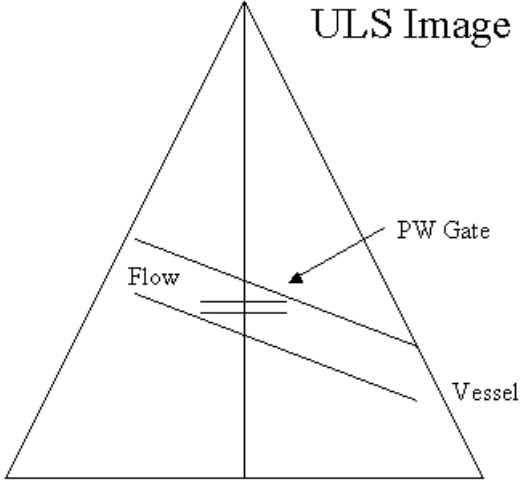
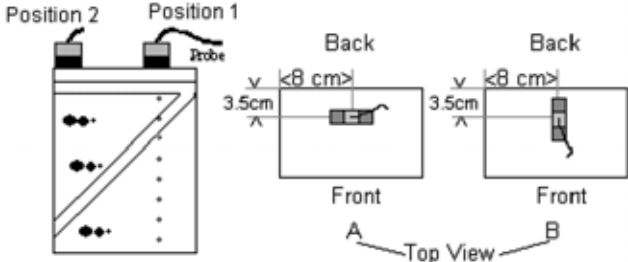
Step	Task	Expected Result(s)
1	Select the Abdomen preset from the Abdomen preset options, and set the 2D Gain to 90.	
2	Activate PW Mode and set the following PW parameters: <ul style="list-style-type: none"> • Gain: 70 • SV: 3mm 	
PW Artifacts Test		
3	Place the 739L probe on the RMI1425A Phantom (top view A).	
4	Place the sample volume in the center of the vessel.	Ensure that the flow looks clear, the noise area is dark and that there are no flash strikes or other artifacts.
5	Move the sample volume to different locations along the vessel.	Ensure that the flow looks clear, the noise area is dark and that there are no flash strikes or other artifacts.
PW HPRF Artifacts Test		
6	Increase the velocity range to MAX.	
7	Place the 739L probe on the Phantom (top view A).	
8	Place the sample volume in the center of the vessel.	Ensure that the flow looks clear, the noise area is dark and that there are no flash strikes or other artifacts.
9	Move the sample volume to different locations along the vessel.	Ensure that the flow looks clear, the noise area is dark and that there are no flash strikes or other artifacts.

4-4-5 Probe 10S Image Quality Tests

4-4-5-1 2D Center Noise Test

NOTE: This test should be performed in a dark room.

Table 4-39 2D Noise Center Test (10S)

Step	Task	Expected Result(s)
1	Perform this test with a 10S probe in the air for all the probe ports.	
2	Reduce the 2D Gain until the background noise disappears.	
3	Increase the Gain until "flashlight" noise is displayed in the center of the screen, as shown opposite, and write down the Gain value.	
4	Increase the Gain until background noise is displayed, and write down the Gain value.	Ensure that the Gain difference is not higher than 4.

4-4-5-2 Doppler Artifacts Test

Table 4-40 Doppler Artifacts Test (10S)

Step	Task	Expected Result(s)
1	Perform this test in PW and CW Modes.	
2	Find a suitable surface that can simulate a signal on the neck (for example, RMI1425A) and look for artifacts in all possible frequencies.	No artifacts are detected.

4-4-6 2D (Pencil) Probe Image Quality Test

4-4-6-1 Image Quality Test

Table 4-41 Image Quality Test (2D Pencil Probe)

Step	Task	Expected Result(s)
1	Activate CW Mode.	
2	Find a signal in the neck or other suitable surface.	
	Find a suitable surface that can simulate a signal on the neck (for example, RMI1425A) and look for artifacts while searching for a signal.	No artifacts are detected.

Section 4-5 System Turnover Checklist

Before returning the Vivid™ 3 ultrasound scanner to regular operational use, the System Configuration settings should be checked. In 2D-Mode, press **Config** on the keyboard and check the settings in accordance with those listed in [Table 4-42](#) below, referring also to [Figure 4-1](#) through [Figure 4-6](#).

NOTE: *The figures in this section ([Figure 4-1](#) through [Figure 4-6](#)) show example configurations and should be used for reference only, as each site has its own specific settings.*

4-5-1 Software Configuration Checks

Table 4-42 Software Configuration Checklist

Step	Task	Check
1	Check the date and time settings.	
2	Check the language settings.	
3	Ensure that all of the options are configured correctly.	
4	Ensure that the hospital details are configured correctly.	
5	Ensure that the VCR and ECG are configured as required for the specific site and country.	
6	Ensure that the measurement units are configured as required for the specific site and country.	
7	Ensure that the connectivity network settings have not been modified and are configured as required for the specific site.	



Figure 4-1 System Tab Configuration - Example

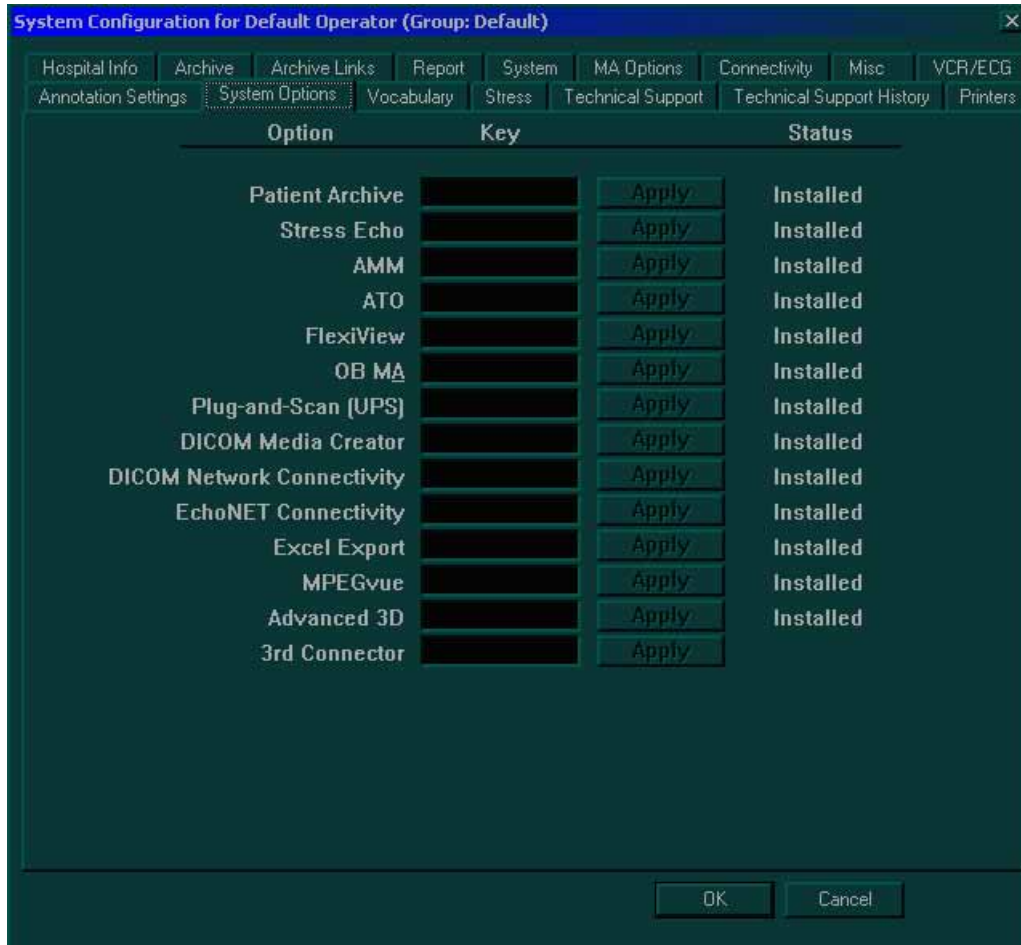

Figure 4-2 System Options Tab Configuration - Example

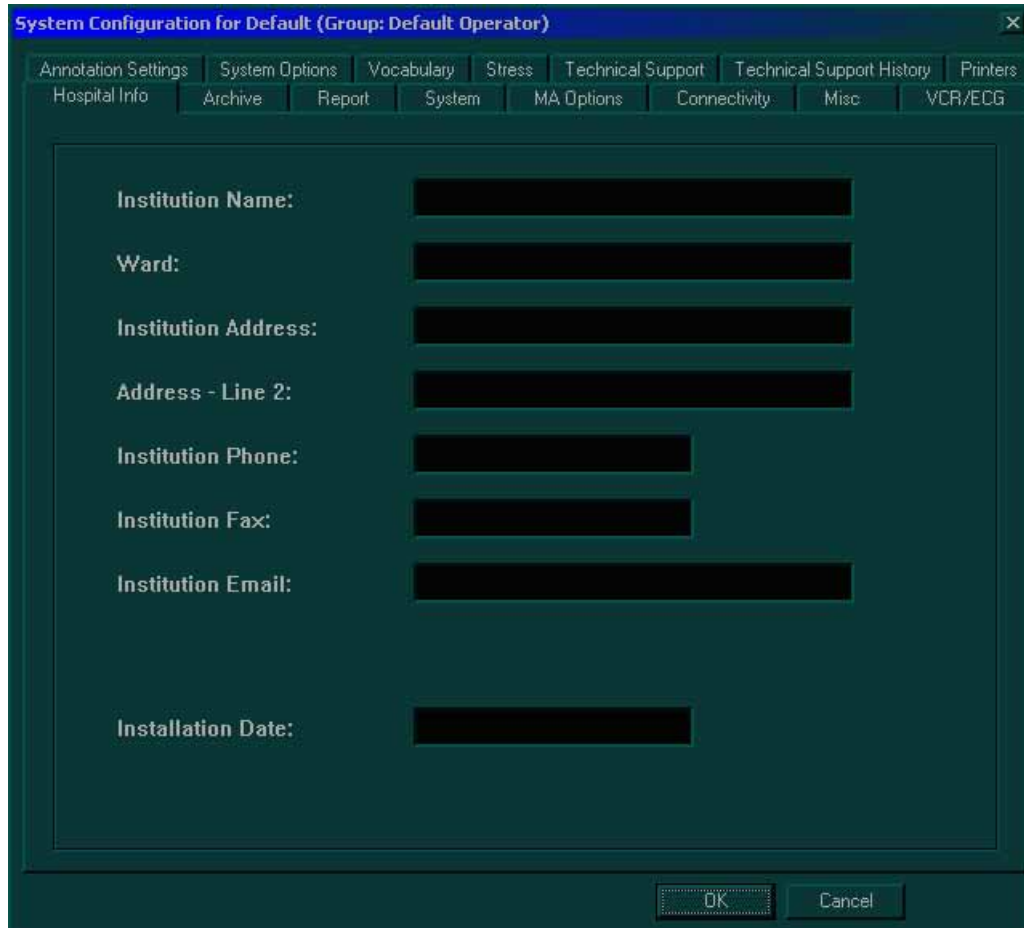

Figure 4-3 Hospital Info Tab Configuration - Example

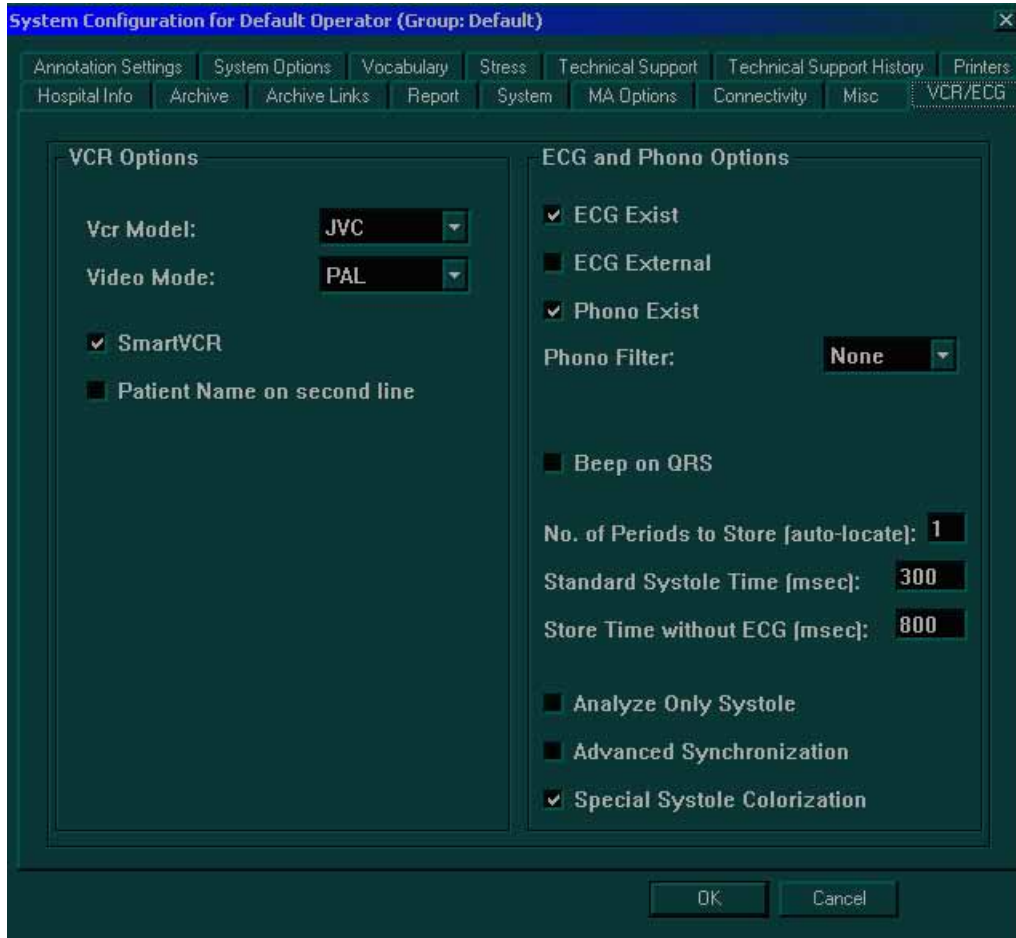

Figure 4-4 VCR/ECG Tab Configuration - Example

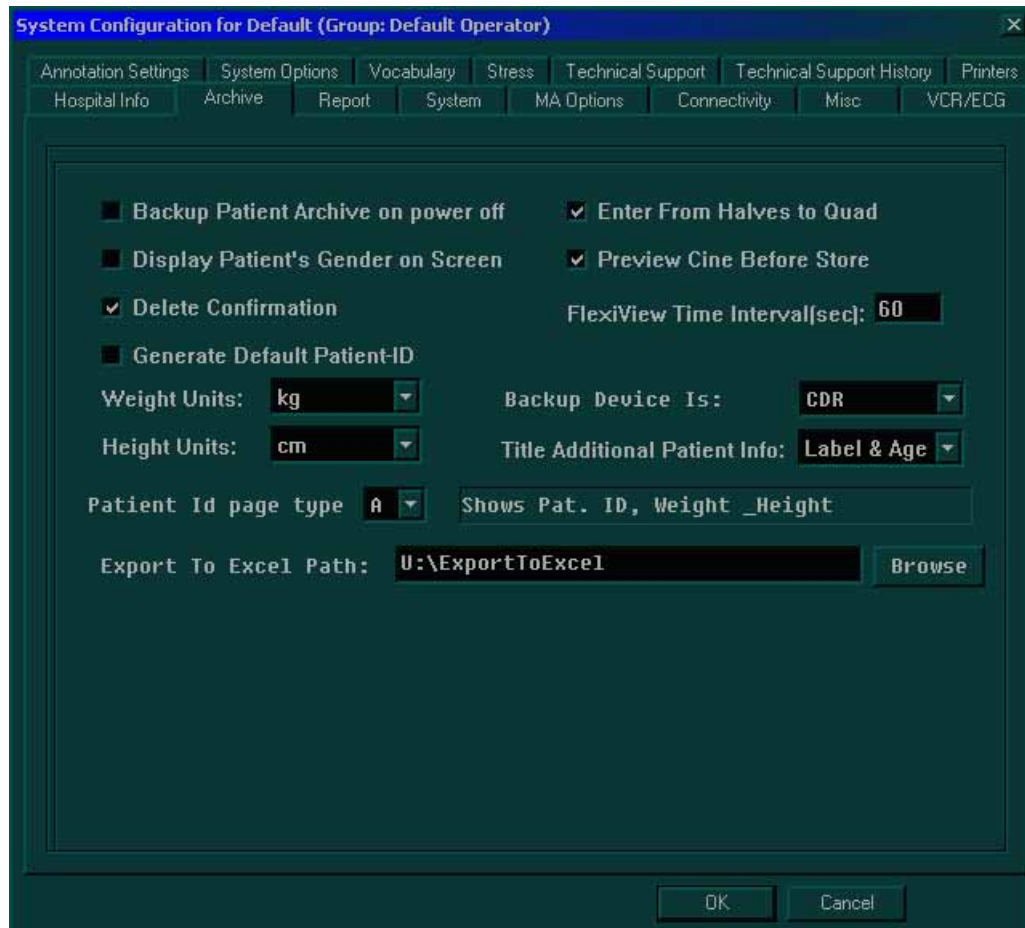

Figure 4-5 Archive Tab Configuration - Example

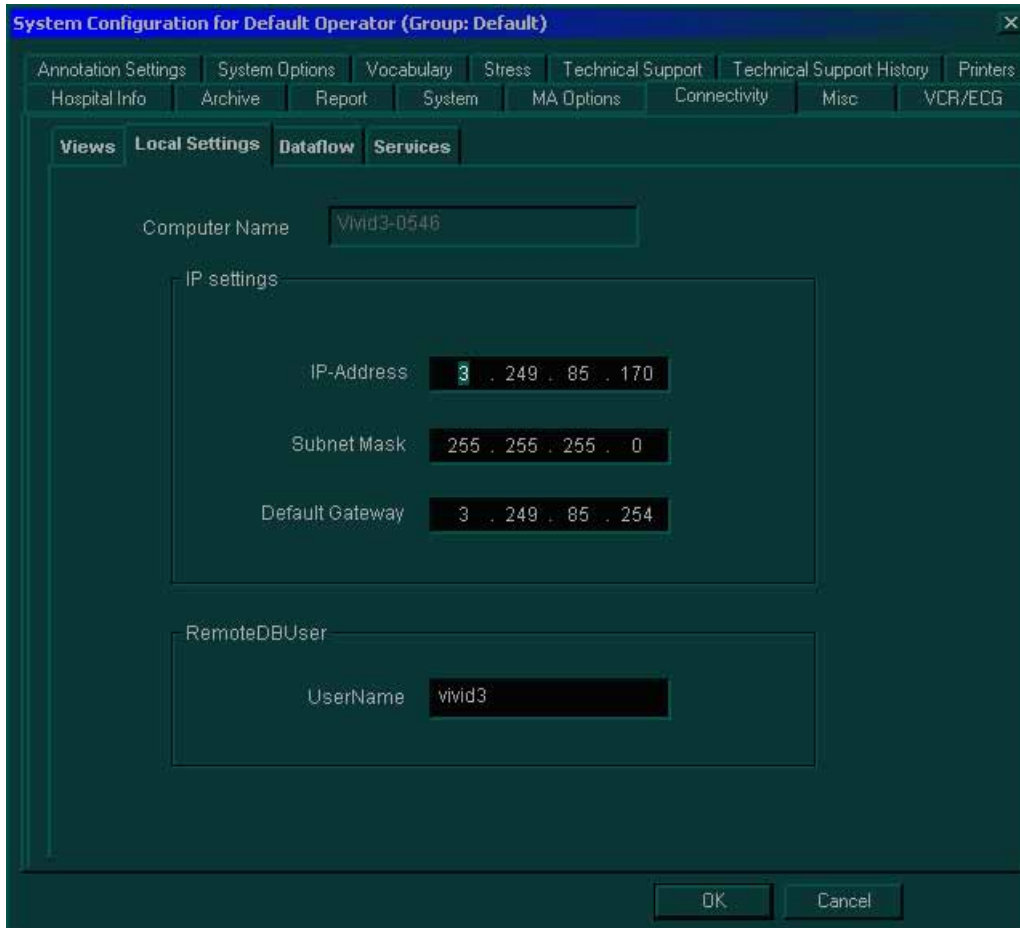

Figure 4-6 Connectivity Local Settings Tab Configuration - Example

Table 4-1: Vivid™ 3 Site Log (Continued)

Date	Service Person	Problem	Comments

Chapter 5

Components and Function (Theory)

Section 5-1 Overview

5-1-1 Purpose of Chapter 5

This chapter contains block diagrams and functional explanations of the Vivid™ 3 electronic circuits.

Table 5-1 Contents in Chapter 5

Section	Description	Page Number
5-1	Overview	5-1
5-2	General Information	5-2
5-3	Block Diagrams	5-3
5-4	Front End	5-7
5-5	Back End Processor	5-26
5-6	External Peripherals	5-41
5-7	Vivid™ 3 Power Distribution	5-42
5-8	Front End Cooling System	5-49
5-9	Common Service Platform	5-50

Section 5-2 General Information

The Vivid™ 3 is a phased, linear array ultrasound imaging scanner. The system is versatile and, depending upon the software, can be used for various applications, such as:

- 2D Grey Scale and 2D Color Flow Imaging
- M-Mode Grey Scale Imaging
- Color M-Mode
- Doppler
- A number of combinations of the above
- 3D Post-processing

A Physio module is incorporated in the Backend Processor (BEP) to provide ECG signals to synchronize cardiac ultrasound image acquisition. Additionally, other analog inputs (e.g. ECG, phono) from devices such as treadmills, are processed.

Vivid™ 3 is a digital beam forming system which can handle up to 192 element linear probes by use of multiplexing.

Signal flow travels from the Probe Connector Panel, to the Front End (FE) Electronics, to the BEP, and finally is displayed on the monitor and peripherals.

System configuration is stored on a hard disk Hasp plug and all necessary software is loaded from the hard disk on power-up.

- The user initiates system operation via the Control Console which contains a keyboard, control panel, and TGC.
- Vivid™ 3 internal electronics are divided into two card cages:
 - Front End (FE) Processor - sometimes referred to as “Card Cage” in this manual.
 - Backend Processor (BEP)
- Interconnecting signals from the FE, BEP, Control Console, Monitor and Power distribution subsystems are routed via cables.

The main functional blocks in Vivid™ 3 are:

- Front End (FE) Processor
- Back End Processor (BEP)
- Control Console
- Power Distribution
- Peripherals
- Modem

Section 5-3 Block Diagrams

5-3-1 System Block Diagrams

The following system block diagrams are included in this section:

- [System Block Diagram - Vivid™ 3 BT03 - RFI Configuration](#) (see below).
- [System Block Diagram - Vivid™ 3 BT03 - RFT Configuration](#) on page 5 - 4
- [System Cabling Diagram - Vivid™ 3 BT03 - RFI Configuration](#) on page 5 - 5.
- [System Cabling Diagram - Vivid™ 3 BT03 - RFI Configuration](#) on page 5 - 5.

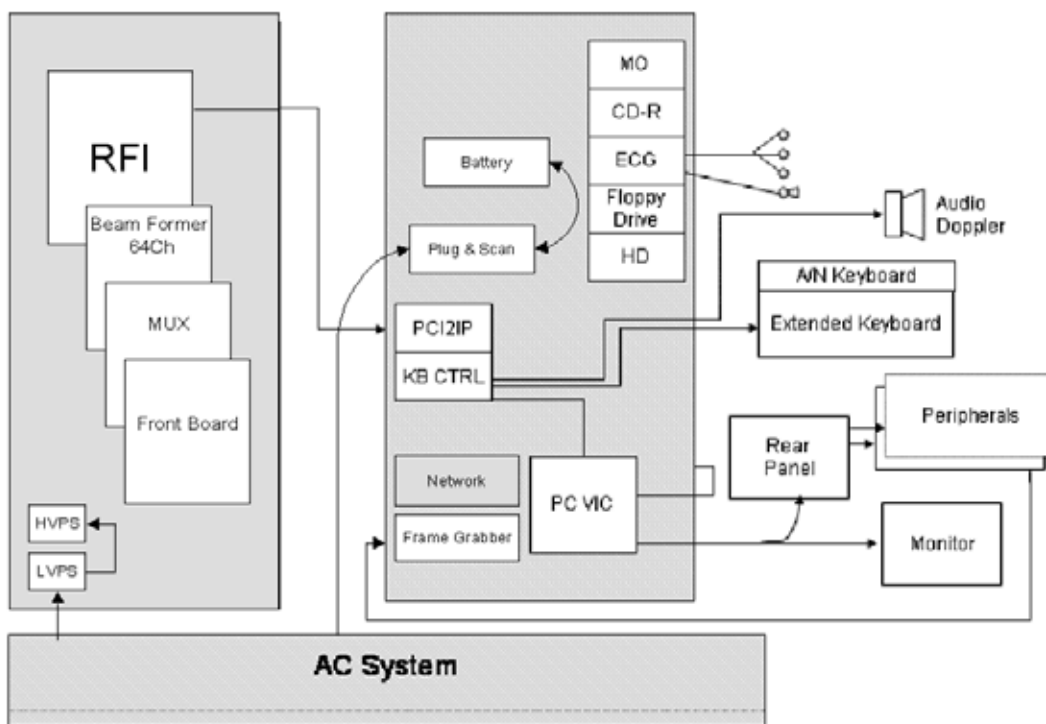

Figure 5-1 System Block Diagram - Vivid™ 3 BT03 - RFI Configuration

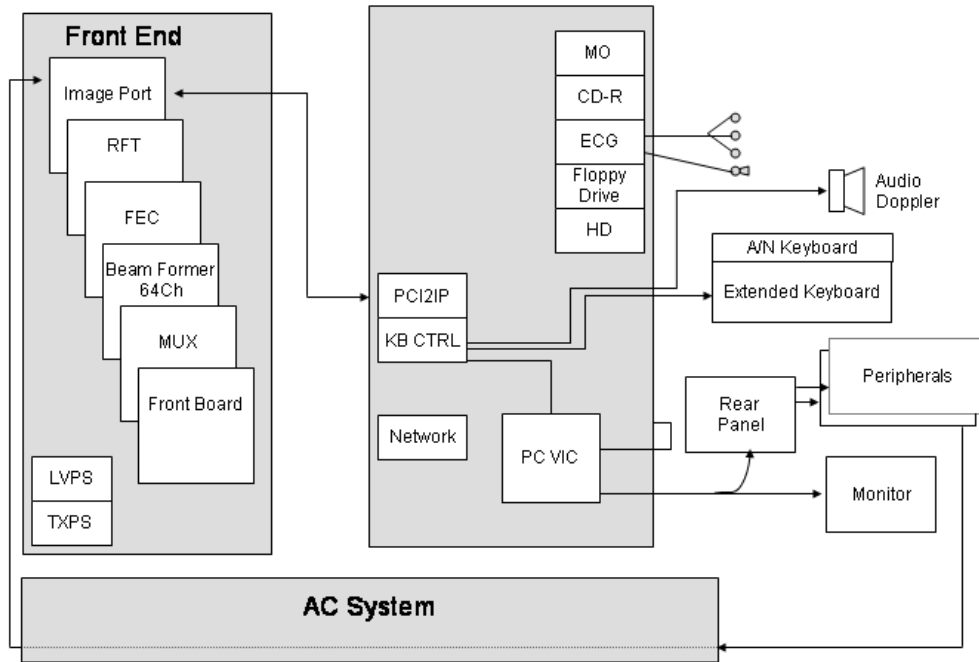

Figure 5-2 System Block Diagram - Vivid™ 3 BT03 - RFT Configuration

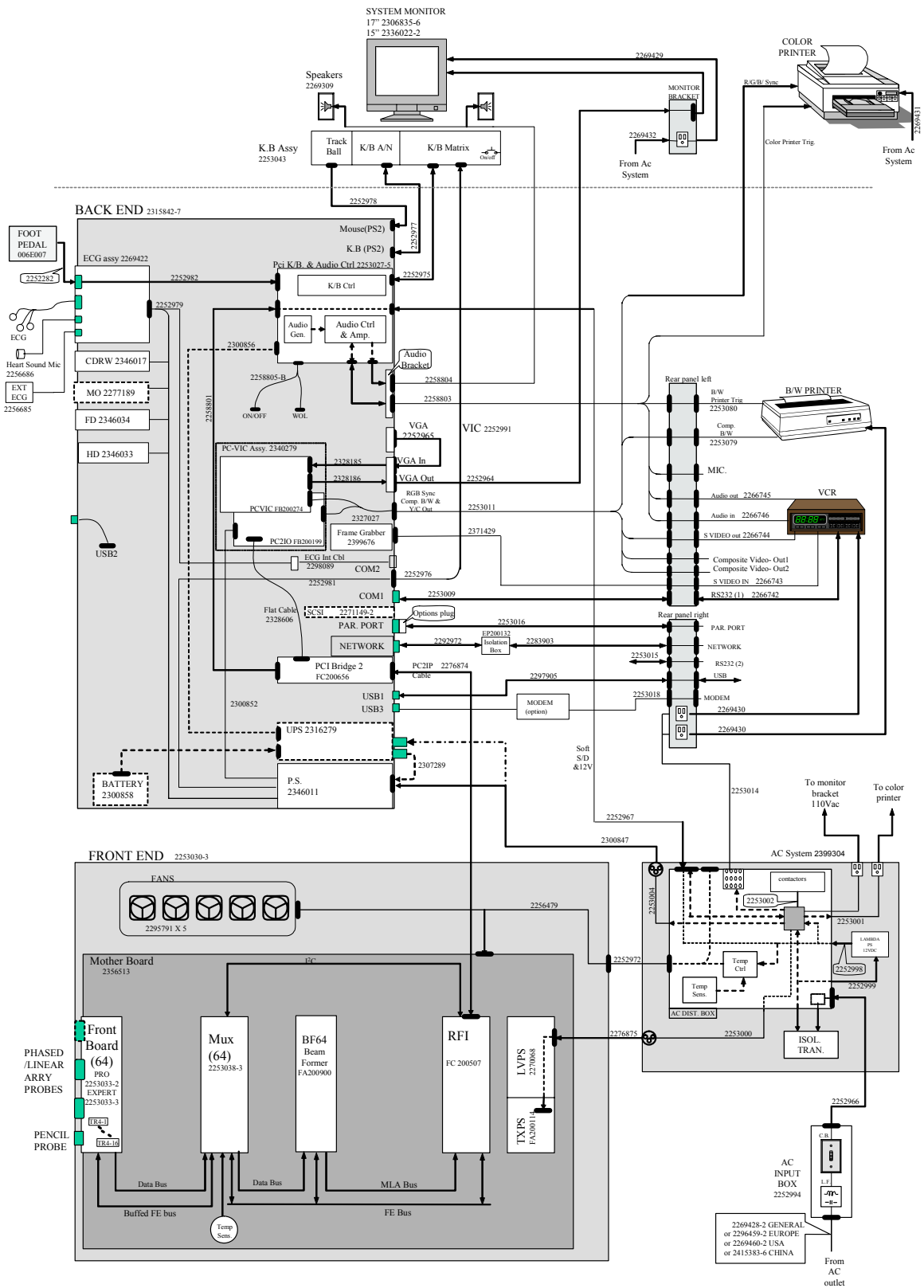

Figure 5-3 System Cabling Diagram - Vivid™ 3 BT03 - RFI Configuration

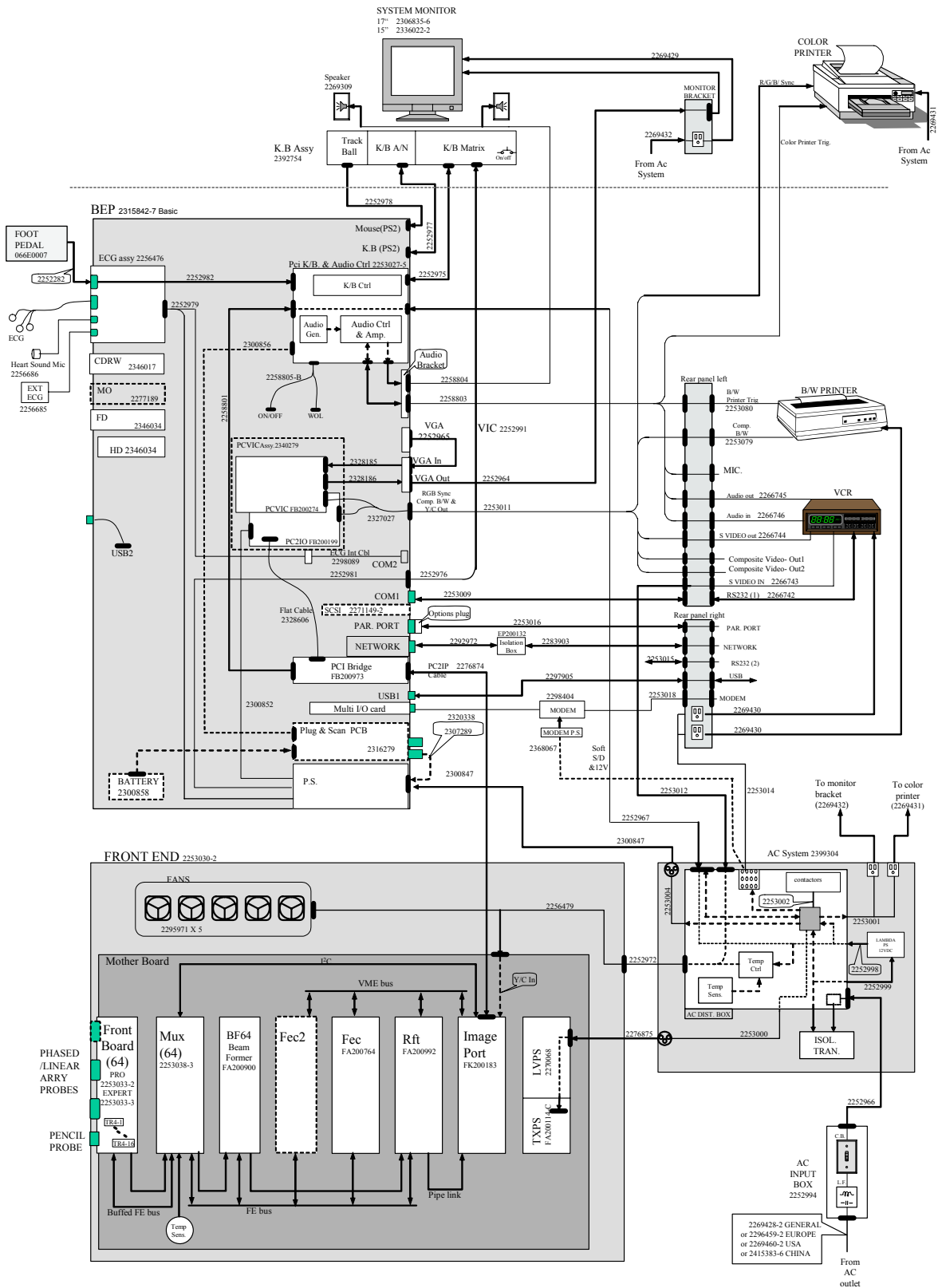

Figure 5-4 System Cabling Diagram - Vivid™ 3 BT03 - RFT Configuration

Section 5-4 Front End

5-4-1 General Information

The Front End includes all the boards in the Front End Card Cage, as follows:

- Front End Board
- MUX Board
- BF64 (Beamformer Board)
- RFI (Radio Frequency Interface Board)
 OR
 - * FEC (Front End Controller Board)
 - * RFT (Radio Frequency & Tissue Board)
 - * IMP2 (Image Port 2)

The Front End Crate includes five (or seven) components, as described in the following sections:

- [Front Board Assembly \(FB\)](#) on page 5 - 16.
- [MUX Board](#) on page 5 - 18.
- [Beamformer Board \(BF\)](#) on page 5 - 19
- [Radio Frequency Interface \(RFI\) Board](#) on page 5 - 20
 OR
 - * [Front End Controller Board \(FEC\) \(RFT\)](#) on page 5 - 23.
 - * [RF and Tissue Processor Board \(RFT\)](#) on page 5 - 24.
 - * [Image Port Board \(IMP\)](#) on page 5 - 25.
- [Back Plane Board \(Motherboard\)](#) on page 5 - 25.

Note: The VIC Board is located inside the VIC Assembly Unit and is not part of the Front End Crate, but rather a part of the Back End Processor. The VIC Board is described in detail in the [Back End Processor](#) section, page 5-26.

A block diagram of the Front End Crate is shown in the following figures:

Systems with **RFI** Configuration - see [Figure 5-1](#) on page 5-8.

Systems with **RFT** Configuration - see [Figure 5-2](#) on page 5-9.

For a detailed description of the Front End Crate components, refer to [Front End DC Power Distribution](#) on page 5 - 47.

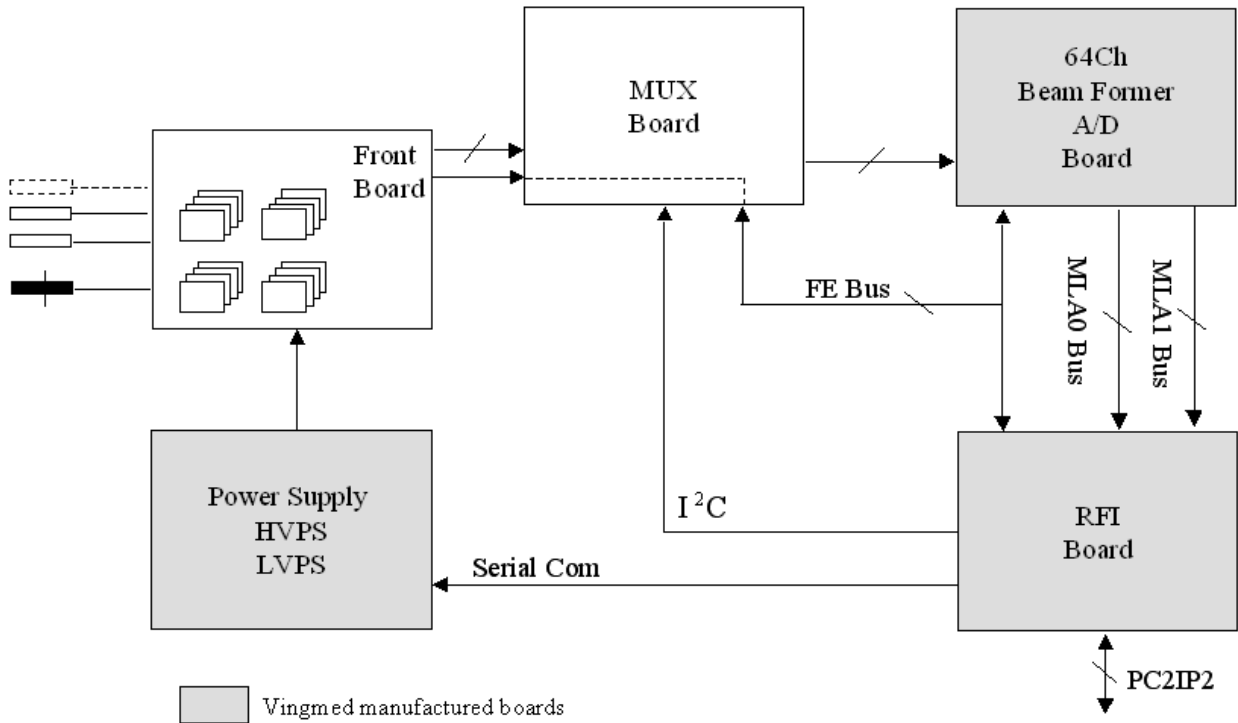

Figure 5-1: Front End Crate Block Diagram - RFI Configuration

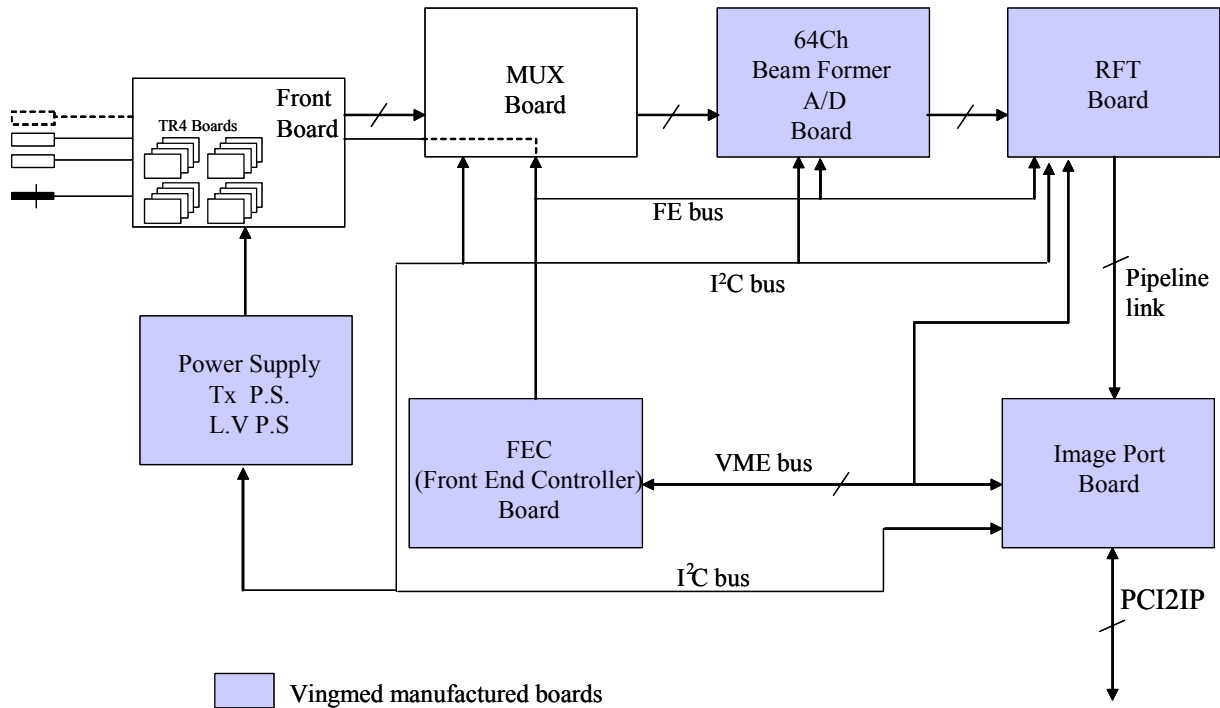

Figure 5-2: Front End Crate Block Diagram - RFT Configuration

The Front End can be divided into two subsystems, as follows:

1.) The **Front End subsystem** which includes:

- Front Board
- MUX Board
- BF64 (Beamformer Board)

2.) The **Mid Processors subsystem** which includes:

- RFI (Radio Frequency Interface Board)
- OR*
- * FEC (Front End Controller Board)
 - * RFT (Radio Frequency & Tissue Board)
 - * IMP (Image Port).

5-4-1-1 Front End Bus

Most of the FE boards are controlled by the Front End Controller or RFI board via a Front End Bus (FE_BUS). The FE_BUS is a synchronous and bidirectional bus built up by 16-bit data, 6-bit device address select, 10-bit page address and 8 strobe signals controlling the data transactions. The Front End Controller or RFI board can also read the revision status of the Front End boards through a serial line I²C to an E²PROM located on each board, and some probes.

5-4-1-2 Phased and Linear Array Front End

- The phased and linear array probes consist of several identical transducer elements (for example, 64, 128, 192). Three probes and a pencil probe can be connected to the system. The connectors are physically located on the FB board, where one of them is selected and connected to the transmitter (TX) and receiver (RX) through a number of relays.
- Depending on probe type and system setup, a certain scan pattern is selected on the FEC (or RFI) board. This board loads scan parameters for both the transmitter and the beamformer (steering- and focusing delays) into local RAM on these boards. Thus, when the FEC (or RFI) board goes through a scan sequence, it loads the proper contents of the RAM into the Transmitter Pulse Generator (TPG), then issues a transmit trigger pulse (TXTRIG_L) for the transmitter and a receive synchronization pulse (SYNC_L) for the beamformer. By firing the transmit pulses from the different elements at certain repeated time intervals and with different delays, the ultrasound beam can be steered in desired directions (re. principles of operation) obtaining the selected scan patterns (for example, 2D, 2D Flow, etc.).
- The ultrasound transmit bursts are generated on the Front board (FB), initiated by the transmit trigger pulse (TXTRIG_L). The transmit trigger starts the Transmit Pulse Generators (TPG) on the FB, each generating 16 transmit pulses with different delays. The transmit pulses are then routed to separate transmit "amplifiers" fed with voltage HV1 and HV2 which are controlled by the Acoustic Power control software.
- The transmit pulses are routed over TR4 boards located on the Front board (FB), where they are fed to the selected (one out of three) phased/linear array probe.
- The reflected signal from body structures and blood cells are routed from the probe, via the Front board over the TR4 boards, where pre amplification (20dB) and Analog Time Gain Compensation (ATGC) (-10 - +30 dB) is performed. Gain is determined by an analog signal (ATGC) generated by the FEC (or RFI) board.
At the input to the Front board are transmit/receive (T/R) switches to prevent the transmitters from destroying the receivers. Prior to pre amplification, the signals from the different channels were also fed through relays. This provides the possibility to route echoes from annular array probes into the receiver, in addition to injecting a test signal, TSIG.
- The output channels from the TR4 boards are fed to the MUX board via one Beamformer-64 board. The Beamformer board performs A/D conversion of 64 channels.
- The Front End Controller board controls all Front End boards (on systems with the RFT configuration). The board loads all parameters to the FB, MUX and Beamformer RAMs, it reads the probe identification, selects probe connector on TR4 boards and controls the high voltage multiplexer in linear probes. In addition, the board generates the following:
 - * a transmit trigger pulse for TR4.
 - * a receive synchronization pulse (SYNC_L) used by Beamformers and RF & Tissue Processor.
 - * a differential ATGC voltage used by TR4 and control signals for the High Voltage Power Supply (HVPS).
 - * system master clock generator (40 MHz).
 - * a reset pulse (SRES).

- The Radio Frequency Interface (RFI) board controls all Front End boards (on systems with the RFI configuration). The board loads all parameters to the FB, MUX and Beamformer RAMs, it reads the probe identification, selects probe connector on TR4 boards and controls the high voltage multiplexer in linear probes. In addition, the board generates the following:
 - * a transmit trigger pulse for TR4.
 - * a receive synchronization pulse (SYNC_L) used by Beamformers and RF & Tissue Processor.
 - * a differential ATGC voltage used by TR4 and control signals for the High Voltage Power Supply (HVPS).
 - * system master clock generator (40 MHz).
 - * a reset pulse (SRES).
 - * receive focusing control
 - * analog test signal generator
 - * temperature sensing for TEE probes
 - * step motor control for TEE probes
- The output from the Beamadders at BF is fed to the RFI (or RFT) board.

5-4-1-3 Transmitter Power Supply

The transmitters on the TR4 boards (HVPS on FB) are fed with high voltage from the TX supply. This module consists of three linear power supplies; one providing a symmetrical output voltage ranging from 0 to +/- 80 V (HV1), another providing a voltage ranging from 0 to +/- 40 V (HV2), and the third outputting +/- 80 V for the multiplexers in the linear probes. HV1 and HV2 are programmable through a serial interface from the FEC board.

5-4-1-4 Mid Processors

The Vivid™ 3 Front End and visualization system are interconnected through digital signal processing modules, called the Mid Processors. These processors perform the adequate signal conditioning for the different data types; *Tissue*, *Doppler* and *Flow*. The current Mid Processors are the RF & Tissue Processor board (RFT).

5-4-1-4-1 Pipelink Bus

- The Mid Processors are interconnected through a data bus system called the Pipelink. This is a uni-directional bus, transporting data from the pipelink dispatcher (RF & Tissue Processor) through the accessed processor, to the destination - the Image Port. The Image Port will then map the data into the Image Memory.
- Data leaving the RF & Tissue Processor have a tag indicating what type of data is transported; for example, *tissue*, *Doppler*, *2D Flow*. Each of the remaining mid processors decode this tag and when it matches their own address, the data is processed.
- In 2D mode, data is typically transferred in vector blocks from the RFT board. In Doppler and Color Flow, data from one range gate is transferred.

5-4-1-4-2 MLA-0 and MLA-1 Buses (RFI configuration only)

- The Mid Processors are interconnected through a data bus system called the MLA-0 and MLA-1. These are uni-directional buses, transporting data from the Beamformer to the Demodulator FPGA on the RFI.
- Data leaving the Demodulator FPGA have a tag indicating what type of data is transported; for example, *tissue*, *Doppler*, *2D Flow*. Each of the remaining mid-processor components decode this tag and when it matches their own address, the data is processed.
- In 2D mode, data is typically transferred in vector blocks from the Demodulator FPGA. In Doppler and Color Flow modes, data from one range gate is transferred.

5-4-1-5 Transmit Signal Path

The transmit signal is configured via the operating mode that was selected by the user. When this mode is selected, it sets those operating parameters for the FEC, and the FEC sends a signal to the high voltage power supply (HVPS) to program one of the supplies (HVPS1 or HVPS2).

Once the signal is transmitted, it is received by the transmit pulsor (TP) which is a switching device that will propagate the signal between different elements of the probe. The propagation of that signal depends on the way in which the FEC programs the Front board RAM table.

The signal from the HVPS comes in to the TP; the TP then generates a signal to the probe (connected to the Front board), in accordance with a command generated in Timing Pulse Generator (TPG). The TPG operates according to tables in the RAM table - see [Figure 5-6](#) on page 5-12.

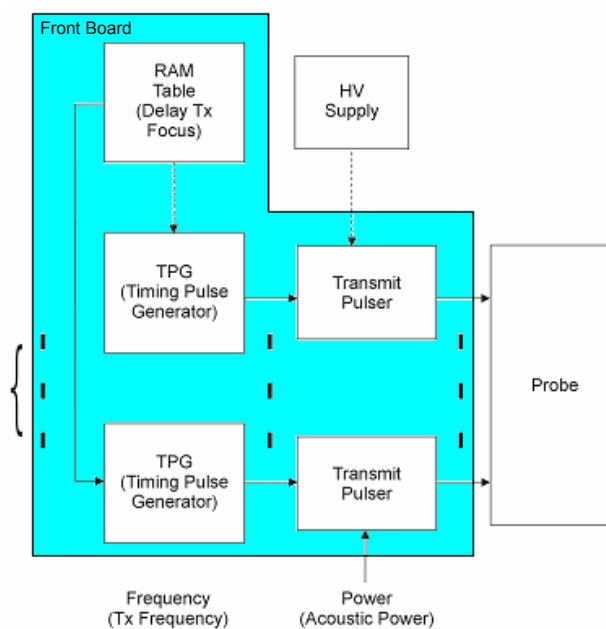

Figure 5-6 Transmit Signal Path Block Diagram

5-4-1-6 Received Signal Path

The receive signal is programmed according to the operating mode that was selected by the user. In some cases the signal is received immediately after it has been transmitted, sometimes after a prescribed delay, and in other cases at the same time as transmission (transmit/receive simultaneously).

Refer to [Figure 5-8](#) on page 5-15 or [Figure 5-8](#) on page 5-15, as appropriate.

The probe elements receive the echo signals from different depths. These signals are amplified and conditioned at the Analog Time Gain Compensation (ATGC) control. The different operating modes dictate in which way the signals are translated, as follows:

- *Continuous Mode (CW)* - echo signals are transmitted and received simultaneously, and translated per echo point for a specified depth. This provides a real-time image.
- *2D Mode* - signals are received from all 64 channels (if a probe has more than 64 elements, the MUX of the probe is used to create the additional missing channels). The signals are transmitted at a prescribed delay between the elements, and immediately after this are received (all the time, aiming at one point at a specific depth). In this way, echo signals are collected from all points along a certain line, from which a vector is created. The vector is transmitted to the MUX board, and from there to the Beamformer where it is amplified and undergoes analog-to-digital conversion. From here RF signals are transmitted to the RFT board, where an image is created.
- *Color Flow Mode (CFM)* - shows the movement of particles (this mode is usually used together with 2D mode). In CFM mode, the echo signal received is used to measure the amount of frequency phase change (degree of shift) - this is referred to as the *Doppler effect*. When using CFM and 2D modes together, at the same time that the signal is received, in parallel it is used to generate a signal through a circuit that translates the Doppler effect, and from which it generates a color image.

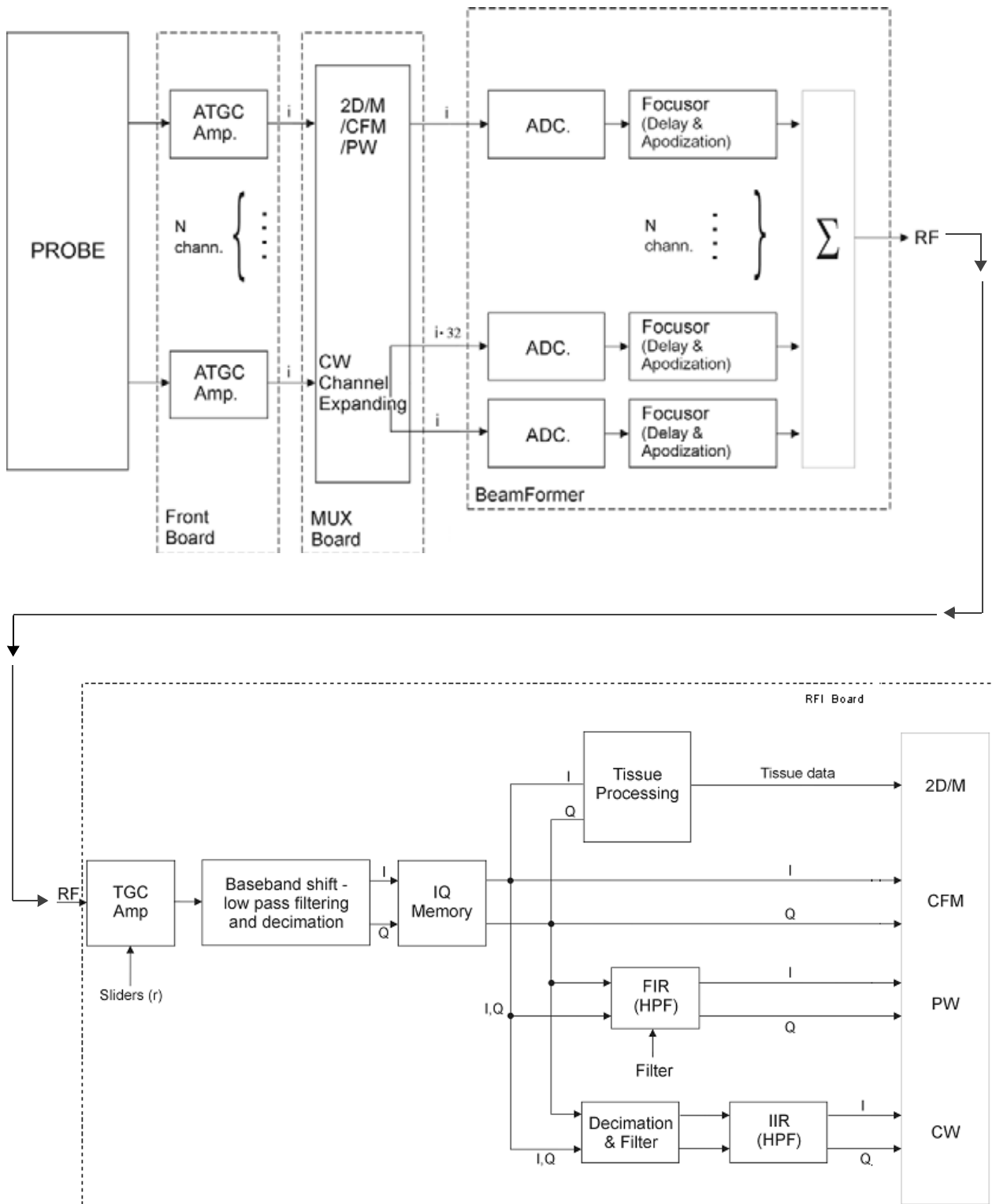

Figure 5-7 Received Signal Path Block Diagram - Systems with RFI Configuration

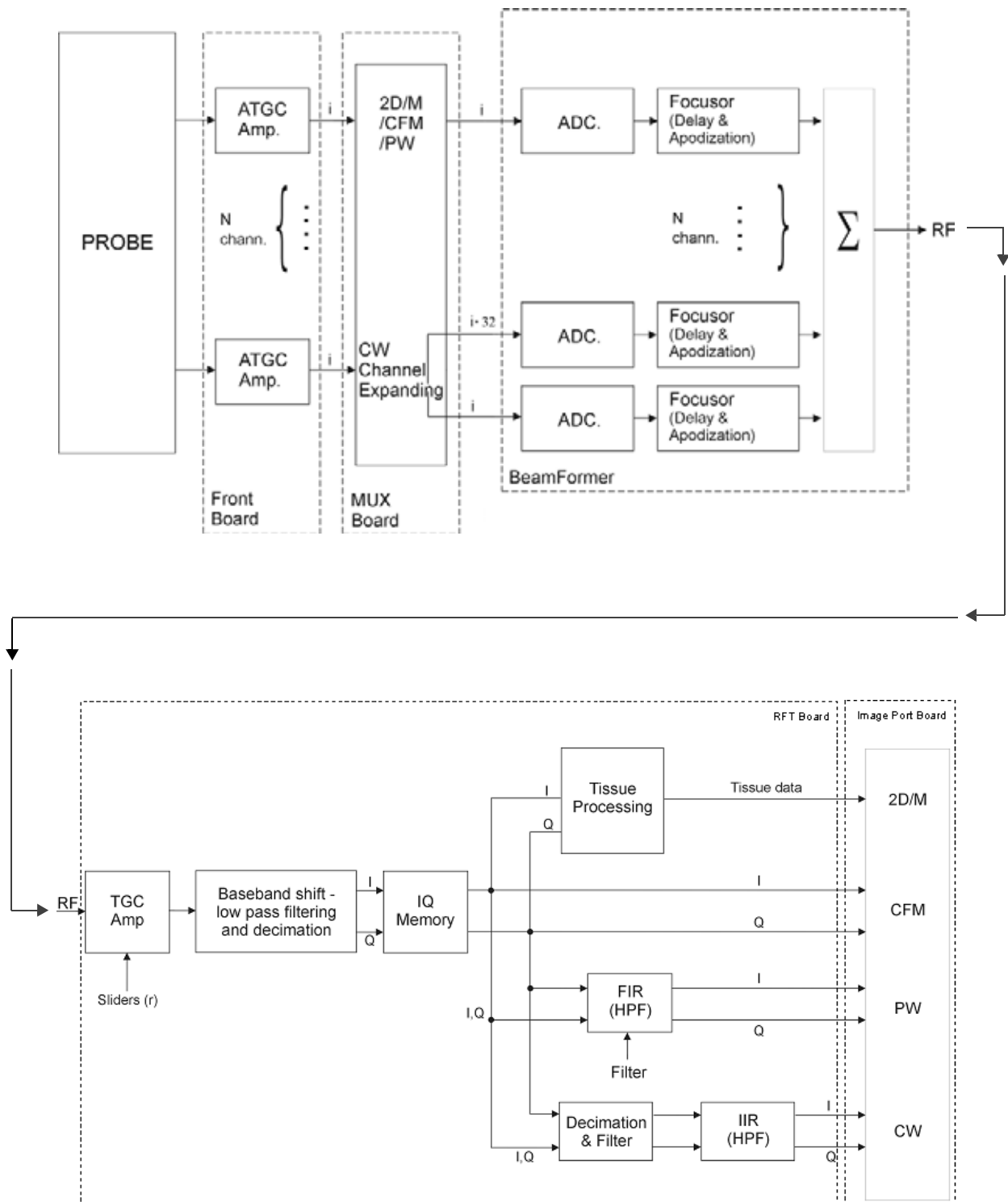

Figure 5-8 Received Signal Path Block Diagram - Systems with RFT Configuration

5-4-2 Front Board Assembly (FB)

5-4-2-1 General Description

The FB Board has 64 identical receive channels.

The signal in each channel is fed via a Transmit/Receive (T/R) switch to a preamplifier. The next step is a Time Controlled Gain (TGC) amplifier used to equalize the signal strength from the near-field, the mid-field and the far-field.

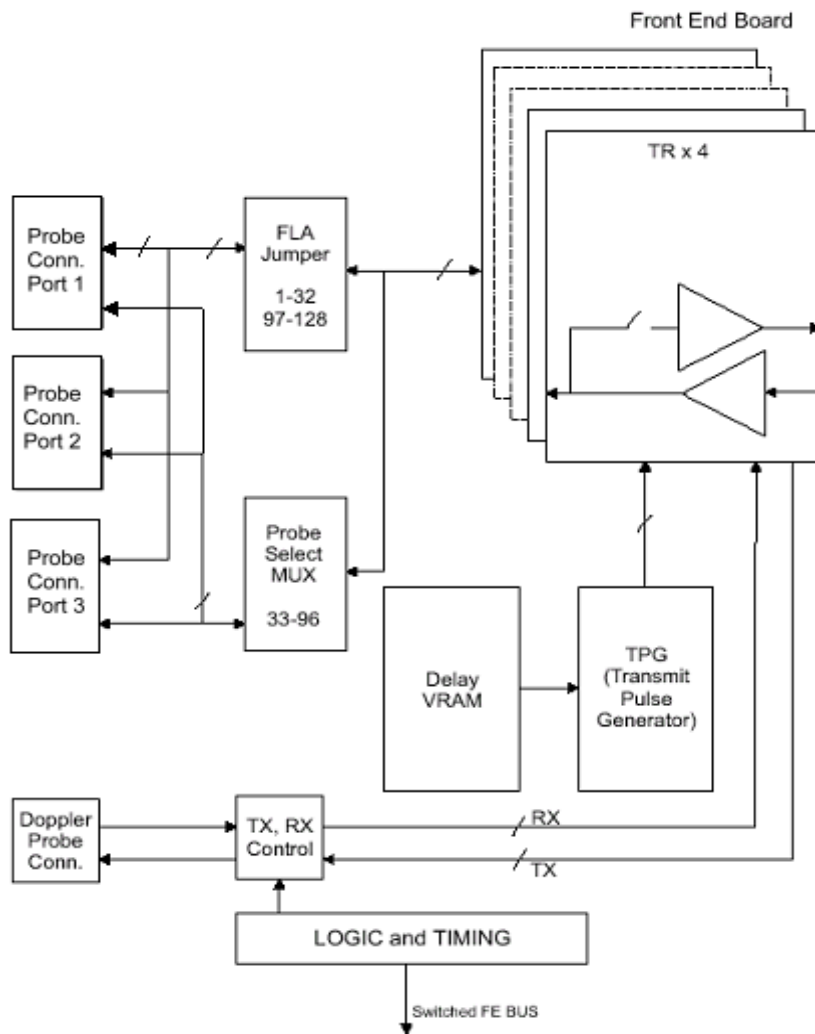

Figure 5-9 Front Board Assembly Block Diagram

5-4-2-2 TR4 Board Description

The TR4 Board has four transmit and receive signal channels. Each channel has two pulsars for different transmitted Tx voltages, and a low-signal receiver amplifier. Both are connected to the same input/output line. The receiver is buffered from the transmitted voltage (up to 80V) by an electronic switch to avoid high voltage on the receiver input.

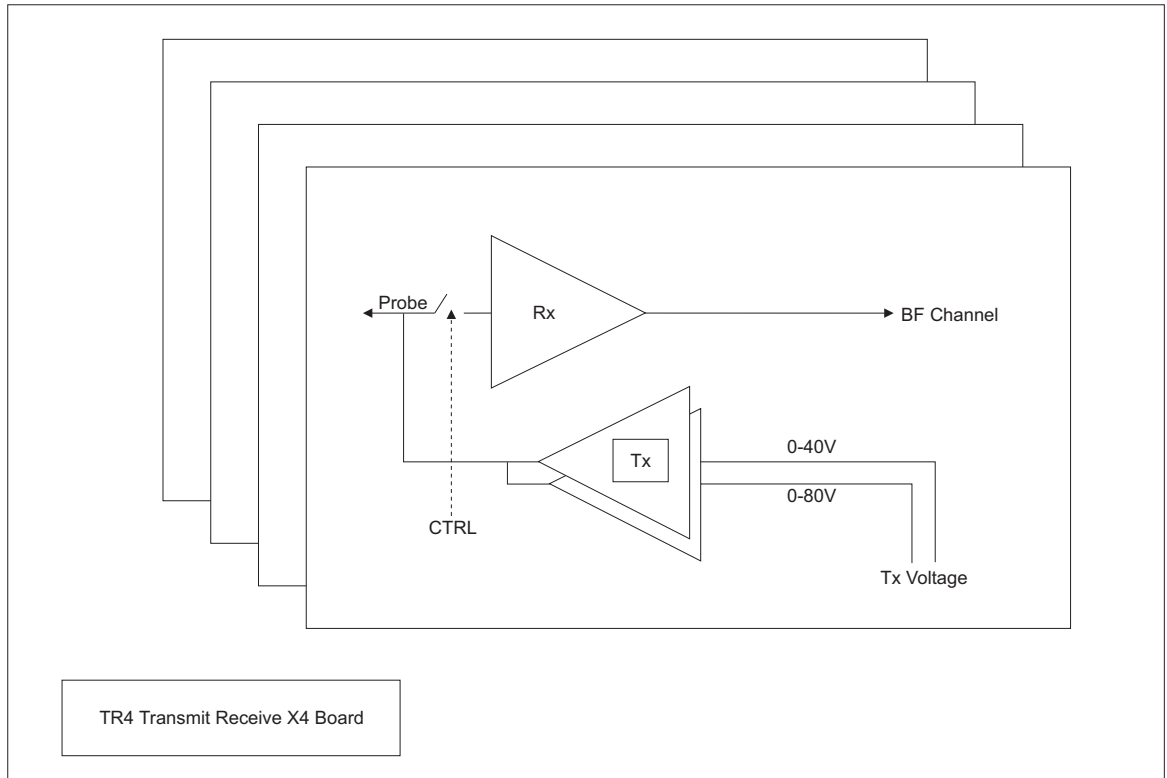

Figure 5-10 TR4 Board Block Diagram

5-4-3 MUX Board

5-4-3-1 General Description

The MUX Board has 64 identical receive channels, and performs the following functions:

- Receiving the channels and connecting them to the BF Boards.
- Expanding the low/high channels in CW mode.
- TEE motion control.
- Monitoring temperature and voltage measurements via the I²C.
- FE Bus switch. To reduce the noise in the FE cards, the MUX switches off the FE Bus to the FB during the data acquisition in CW mode.
- Min/max AC input monitoring, every ten seconds.

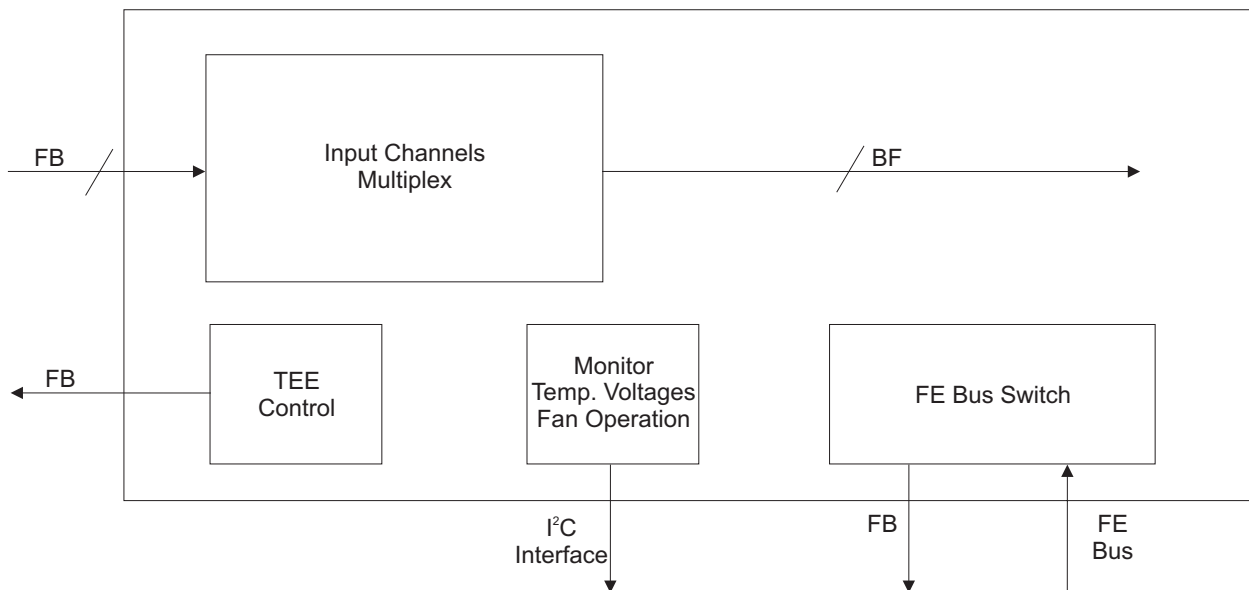

Figure 5-12 MUX Board Diagram

5-4-4 Beamformer Board (BF)

5-4-4-1 General Description

The Beamformer Board (BF Board) contains the A/D converter, the ASIC (called the Focuser [FOC]) and a Beam Adder (BA). The BF Board accepts input channels and converts each channel to digital bytes.

The system requires one BF Board which scans 64 channels.

The digitized samples at the ADC output are input to the FOCs, whose outputs go to a BA. The output of the BA (BA Level 2) is the sum of the input channels, which is added together with the output from the other BA Level 2, as shown in Figure 5-14 on page 5-19.

These ASICs will add all the input and output channels, with appropriate delay, to give optimal receive focusing and beam steering as a function of time. All focusing and steering parameters for a scan are stored in VRAM on the BF Board. The output of the BF Board is a high-frequency digital Word update. This output can be added to any successive board, if more channels are required.

- **BF Calibration:** The system has a calibration procedure for the BF Board, which sets the offset voltage for the ADC on the BF Board. If the BF Board is replaced, the calibration procedure has to be performed, as described in [Beamformer Calibration](#) on page 6 - 17.
- **BF Board Location:** The BF Board can be placed in the Front End Crate, in the third slot from the left side.

5-4-4-2 Description of Operation

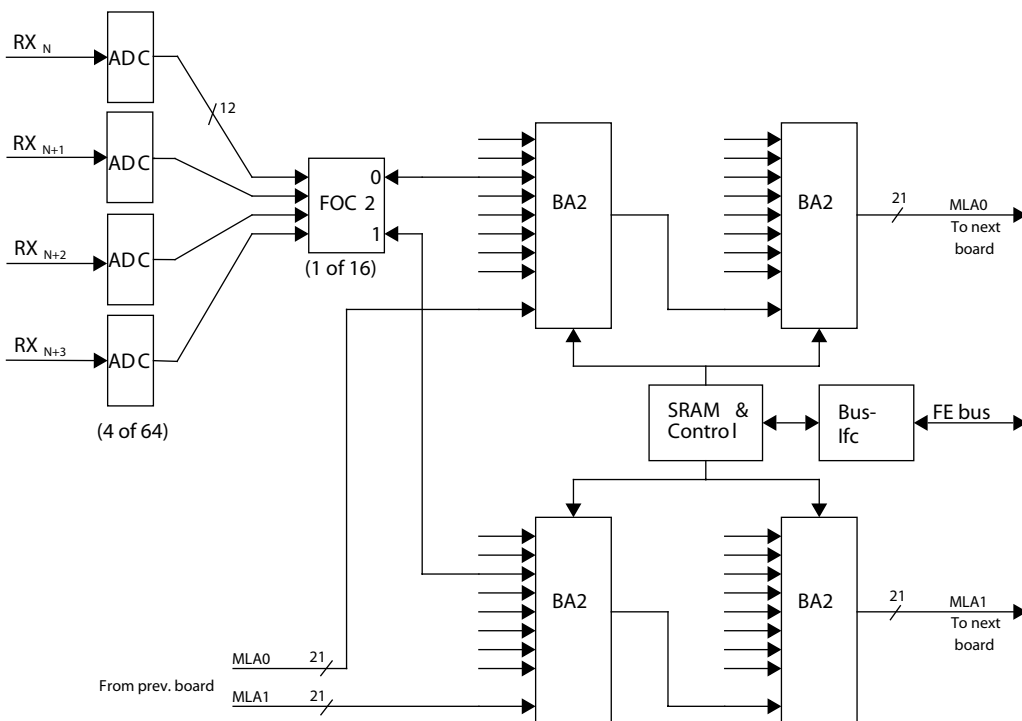

Figure 5-14 Beamformer Board (32 Channel) Block Diagram

5-4-5 Radio Frequency Interface (RFI) Board

5-4-5-1 General Description

The Radio Frequency Interface (RFI) board has been introduced in the manufacture of Vivid™ 4 systems, as a result of certain hardware components having become obsolete.

The functionality of the following boards is implemented on the RFI board:

- Front-End Controller (FEC) board
- RF & Tissue (RFT) board
- Image Port (IMP) board

NOTE: *On Vivid™ 4 systems with the RFT configuration, the FEC, RFT and IMP board functionality is still implemented on the BEP via separate boards. These are described in this chapter in the following sections: [Front End Controller Board \(FEC\) \(RFT\)](#) on page 5-23; [RF and Tissue Processor Board \(RFT\)](#) on page 5-24; [Image Port Board \(IMP\)](#) on page 5-25.*

Tasks Performed by the RFI board:

- System Master Clock generator
- Transmitter Control
- ATGC Control
- Receive Focusing Control
- Analog Test Signal Generator
- High Voltage Control and supervision
- Probe Sensing
- Control of MUX board, Front Board, and Beam Former
- Temperature Sensing for TEE probes
- Step Motor Control for TEE probes

5-4-5-2 Signal Flow

The digitized signals from the Beam Formers are connected to the RFI module. The Digital Signal Processor on the RFI board, together with software on the BEP, performs the adequate signal conditioning for the different data types; *Tissue, Doppler* and *Color Flow*.

In addition, Doppler Audio Processing is performed by the RFI board. (The Doppler Spectrum Processing is done by the BEP).

The RFI extracts Tissue Data, Spectrum Data and IQ & Color Data from the digital data stream on its input, and it also performs RF filtering and different types of Tissue Processing.

5-4-5-3 RF Processing

Different types of RF processing is performed, depending on later usage of the data:

- RF Demodulation
- Digital Time Gain Compensation
- Filtering
- Decimation

5-4-5-4 Data Buffer

After RF filtering, the data is written into different sliding ring buffers, dedicated to the different types of data. While data is written into the buffers sample-by-sample in vectors, multiple samples from the same range (depth) can be read out.

Both input addressing (start and length) and output addressing (through output events) are controlled by the RFI board itself.

5-4-5-5 Tissue Processing

A number of different tissue processes are performed on the RFI board:

- 1.) Firstly, the signal amplitude is obtained by *detection*.
- 2.) Then the data is compressed to attenuate the strong signals and amplify the low level echoes.
- 3.) After compression, *Zone Stitching* is performed. Zone Stitching is used to combine the (transmit) focal zones from different vectors into one vector by weighting the zone transitions, and only applies to phased/linear array probes where multiple vectors can be collected in the same direction. For M-Mode, *peak detection* and *edge enhancement* is implemented.
- 4.) Finally, in some cases, an offset can be added to the signal and clipping is performed.

5-4-5-6 Color Flow Processing

No Color Flow processing is performed here, except for the RF demodulation previously mentioned. The data used for Color Flow is tagged with the appropriate headers and tails and sent to the Back-End Processor (BEP).

5-4-5-7 Doppler Data

On the RFI board, Doppler Data is high pass filtered (to remove strong low frequencies returned from wall motion, valves and leaflets) and then sent to the BEP, and to Audio Circuitry on the KB Control Board.

5-4-5-8 System Temperature Surveillance

The RFI board monitors the temperature in the airflow at the air intake, and in the airflow at the air outlet.

These measurements make it possible to monitor the environmental conditions (temperatures) for the scanner and prevents overheating.

5-4-5-9 Probe Management

The RFI board performs the following probe management functions:

- Controls the selection of a probe connector
- Senses the Probe *type*
- Senses the Scan Plane Angle on MPTE and PAMPTE probes
- Senses the Probe *temperature*
- Turns OFF the probe if the temperature exceeds the *maximum* temperature.
The temperature references are set to 41.3 °C and 43.0 °C.
- Turns OFF the probe if the temperature reading falls below *minimum* temperature
The minimum temperature references is set to 15 °C. A temperature reading as low as 15 °C indicates a probe temperature-sensing error.

5-4-5-10 TX Power Supply Management

The TX Power supply has two separate voltage outputs, as follows:

- **TX Power Supply #1 (TX1)** - generates voltage levels for pulsed TX operations
- **TX Power Supply #2 (TX2)** - generates voltage levels for both pulsed and CW operations

The RFI sets the voltage level for the two TX Power Supply outputs (*TX1* and *TX2*) and also measures the voltage levels and current drain from the two TX outputs. If any of the values *exceed* the limit for a given mode, the RFI will turn OFF power to the probe.

5-4-6 Front End Controller Board (FEC) (RFT)

The Front End Controller (FEC) Board controls other boards in the Front End Crate. The control is done through a synchronous and bidirectional Bus called the Front End Bus. The following tasks are performed by the FEC Board:

- System master clock generation (including clock to IP).
- Transmitter control.
- ATCG control.
- Receive focusing control.
- Analog test signal control.
- Probe sensing.
- Transmit voltage control.
- Control of Front Board switching.
- Temperature sensing for the TEE probes.
- Memory refresh control for the BF Board.
- Provide 40 MHz clock to IP.

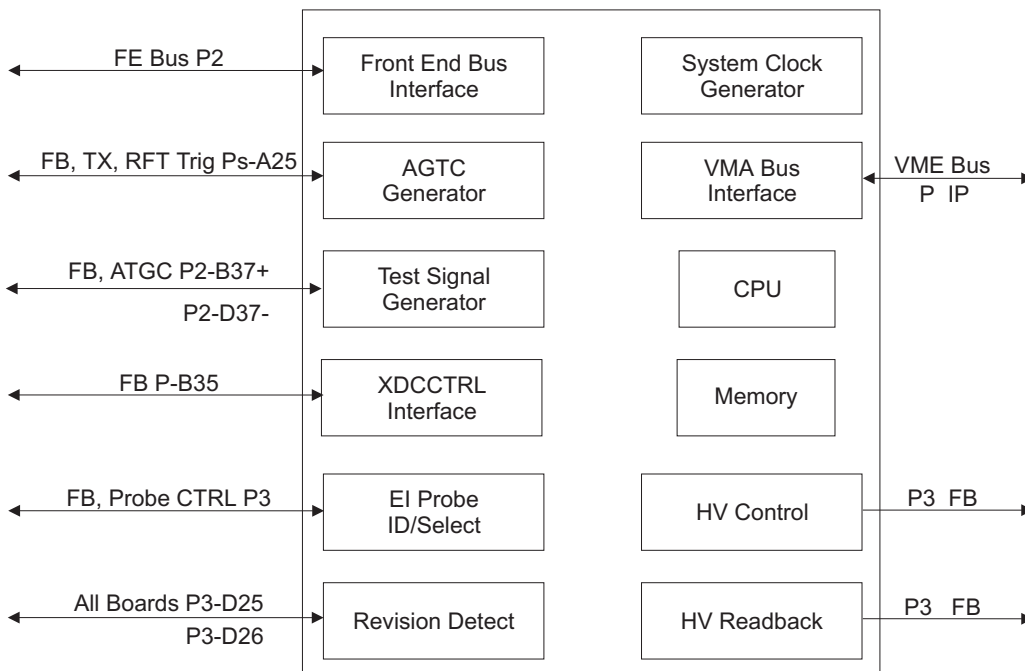

Figure 5-1: Front End Controller Block Diagram

5-4-7 RF and Tissue Processor Board (RFT)

The RF and Tissue Processor Board (RFT) receives data from the BF1 Board in the Front End. Both types of data samples (RF_MODE) are communicated to the RFT Board from the Front End Controller Board, via the Front End Bus.

5-4-7-1 Control

The RFT Board has a local DSP with an external EPROM. The DSP performs the following control tasks:

- Handles communication with the BE over the VME Bus and the PCI Bus.
- Updates filter coefficients and other parameters in the data path.
- When output events are received from the FEC, the RFT Board sets up the pipe link to output control, for data tagging and transfer.
- During transfer of time motion data, the RFT Board creates a “time slot” data transfer, which replaces the output event base transfer.

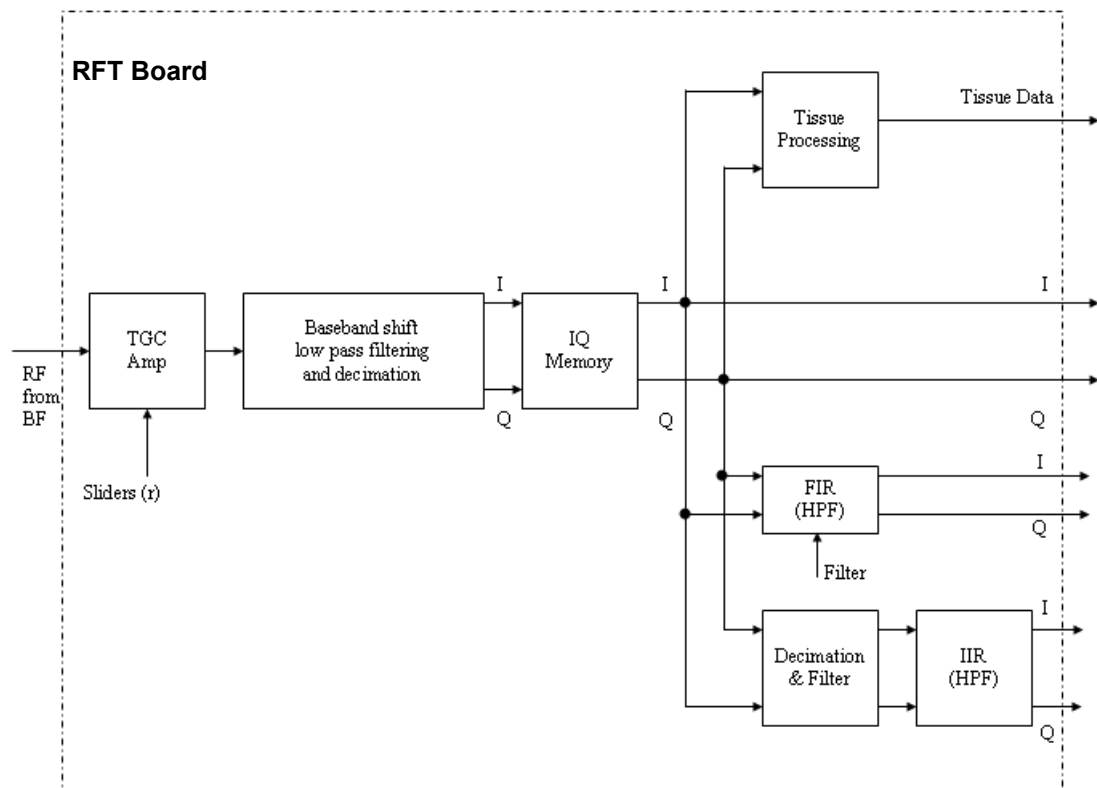

Figure 5-17 RFT Processor Board

5-4-8 Image Port Board (IMP)

The function of the Image Port (IMP) is to receive signals from either the RFT (during scanning) or the VCR (during playback), capture them, and route them to the Back End Processor (BEP) via the PC2IP Bus. The IMP handles all the communication from the BEP to the Front End Cards and back through the VME Bus - see [Figure 5-18](#) below.

The IMP is used as a connection to the BEP. All the instructions to the Front End Crate are sent via the IMP, and all the outgoing data is transferred to the BEP via the IMP through the PCI Bus.

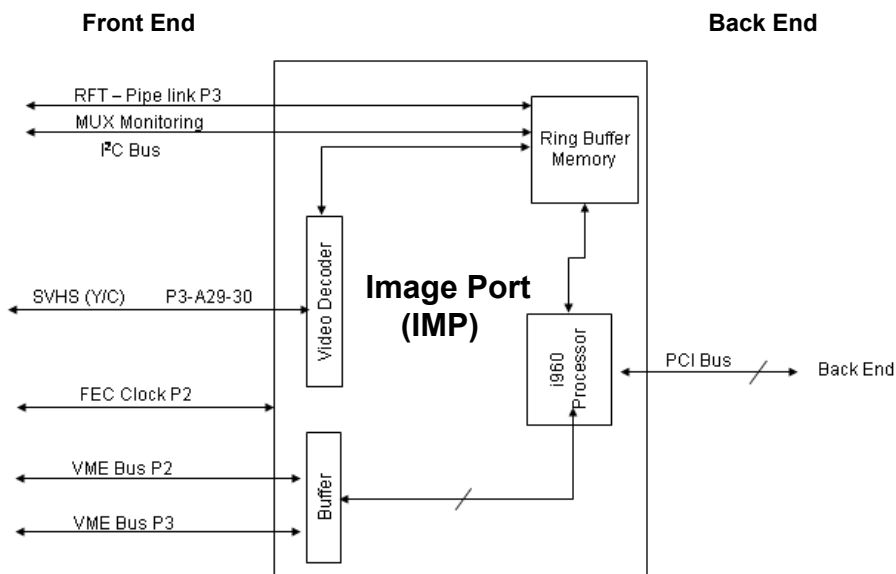

Figure 5-18 Image Port Block Diagram

5-4-9 Back Plane Board (Motherboard)

The Back Plane Board serves as a mother board which connects all the boards' signals. It also distributes the low voltages for the FE Crate boards and the TX voltages. It hosts all the FE boards, as shown in the following figures:

- Systems with **RFI Configuration** - see [Figure 5-1](#) on page 5-8.
- Systems with **RFT Configuration** - see [Figure 5-2](#) on page 5-9.

Section 5-5 Back End Processor

5-5-1 Introduction

The Back End Processor (BEP) supports the operation of the Vivid™ 3 ultrasound unit and is the main controller for the unit. The BEP comprises the various components described in the following sections:

- [Central Processing Unit \(CPU\)](#) on page 5 - 31.
- [Keyboard Controller](#) on page 5 - 34.
- [Frame Grabber \(RFI systems only\)](#) on page 5 - 35.
- [PC2IP](#) on page 5 - 35.
- [Plug and Scan Card and Battery](#) on page 5 - 35.
- [Network Onboard](#) on page 5 - 35.-
- [SCSI Card](#) on page 5 - 35.
- [Floppy Drive](#) on page 5 - 36.
- [Hard Disk](#) on page 5 - 36.
- [Magneto-Optical Drive \(MOD\)](#) on page 5 - 37.
- [CD Read Write \(CDRW\)](#) on page 5 - 37.
- [ECG Module](#) on page 5 - 37
- [Modem](#) on page 5 - 38.
- [PC-VIC Assembly](#) on page 5 - 39.

[Figure 5-19](#) on page 5-27 shows the location of the various components within the BEP for BT02/BT03 systems with the RFI configuration. For systems with the RFT configuration, see [Figure 5-20](#) on page 5-28.

A block diagram of the BEP in Vivid™ 3 systems with the RFI configuration is provided in [Figure 5-21](#) on page 5-29. For systems with the RFT configuration, see [Figure 5-22](#) on page 5-30.

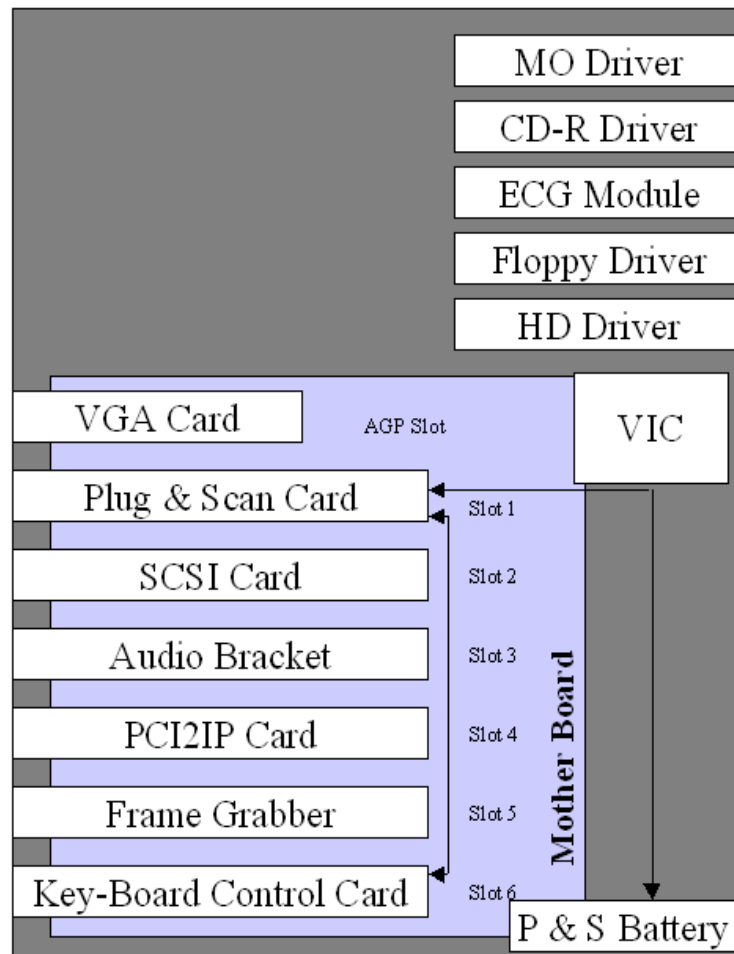

Figure 5-19 Back End Component Locations - BT02/BT03 (RFI Configuration)

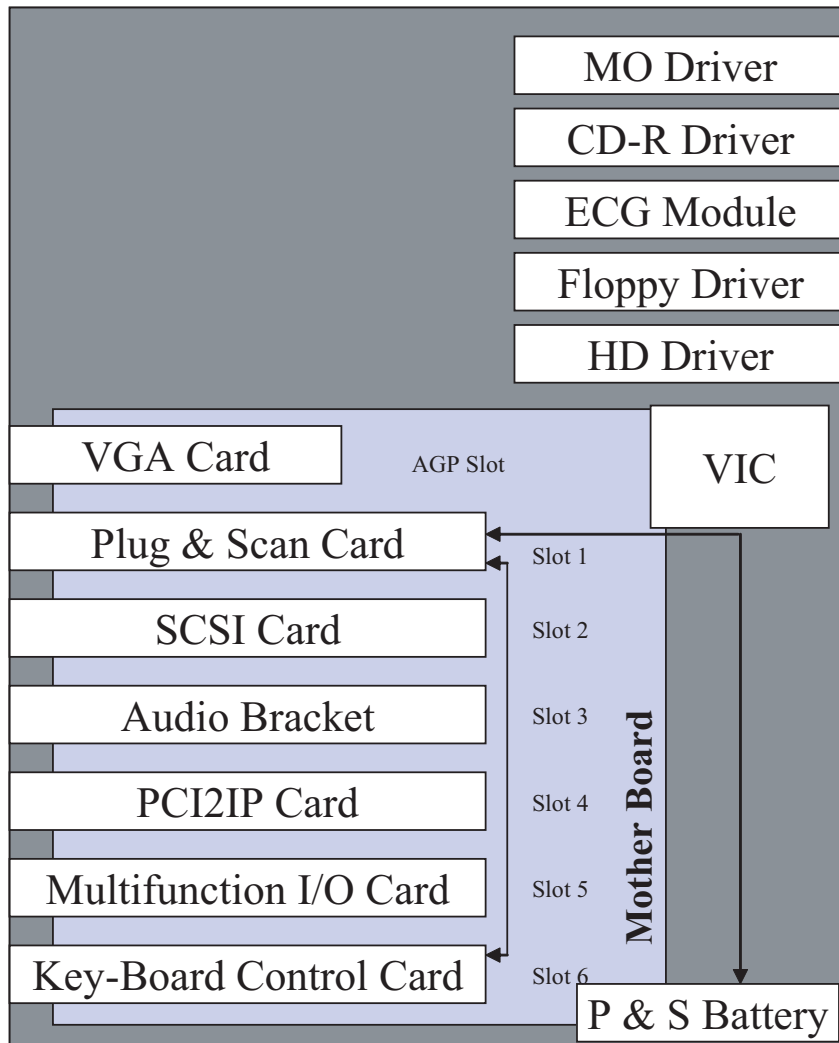

Figure 5-20 Back End Component Locations - BT02/BT03 (RFT Configuration)

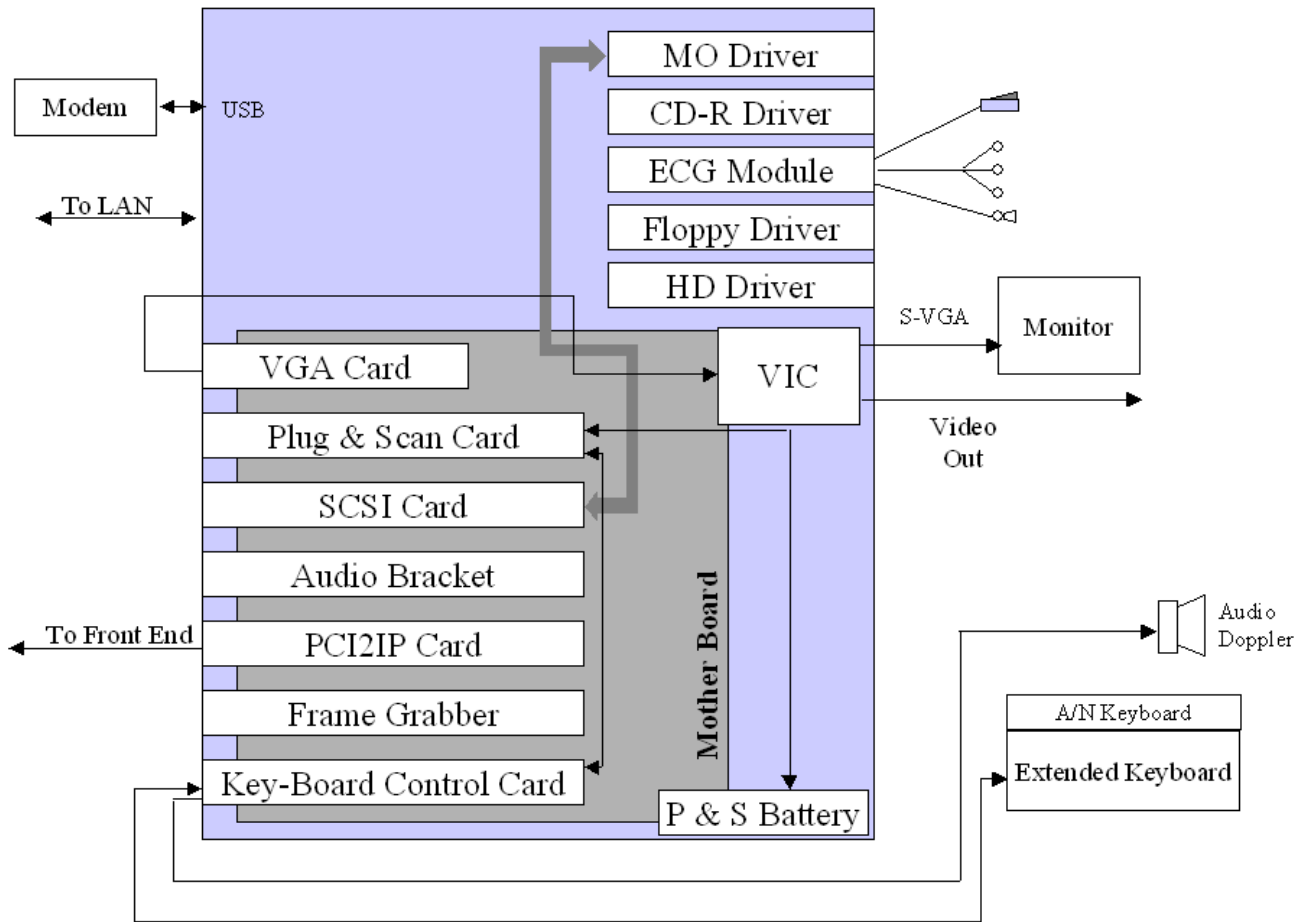

Figure 5-21 Back End Block Diagram - BT02/BT03 (RFI Configuration)

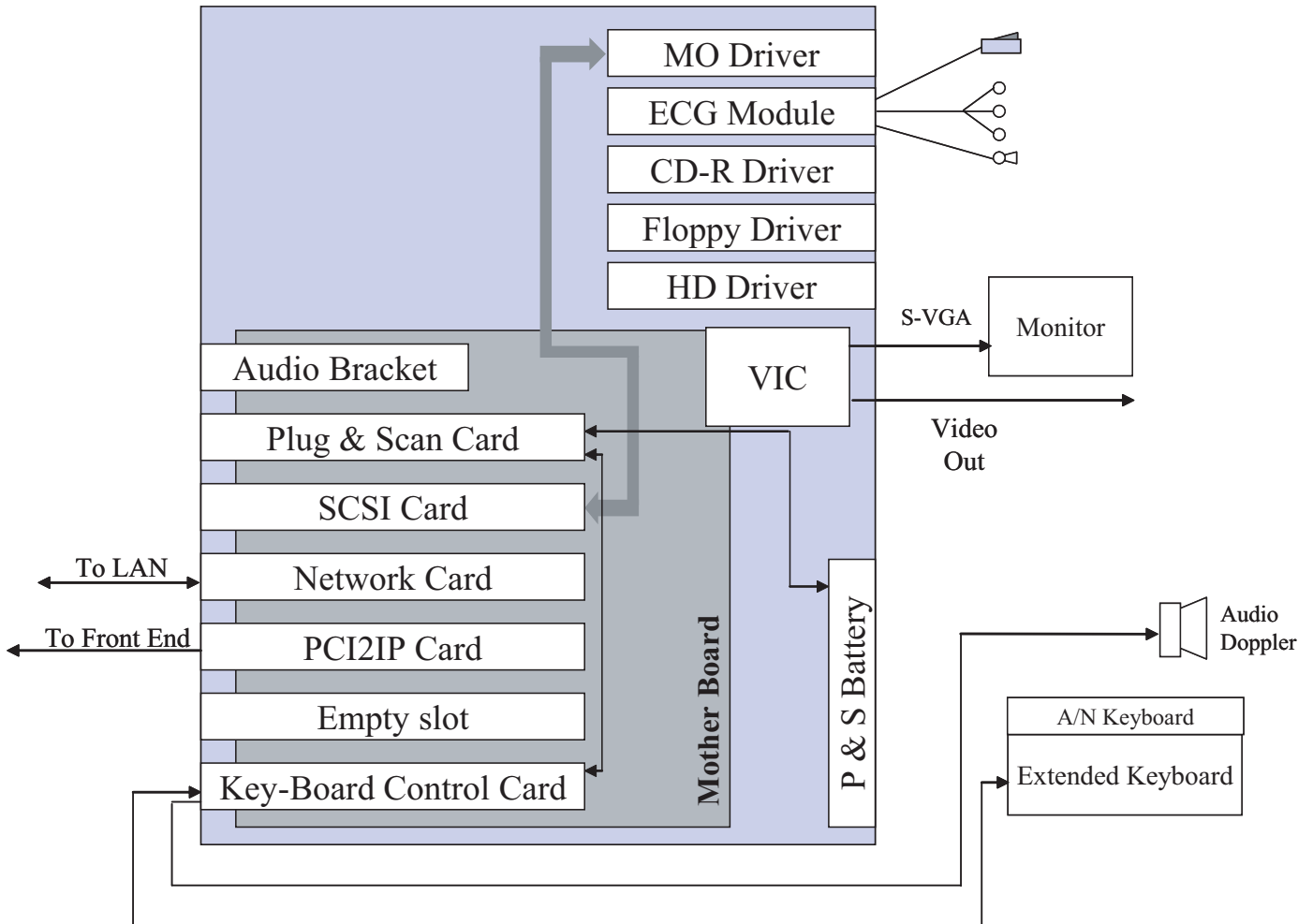
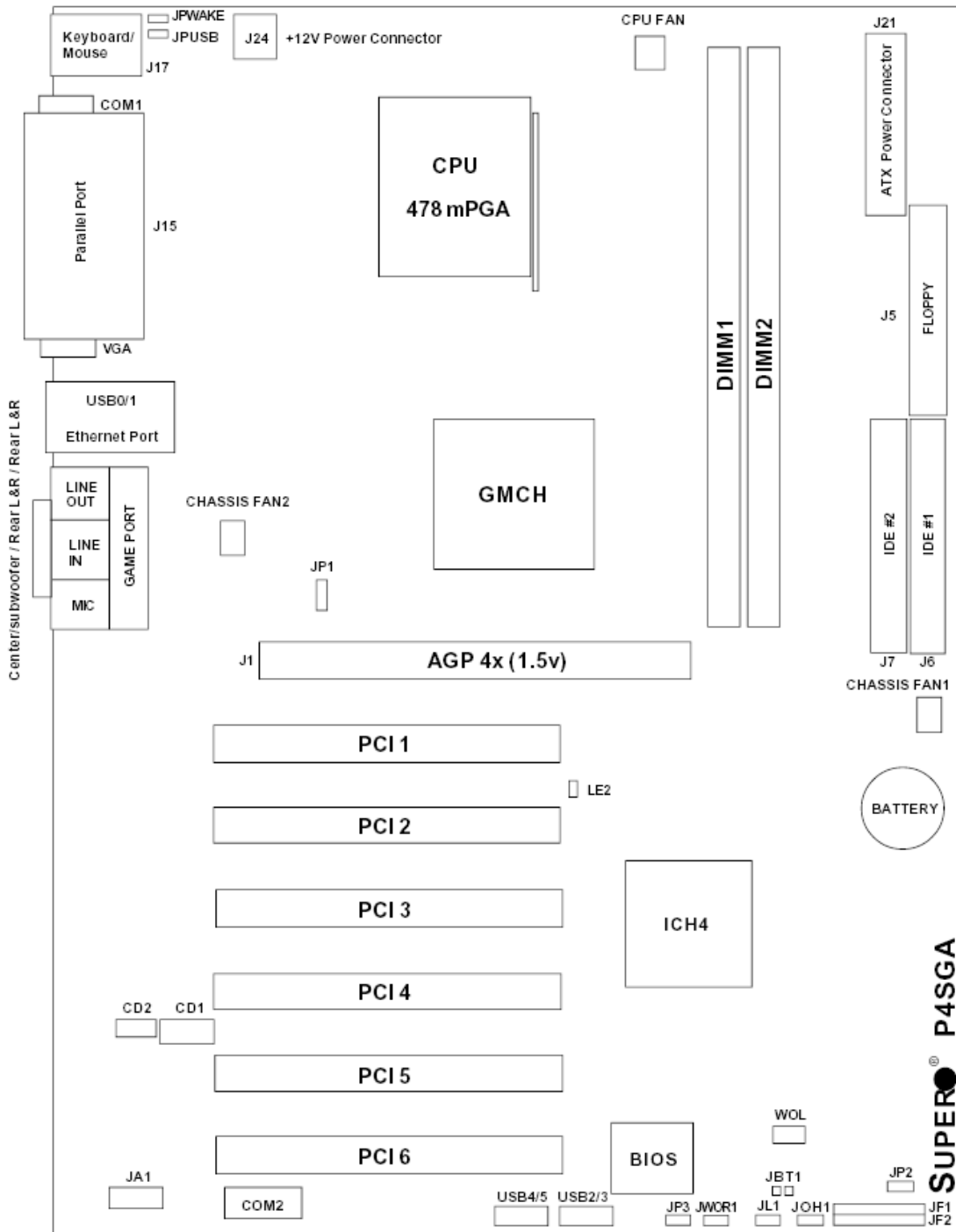

Figure 5-22 Back End Block Diagram - BT02/BT03 (RFT Configuration)

5-5-2 Central Processing Unit (CPU)

The CPU controls and processes the internal Back End Processor operations. In addition, the CPU supports the Front End Crate via the IP card. The CPU used in the Vivid™ 3 ultrasound unit is a Pentium 4, 2 GHz Intel Processor, or newer. On older units (Pentium III) the CPU is 1 GHz.



Note: Not drawn to scale

Figure 5-23 BEP Motherboard Layout - BT02/BT03

Table 5-6 BEP Motherboard Layout BT02/BT03 - Legend to [Figure 5-23](#)

Jumpers	Description	Default Setting
BT1	CMOS Clear	Open (Disabled)
JP1	Front Side Bus Speed	Pins 1-2 (Auto)
JP2	Watch Dog Enable	Open (Disabled)
JP3	Speech Output Select	Pins 1-2 (Speaker)
JPUSB	USB0/1 Wake Up	Pins 1-2 (Disabled)
JPWAKE	Keyboard Wake-Up	Pins 1-2 (Disabled)
Connectors	Description	
CD1	Audio CD Input (large connector)	
CD2	Audio CD Input (small connector)	
Chassis Fan1/2	Chassis Fan Header	
COM1/COM2	COM1/COM2 Serial Port Connector/Header	
CPU Fan	CPU Fan Header	
DIMM1/2	Memory (DIMM) Slots	
Ethernet	LAN (Ethernet Port)	
Game Port	Game Port	
J1 ^a	4xAGP	
J5	Floppy Disk Drive Connector	
J6/J7	IDE #1/#2 Hard Disk Drive Connectors	
J15	Parallel Printer Port	
J17	PS/2 Keyboard/Mouse	
J21	ATX 12V Power Connector (20-pin)	
J24 ^b	ATX 12V Power Connector (4pin)	
JA1	SPDIF Connector	
JF1, JF2	Front Control Panel	
JL1	Chassis Intrusion Header	
JOH 1	Overheat LED	
JWOR1	Wake-On-Ring Header	
LE2	5v Standby Warning LED	
LINE IN	Audio In Connector	
LINE OUT	Audio Out (Speaker) Connector	
MIC	Microphone Input	
USB2/USB3	Universal Serial Bus Port 2/3	
USB4/USB5	Universal Serial Bus Port 4/5	
WOL	Wake-On-LAN	

a. P4SGA only

b. The 4-pin connector at J24 must be connected to meet the safety requirements of the ATX 12V specifications.

5-5-3 Keyboard Controller

The keyboard controller controls all the extended keyboard operations, power management systems and audio control.

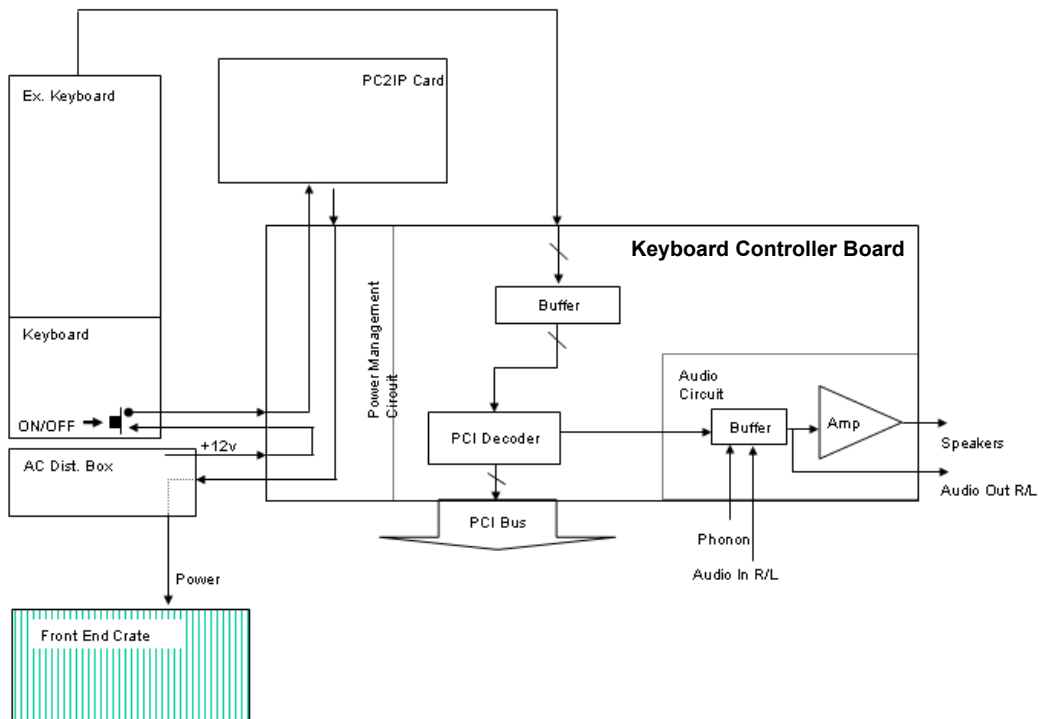

Figure 5-24 Keyboard Controller Block Diagram

The Keyboard Controller contains the Audio Amplifier that controls the volume of the front cover speakers. The Keyboard Controller also contains a power management system to enable three shut-down modes:

- **Hard Shutdown**, by pressing the ON/OFF button continuously for more than 10 seconds. This is for emergencies only and should not be used under regular circumstances.
- **Standby Mode**, which enables system boot-up in 30 seconds (this option is enabled if the Plug & Scan option is installed, allowing you to move the unit from one location to another).
- **Full Shutdown**, which then requires more than 2 minutes to boot up.

There are three main keyboard components:

- **External Keyboard:** All the soft keys, whose functionality changes according to the selected menu.
- **Trackball:** Operates in a similar manner to that of a PC mouse pointer.
- **Alphanumeric Keyboard:** The normal keyboard including the function keys and numbers to enable text writing and other functions.

5-5-4 Multifunction I/O Controller

The Multifunction I/O Controller provides two additional serial COMs, COM3 and COM4, that are used to support the modem functions.

5-5-5 Frame Grabber (RFI systems only)

The Frame Grabber (see [Figure 5-25](#) below) grabs the YC video signal from the VCR Output and converts it to PCI data, allowing the system to present playback images from the VCR recording.

NOTE: This operation was previously handled as a function of the Image Port on Vivid™ 4 systems with the RFT configuration.

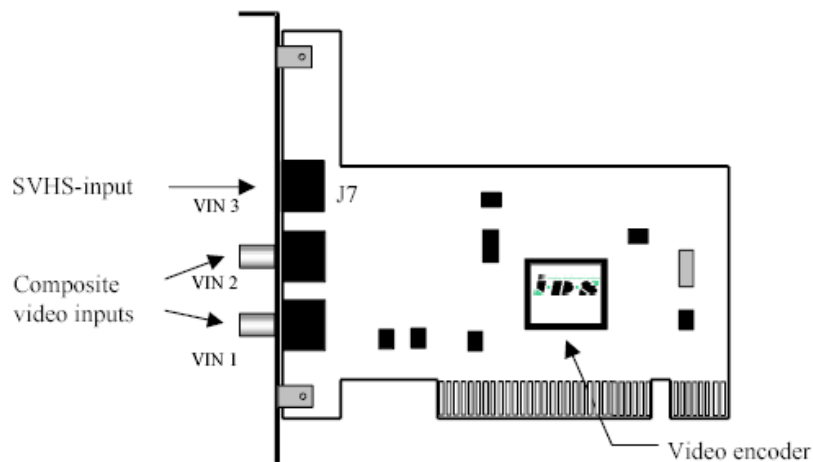

Figure 5-25 Frame Grabber - Vivid™ 4 BT03 Systems with RFI Configuration

5-5-6 PC2IP

The PC2IP enables the transfer and reception of data and control signals between the Front End Crate and the Back End Processor via the Image Port Board. The PC2IP adapts data from the IP to the PCI Bus of the CPU. The PC2IP is sometimes referred to as the PCI Bridge.

5-5-7 Plug and Scan Card and Battery

The Plug Scan enables the Standby Mode during Plug and Scan operations, and performs a legal shutdown of the operating system when the power lines go below preset values. The P&S does not support the operation of the unit during a power failure, but rather enables the shutdown of the Back End Processor to Standby Mode and supports Standby Mode while there is no power supply. The P&S battery degrades with time and should be replaced, as described in [Chapter 10 - Periodic Maintenance](#).

5-5-8 Network Onboard

The Network Onboard enables the Vivid™ 3 to operate in a standard LAN network (EchoPac environment), which enables the system to connect to external applications, saving or retrieval of data from network residents.

5-5-9 SCSI Card

The SCSI Card supports the operation of the MOD. The SCSI Card is situated on the PCI Bus of the CPU, and is controlled by the CPU.

5-5-10 Floppy Drive

The Floppy Drive supports basic data retrieval from the Vivid™ 3 ultrasound unit, such as log files, export to Microsoft Excel, small image files and other service utility operations. The floppy drive is controlled by the CPU via signals from the IDE Bus. The floppy drive can support media format not larger than 1.44 MB size 3.5 in.

5-5-11 Hard Disk

The Hard Disk is the main storage device of the Vivid™ 3 ultrasound unit. The Hard Disk is controlled by the CPU via signals from the IDE Bus. The Hard Disk is partitioned into four drives, each of which is designated for different operations, as follows:

- **C: Drive:** Execution of the operating system and the software application, and factory presets. The partition size 2Gbyte.
- **D: Drive:** User presets and data. The partition size is 1Gbyte.
- **E: Drive:** Archiving of all images and reports. The partition size is normally 15.5Gbyte but this depends upon the size of the hard disk.
- **F: Drive:** Swap file partition for future usage. The partition size is 550Mbyte.

5-5-12 Magneto-Optical Drive (MOD)

The MOD is used to back-up images and reports. Backing up enables storage of the images and reports for future review on Vivid™ 3 ultrasound units, or other EchoPac-compatible devices. The MOD is controlled by the CPU via the SCSI Card. Only 2.3 MB media are EchoPac (DICOM)-compatible with EchoPac devices. Magneto-Optical media of any other size may be used for back-up, but will only be compatible with DICOM.

5-5-13 CD Read Write (CDRW)

The CDRW is used to back-up images and reports, in the similar way as the MOD. In addition, the CD is used as the main source of software upgrades and other service utility operations. The CDRW can write to 24X speed CDs or above, and can read all types of CDs. The CDRW is controlled by the CPU via the IDE Bus.

5-5-14 ECG Module

The ECG Patient I/O module is used to track and convert the ECG signal either via Internal ECG leads or External sources. In addition, the ECG module provides an interface to Microphone input and FootSwitch pedal. The Foot switch is a pass-through to the keyboard functions, while the other functions are communicated to the BEP via the Com2 serial port of the BEP. The Internal leads of the ECG are optically isolated to fit FAD standards.

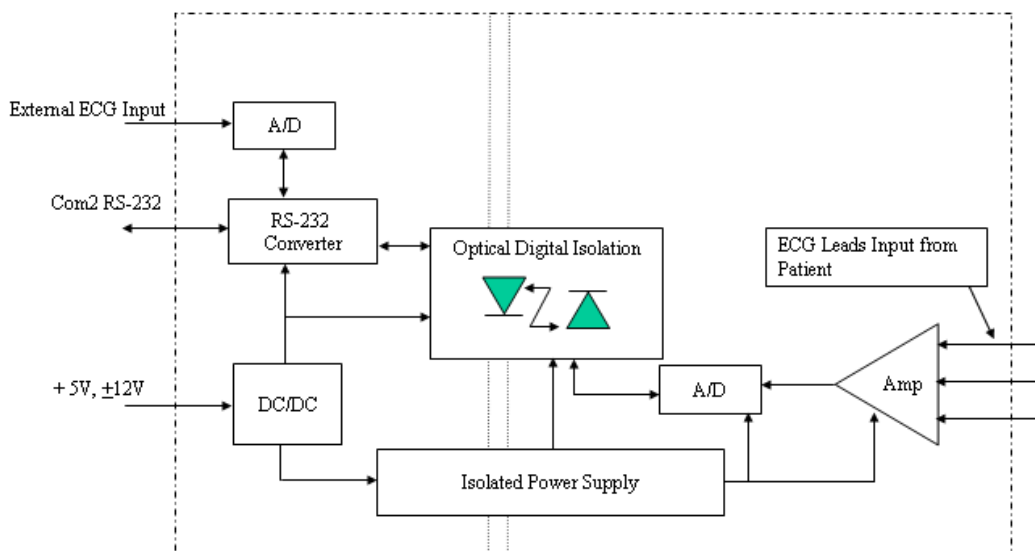

Figure 5-26 ECG Patient I/O Module

5-5-15 Modem

The Modem is a universal modem controlled by the CPU via the USB port. The modem is used for iLinq (InSite) remote servicing. This is a standard MultiTech modem that connects to an analog phone line.

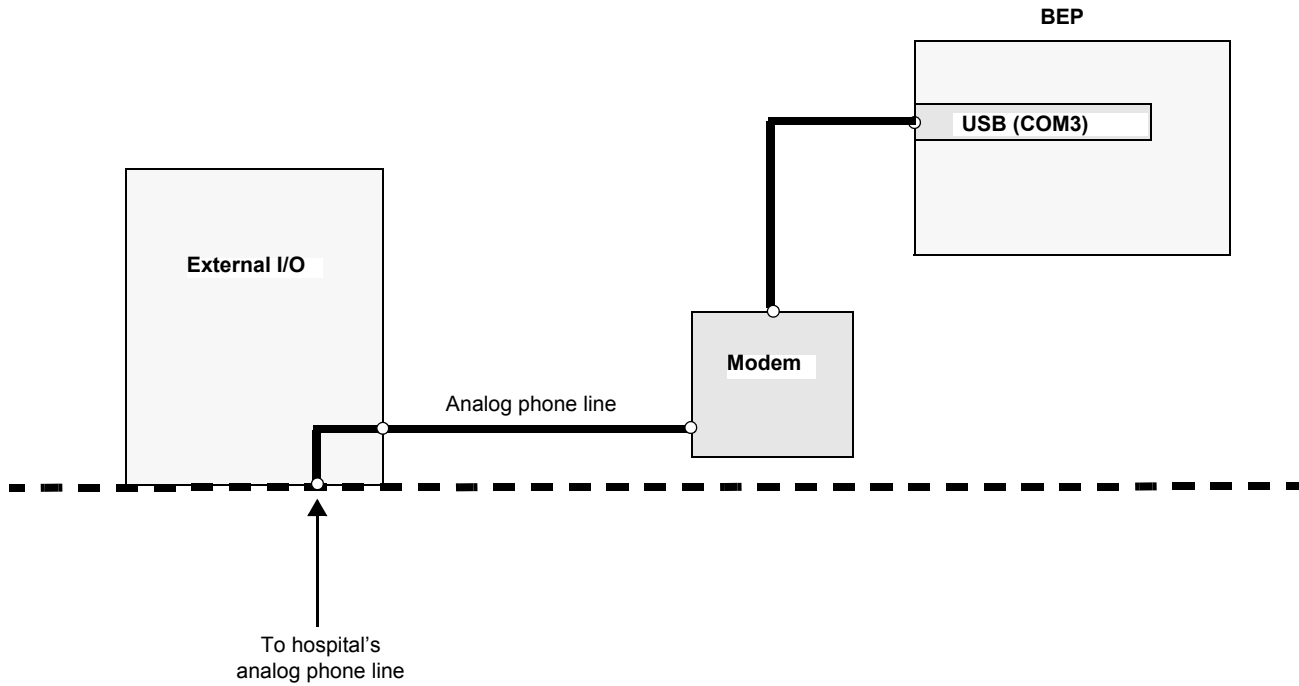

Figure 5-27 Modem Block Diagram

5-5-16 PC-VIC Assembly

5-5-16-1 General Description

The PC-VIC assembly comprises the PC-VIC board and the I/O board.

The I/O board contains inputs and outputs; it receives all input signals, filters them, and transmits them either to another external peripheral or to the PC-VIC board.

The PC-VIC board receives input signals from the VGA board and the PC2IP board. The VGA board transmits SVGA signals which are filtered and transmitted to the Control Console Monitor. The SVGA RGB signals are transmitted into the Video Input and Capturing circuit, where they are conditioned, and only part of the transmitted image is captured and transmitted (in RGB format) to the S-Video C-Video Converter circuit and to the RGB to Color Printer Converter circuit.

The PC2IP board controls the PC-VIC Power-on and also controls the operation of PC-VIC via an I²C signal generated from the PCI bus of the BEP. The I²C signal determines the operation of the Video Input and Capturing circuit and gives the command whether to operate in PAL or NTSC. It also defines which region of the image is to be captured.

The RGB to Color Printer Converter circuit receives an RGB signal from the Video Input and Capturing circuit and converts it to fit the level of RGB Color Printer standards.

The S-Video C-Video Converter circuit receives an RGB signal from the Video Input and Capturing circuit and converts it into S-Video C-Video and sends a feedback signal to the Video Input and Capturing circuit.

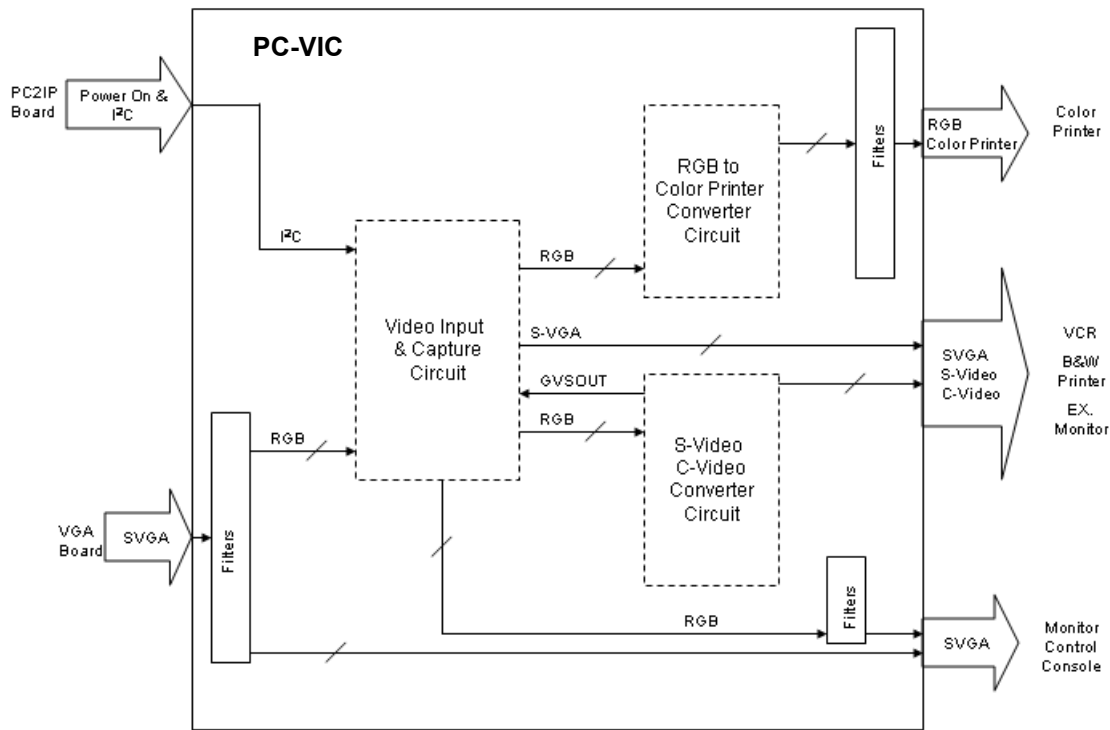

Figure 5-28 PC VIC Block Diagram

5-5-16-2 PAL

Table 5-7 PAL Video Specifications

Horizontal Timing		
Horizontal Total (HT)	us	944 pixels
Horizontal Start (HS)	us	152 pixels
Horizontal Active (HA)	us	768 pixels
Pixel Clock Freq	14.7 MHz	(PAL)
Vertical Timing (Interlaced)		
Vertical Start (VS)	53 Lines / field	
Active Lines (VA)	Lines / frame	(=PAL standard)
Total Lines (VT)	625 Lines / frame	(=PAL standard)
Frame Rate	25Hz	(=PAL standard)

5-5-16-3 NTSC

Table 5-8 NTSC Video Specifications

Horizontal Timing		
Horizontal Total (HT)	us	780 pixels
Horizontal Start (HS)	us	118 pixels
Horizontal Active (HA)	us	640 pixels
Pixel Clock Freq	12.272725 MHz	(NTSC)
Vertical Timing (Interlaced)		
Vertical Start (VS)	17 Lines / field	
Active Lines (VA)	(525 - 17) Lines / frame	(=NTSC standard)
Total Lines (VT)	525 Lines / frame	(=NTSC standard)
Frame Rate	30Hz	(=NTSC standard)

Section 5-6 External Peripherals

5-6-1 Introduction

The following external peripherals are used with the Vivid™ 3 ultrasound scanner:

- VCR (connected to Internal I/O)
- Black & White Video Printer (connected to Internal I/O)
- Color Video Printer (connected to BEP - D5)
- Color Inkjet Printer

5-6-1-1 VCR

The VCR operation is controlled from the Control Console, by way of the Keyboard Controller via COM1. The VCR, which receives and transmits Y/C video signals, is used for recording and re-playing exams. The appropriate type of VCR should be used for the local video signal - PAL or NTSC.

5-6-1-2 Black & White Video Printer

The B&W Video Printer receives a Black and White video signal and a trigger signal, and is controlled via the Control Console.

5-6-1-3 Color Video Printer

The Color Video Printer receives an RGB video signal and a synch signal from the VIC. It is controlled by the Control Console.

5-6-1-4 Color Inkjet Printer

The Color Inkjet Printer is used to print out reports and exams and is controlled via the parallel port of the BEP. In the application software, the color inkjet printer is referred to as the *PC Printer*.

Section 5-7 Vivid™ 3 Power Distribution

5-7-1 Electrical Power

The Vivid™ 3 system can be set up to operate from the following 50/60 Hz AC voltages: 100V, 120V, 220V, 230V and 240V.

The local input voltage is converted to an internal voltage of 230V, via the Trafo. This voltage is distributed to different system components and converted into DC voltages in the BEP and the Front End, to support their operation. [Table 5-9](#) below shows which voltages are used in the various system components, both in the BEP and the Front End.

Table 5-9 Vivid™ 3 - DC Voltage Distribution

End F = Front B = Back	Board / Unit	+3.3V Dig	+5V Dig	+5V Ana	+12V TEE	-5 V Vee	10 V	+15V -15V	Pmx85 n Pmx85 p	±80 V ±40 V	5 V BE	12 V BE	Local 42V LVPS	230V AC Int	Local AC Voltage	3.3V BE
F	Mother Board		+	+	+	+	+	+	+	+						
F	Probes			+					+							
F	F Board			+		+	+	+	+	+						
F	MUX Card		+	+		+	+	+	+	+						
F	BF	+	+		+	+										
F	FEC	+	+			+										
F	RFT		+			+										
F	IMP		+			+										
F	RFI	+	+			+										
B	KB Controller												+			
B	KB Matrix											+	+			
B	VIC										+	+				
F	DC LVPS										+	+		+		
F	TXPS													+		
	Peripherals														+	
	Display														+	
F	Fans												+			
B	Analog Keyboard										+	+				
B	BE										+	+		+		+

5-7-2 AC System

The AC System (see [Figure 5-30](#)) comprises the following components:

- **AC Isolation Transformer.**
- **AC Distribution Box**, as described in [AC Distribution Box](#) on page 5 - 45.
- **AC Input Box**, see [AC Input Box](#) on page 5 - 45.
- **Thermal Fuses**, see [Thermal Fuses](#) on page 5 - 45.

Refer to [Figure 5-29](#) below for RFI-configured systems; for RFT-configured systems, see [Figure 5-30](#) on page 5-44.

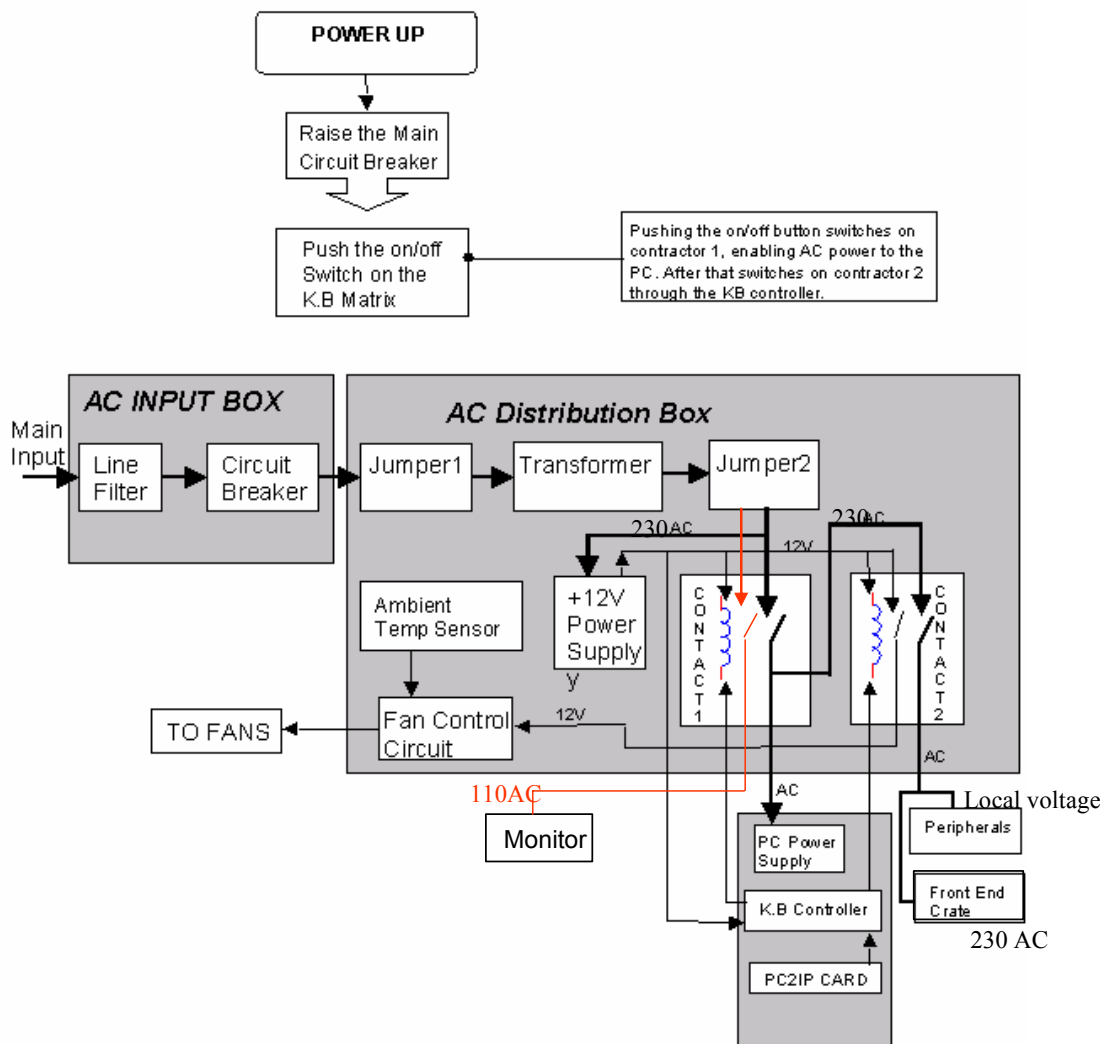

Figure 5-29 AC System Block Diagram - RFI Configuration

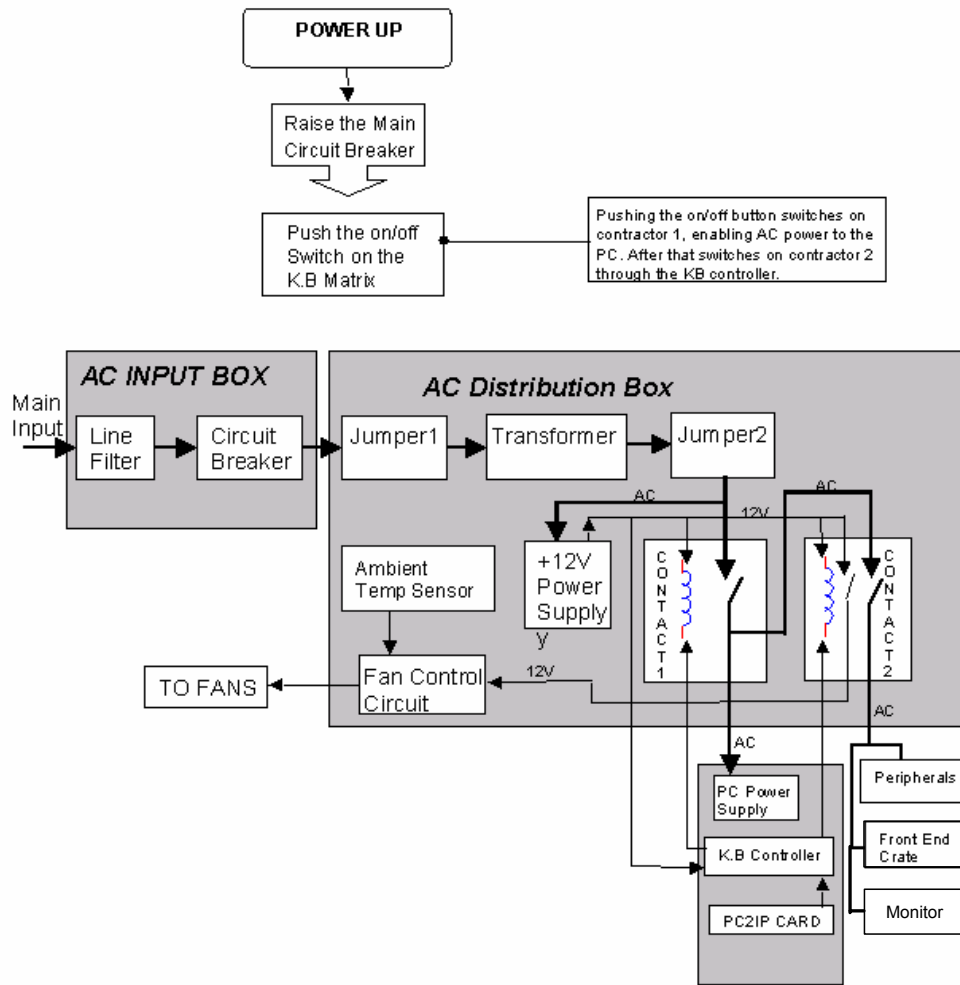

Figure 5-30 AC System Block Diagram - RFT Configuration

5-7-3 AC Distribution Box

The AC Distribution Box contains an electronic board that selects the proper Input and Output system AC voltages, the load connectors, and the low voltage 12 V power supply. In addition, the AC Distribution Box controls the soft AC Start Circuit, the temperature sensor and the Fan Control Circuit.

Note: The cable to the fans also carries a playback video signal from the VCR to the Image Port.

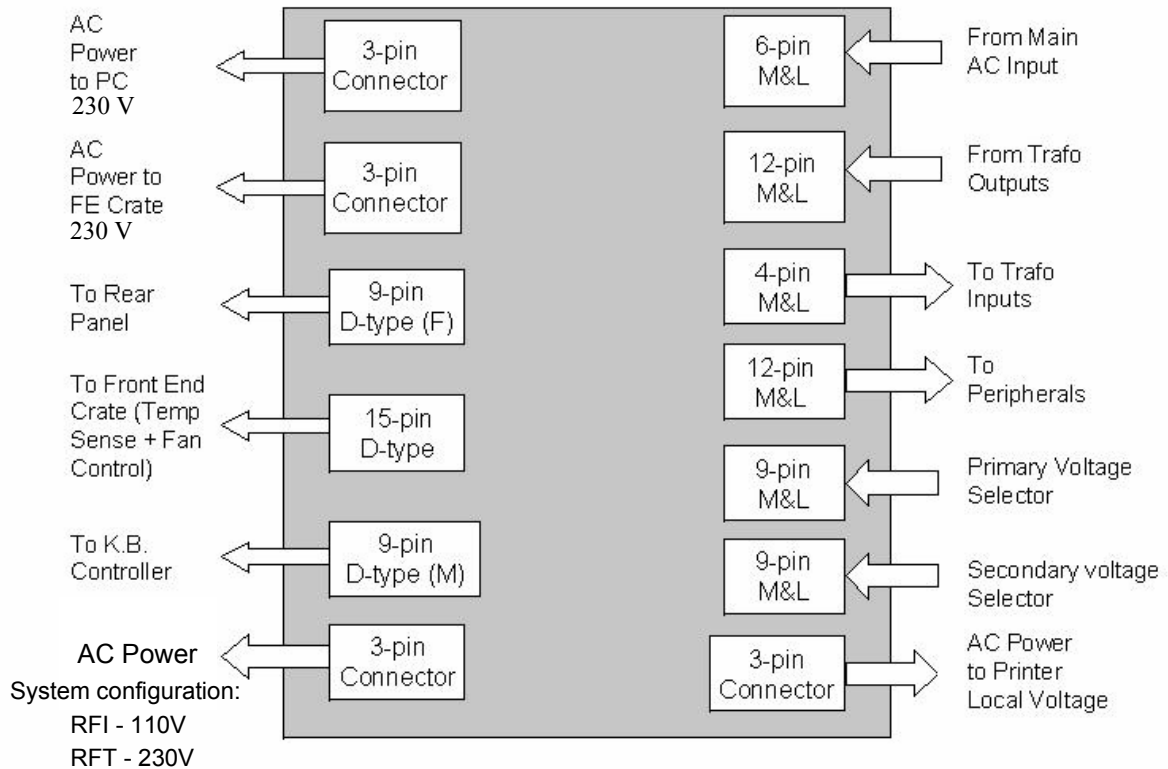

Figure 5-31 AC Distribution Box Connectors Block Diagram

5-7-3-1 AC Input Box

The AC Voltage Input cord is connected to the AC Input Box. It contains the Dual Rating Circuit Breaker 6A - 200 - 240V or 12A 100 - 120V.

5-7-3-2 Thermal Fuses

The system has three internal AC thermal fuses. One is connected to the secondary coil of the transformer, and supplies 230V to the system. The other two fuses are connected to the two coils that supply the local voltages (100V, 120V, 220V-230V or 230V-240V). The coils are connected in parallel to the local voltage configuration.

The thermal fuses are located on the left rear panel.

5-7-3-3 Input AC Voltage Configuration

- The Internal Vivid™ 3 voltage is 220 V AC.
- Back End and Front End Crates operate on 220 V AC.
- The Monitor and Peripherals operate on local voltage.
-

The AC input voltage is factory preset in accordance with specific requirements, as indicated on the label near the AC input connector. The AC transformer's primary and secondary voltages are set up by using the appropriate plugs connected in Jumper1 and Jumper2 on the AC Distribution Box, according to the following table:

Table 5-10 Primary and Secondary AC Voltage

Jumper 1 PRIMARY	Voltage Range	100-120V	220-240V		
	Plug P/N	2253054	2253056		
Jumper 2 SECONDARY	Voltage	100V	120V	220-230V	220-240V
	Plug P/N	2253057	2253058	2253059-2	2253060-2

NOTE: *The AC input voltage power cord and its plug must meet the local standard requirements.*

5-7-4 Front End DC Power Distribution

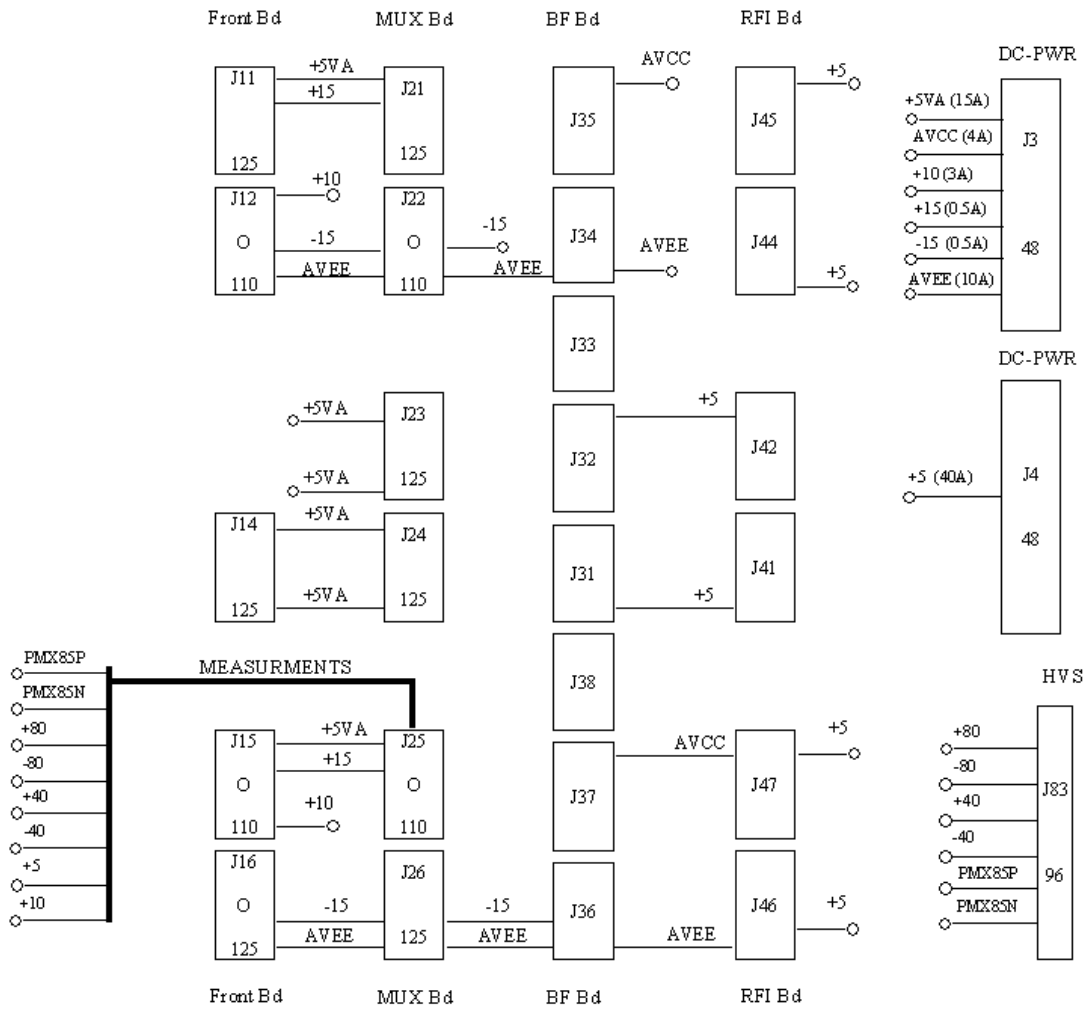

Figure 5-32 DC Distribution: Front End Crate (Vivid™ 4 Systems with RFI Configuration)

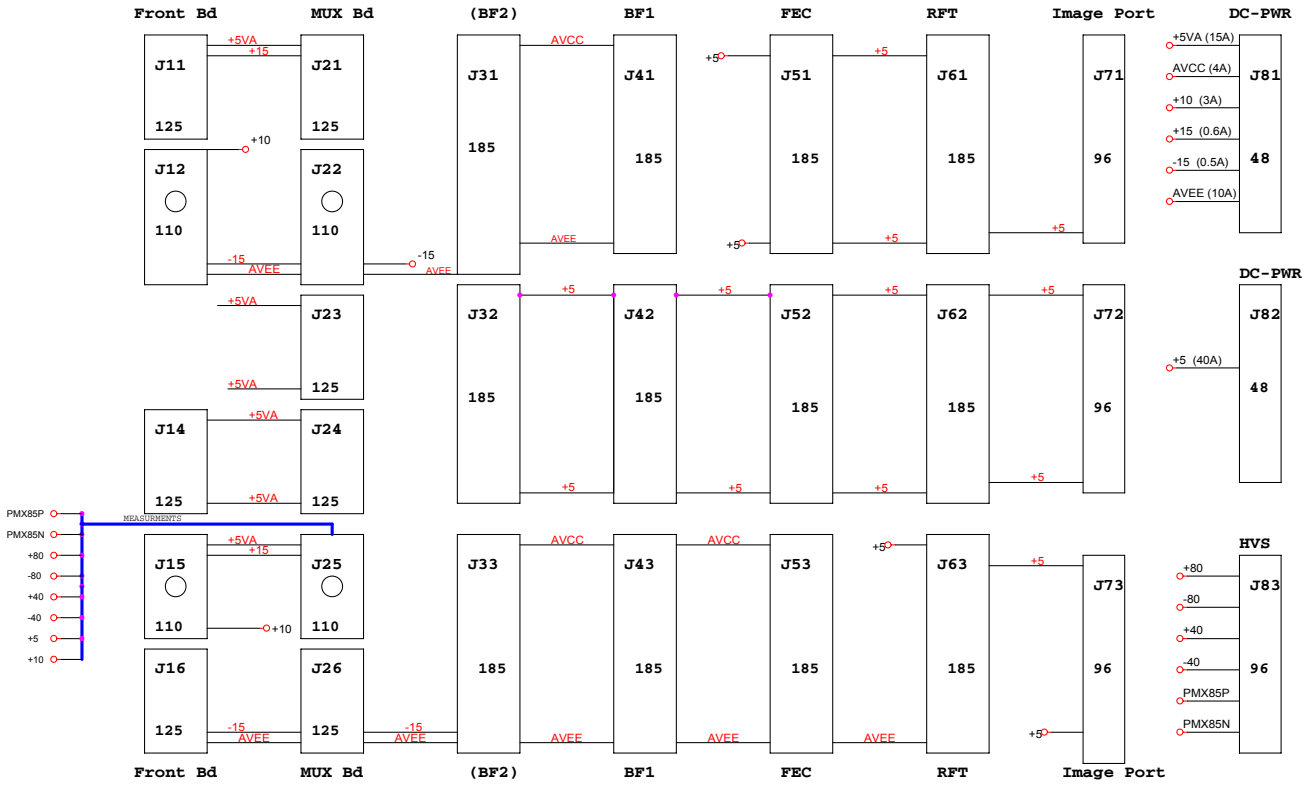

Figure 5-33 DC Distribution: Front End Crate (Systems with RFT Configuration)

Section 5-8 Front End Cooling System

5-8-1 General Description

The Vivid™ 3 Front End cooling system includes following components:

- Dust Filter
- Fans

Other components that have an influence on the airflow is the Front End itself. Air is sucked from the inside of the system through the Filter Cover and the Filter. It passes the Fan Assembly, directly into the upper part of the Front End where it forms a cooling air current between the Boards, before being blown out against the floor. See [Figure 5-34](#).

5-8-2 Location in the Unit

The Fan Assembly is located on top of the Front End Crate.

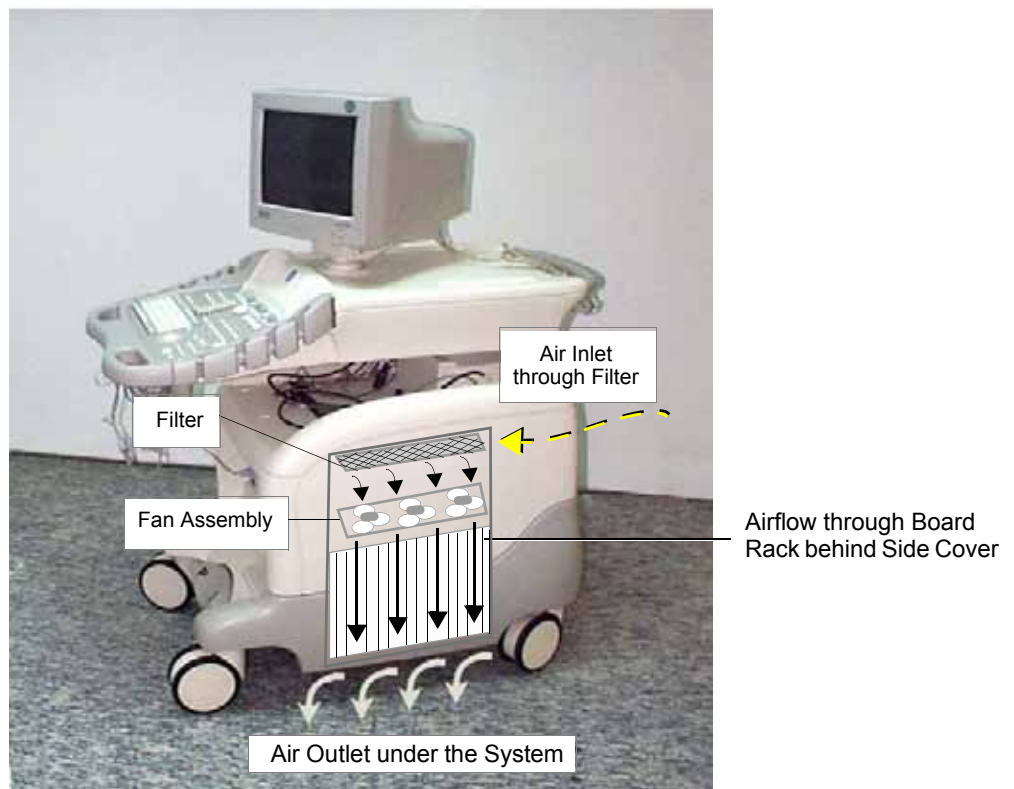

Figure 5-34 Airflow through the Vivid™ 3 System

Section 5-9 Common Service Platform

5-9-1 Introduction

The Service Platform contains a set of software modules that are common to many of GE's ultrasound and cardiology systems. This web-enabled technology provides linkage to e-Services, e-Commerce, and the iCenter, making GE's scanners more e-enabled than ever.

5-9-2 *iLinq* Interactive Platform Features

Many of the services of the Common Service Platform come from its integration with *iLinq*. The following sections contain a brief introduction of *iLinq*'s features.

5-9-2-1 Web Server/Browser

The Service platform and other Service software use the *iLinq* web server and browser.

5-9-2-2 Connectivity

This feature provides basic connectivity between the scanner and the OnLine Center (OLC).

5-9-2-3 Configuration

This feature provides the interfaces to configure various *iLinq* parameters.

5-9-2-4 Contact GE

Allows a one-switch touch for the user to contact the OnLine Center and describe problems with their scanner in an easy and convenient way.

5-9-2-5 Interactive Application

The main application is displayed in the form of HTML pages whenever the browser starts. This is the entry point for any user to start any *iLinq* application.

5-9-3 Global Service User Interface (GSUI)

GSUI is the pattern for the user interface. This interface standard will be followed by all modalities to achieve a common look-and-feel for service software across all GEMS products.

5-9-3-1 Internationalization

The user interfaces provided by the service platform are designed for GE personnel and, as such, are in English only. At this time, there is no multi-lingual capability built into the Common Service Interface.

5-9-3-2 Service Login

Press the switch with the wrench icon () in the status bar at the bottom of the video screen.

This switch links the user or the Field Engineer (FE) to the service login screen.

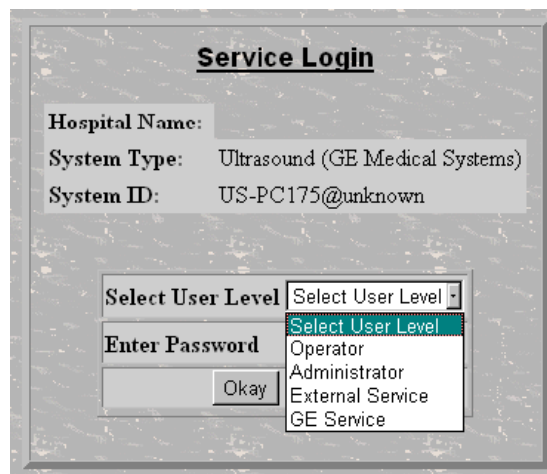

Figure 5-35 Service Login Screen

5-9-3-3 Access / Security

The service interface has different access and security user levels. Users are only granted access to the tools they are authorized to use.

Table 5-11 Access Authorization

User Level	Access Authorization
Operator	These service tools are normally used in-house and are protected with a password.
Administrator	Use the OnLine Center access method provided by <i>iLinq</i> .
External Service	Access is protected with a password.
GE Service	Requires knowledge of a password.

A modem on the scanner is specifically intended for *iLinq* use (by the user) and for InSite use.

Every access request, whether successful or not, will be logged into a service access log that is viewable to authorized users.

See [Chapter 7 - Diagnostics/Troubleshooting](#) for more info about InSite and the Global Service User Interface.

Chapter 6

Service Adjustments

Section 6-1 Overview

6-1-1 Purpose of Chapter 6

Table 6-1 Contents in Chapter 6

Section	Description	Page Number
6-1	Overview	6-1
6-2	Input AC Voltage Configuration	6-2
6-3	Front End Voltages and Signal Indicators	6-3
6-4	Back End Power Supply Voltages	6-8
6-5	VIC Video Signal Setting	6-8
6-6	Monitor Operation	6-9
6-7	Image Quality Calibration	6-12
6-8	Calibration	6-14

Section 6-2 Input AC Voltage Configuration

- The internal Vivid™ 3 voltage is 220V AC.
- The Back End and Front End Crates operate on 220V AC.
- The Monitor and Peripherals operate on local voltage.

6-2-1 Secondary Voltage Configuration

The AC input voltage is factory preset according to specific requirements, as indicated on the label near the AC input connector. The AC transformer's primary and secondary voltages are set up by using the appropriate plugs connected in Jumper1 and Jumper2 on the AC Distribution Box, in accordance with the information in [Table 6-2](#) below:

Table 6-2 Primary and Secondary AC Voltages

Jumper 1 PRIMARY	Voltage Range	100-120V	220-240V		
	Plug P/N	2253054	2253056		
Jumper 2 SECONDARY	Voltage	100V	120V	220-230V	230-240V
	Plug P/N	2253057	2253058	2253059-2	2253060-2

6-2-2 AC Input Cord

The input voltage power cord and plug must meet the local standards and requirements.

Section 6-3 Front End Voltages and Signal Indicators

The majority of the boards in the Front End Crate have red, green and yellow LEDs, which indicate the board's status as follows:

- **Red LED Lit:** An error has occurred on the board (unless otherwise specified).
- **Yellow LED Lit:** Software defined.
- **Green LED Lit:** The board is functioning properly.

For RFI-configured systems, see [Figure 6-1](#) below. Refer to [Figure 6-2](#) on page 6-4 for systems with the RFT hardware configuration.

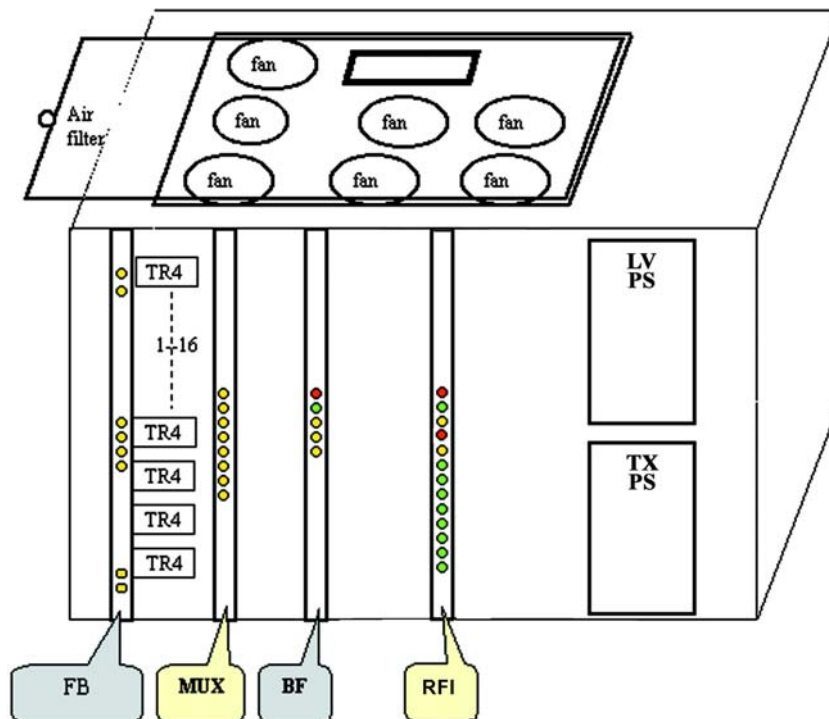

Figure 6-1 Front End Crate LEDs - RFI Configuration

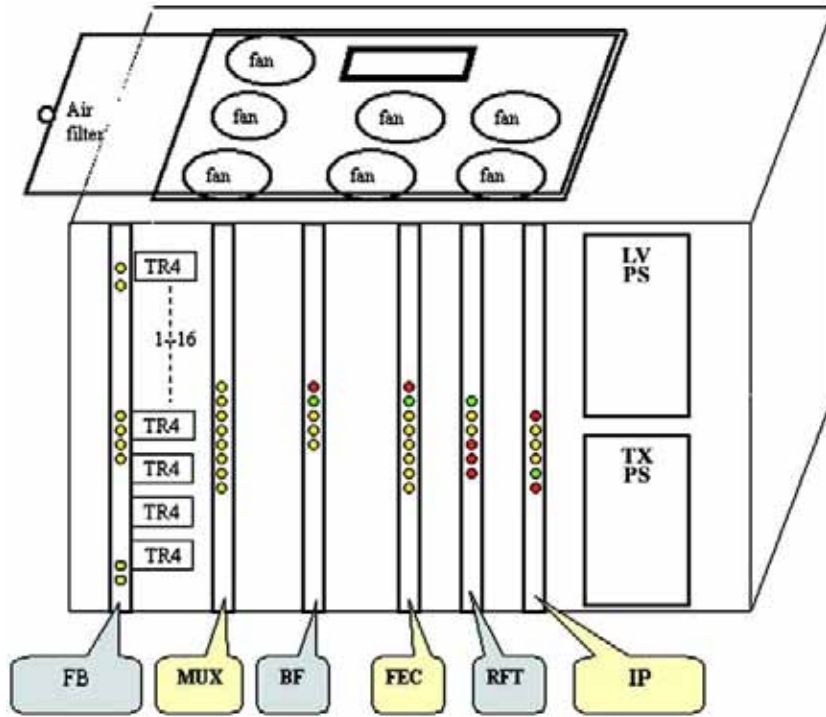

Figure 6-2 Front End Crate LEDs - RFT Configuration

The LEDs for each of the boards in the Front End Crate are summarized in the following subsections. The LEDs are listed as viewed from the top of the board, when positioned in the Front End Crate.

Note: The front end voltages can be measured at the front of the Front Board (FB) using the voltage test points.

6-3-1 RFI LEDs

Table 6-3 RFI - LEDs

LED #	LED Color	Description	Normal State
LD505	■ - Red	Demod Error	
LD504	■ - Green	Lit in Scanning Mode	Slow tick in idle
LD503	■ - Yellow	Transmit data to BEP	During Processing
LD502	■ - Red	Not Used	
LD501	■ - Yellow	Not Used	
LD500	■ - Green	Not Used	
LD12	■ - Green	5.0 V status	
LD22	■ - Green	-2.0 V status	
LD11	■ - Green	1.4 V status	
LD10	■ - Green	1.5 V status	
LD9	■ - Green	3.3 V status	
LD8	■ - Green	-5.0 V status	
LD7	■ - Green	2.5 V status	

6-3-2 Image Port (IMP) LEDs

Table 6-4 Image Port LEDs

LED	Indicates When Lit	Comments
Red	Board Failure	Normally ON
Yellow		
Yellow	VME Master	Lit during scanning and data transfer
Yellow	VME Slave	
Green	Board OK	Normally lit
Red	Board Failure	Normally OFF

6-3-3 Front End Controller (FEC) LEDs

Table 6-5 Front End Controller LEDs

LED	Indicates When Lit	Comments
Red	Board Failure	Normally OFF
Green	Board OK	Normally lit
Yellow	Scan	Lit during scanning
Yellow	Probe Change	Lit during probe change
Yellow	No Probe	Lit if no probe is selected
Yellow	HV Over Range	Lit if excessive HV is output, possibly due to HV surveillance

6-3-4 RF and Tissue Processor (RFT)

Table 6-6 RF and Tissue Processor LEDs

LED	Indicates When Lit	Comments
Red	Board Failure	Normally OFF
Green	Board OK	Normally lit
Yellow	DSP Runs	Normally blinking
Yellow	Data Out on Pipeline	Lit during data transfer to pipelink
Red	Clock Problems	Normally OFF
Red	Clock Problems	Normally OFF
Red	Clock Problems	Normally OFF

6-3-5 Beamformer (BF)

Table 6-7 Beamformer LEDs

LED	Indicates When Lit	Comments
Red	Board Failure	Normally OFF
Green	Board OK	Normally lit
Yellow	Bus Protocol Error	Normally OFF
Yellow	Scan	Normally OFF
Yellow		

6-3-6 Channels Multiplexer (MUX)

Table 6-8 Channels Multiplexer LEDs

LED	Indicates When Lit	Comments
Green	5V PS is OK	Normally lit
Green	5V PS is OK	Normally lit
Green	5V PS is OK	Normally lit
Green	5V PS is OK	Normally lit
Green	5V PS is OK	Normally lit

6-3-7 Front Board Assembly (FB)

Table 6-9 Front Board Assembly LEDs

LED	Indicates When Lit	Comments
Green	15V LVPS is OK	Normally lit
Green	+15V LVPS is OK	Normally lit
Green	AVee LVPS is OK	Normally lit
Green	AVcc LVPS is OK	Normally lit
Green	+5V Dig LVPS is OK	Normally lit
Green	+10V LVPS is OK	Normally lit
T1	Probe Connector 1	Normally lit
T2	Probe Connector 2	Normally lit
T3	N/A	Normally lit
Green	+15RV LVPS is OK	Normally lit
Green	-15RV LVPS is OK	Normally lit
Green	AVee LVPS is OK	Normally lit
Green	AVcc LVPS is OK	Normally lit

Section 6-4 Back End Power Supply Voltages

The Back End has LEDs located on the Mother Board that can indicate the status of each of the voltages present in the Back End. If measured with a generic digital volt meter on any of the connectors to the media (see Figure 6-3 below), the voltage on the red wire should be 5V, and on the yellow wire +12V.

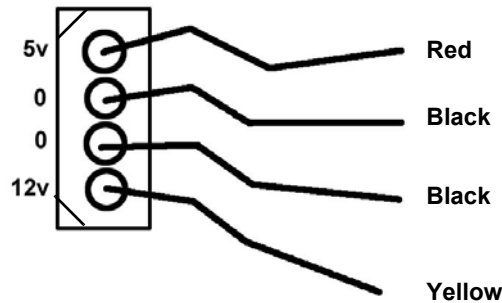

Figure 6-3 Back End Power Supply Voltages

Section 6-5 VIC Video Signal Setting

The Vivid™ 3 ultrasound scanner and VIC may be configured to operate with either PAL or NTSC video systems, as required.

6-5-1 Video Format Confirmation

- 1) Turn ON the system and the check video transmission signal is set correctly.
- 2) Press **Config**.
- 3) From the System Configuration dialog box, select the **VCR/ECG** tab and make sure Either **PAL** or **NTSC** is selected.
- 4) Click the **Technical Support** tab and make sure Frequency is set to either **60Hz** for NTSC, or **50Hz** for PAL.
- 5) Click **OK**.

Note: If the video format is not set correctly, contact an authorized GE Service Representative.

Section 6-6 Monitor Operation

The monitor settings that can be adjusted for the Vivid™ 3 ultrasound unit can be split into two main types:

- **Geometry:** For example, *image size, position, linearity* and so on. The geometry calibration is usually performed once, and rarely requires additional recalibration.
- **Image Quality:** For example, *brightness, contrast and color balance*, as described in the [Image Quality Calibration](#) section, page 6-12.

6-6-1 Vivid™ 3 Samsung 15" and 17" Monitor Operation

NOTE: *The information in this section relates to the new-type Samsung monitors, as follows:*

- Samsung 15" Monitor (SyncMaster 591S; P/N 2336022-2)
- Samsung 17" Monitor (SyncMaster 795MB; P/N 2336835-6)

Most of the adjustments you make to your monitor will be accessed through the on-screen menu described in the next section. The Contrast and Brightness features can also be accessed directly from the front of your monitor, as described in the [Image Quality Calibration for the Vivid™ 3 15" and 17" Samsung Monitors](#) section, page 6-12.

6-6-1-1 On-Screen Menu System

Your monitor has an on-screen menu system, accessed by the buttons on the side of the monitor, that allows you to adjust characteristics of the screen image. Display changes are indicated by on-screen adjustment icons. Some functions have sub-menus.



Figure 6-4 Samsung 15" and 17" Monitor - On-Screen Menu System

Table 6-10 15" and 17" On-Screen Menu Controls and Functions

Legend	Control	Function
1	Menu Button	Opens the On-screen menu. Also used to exit the menu, or return to the previous menu.
2	Adjust Button	Used to highlight and adjust items in the menu.
3	Enter Button	Used to select the On-screen menu.
4	Power Button	Used to turn ON/OFF power to the monitor.
5	Power Indicator	Light glows green during normal operation. Light blinks once as the monitor saves your adjustments.

NOTE: For clarification, the numbers appearing in square brackets in the following steps correspond to the numbers shown in [Figure 6-4](#) and [Table 6-10](#), above.

- 1) Push the menu button [1] to display the main menu and activate sub menus.
- 2) Push the adjustment button [2] to move through the icons and highlight items in the menu. The name of the function will appear on each window.
- 3) Push the menu button [1] to exit and save your changes.

6-6-1-2 15" and 17" Monitor Function Control Options

Table 6-11 Vivid™ 3 15" and 17" Monitor Controls and Functions







Control	Function
	Adjusts the background Brightness (white level) of the screen.
	Adjusts the Contrast level (black level) of the screen.
	A ' Moire ' pattern can appear on your screen, looking like a series of concentric circles or arcs. To eliminate this pattern, use the horizontal moire adjustments.
	A ' Moire ' pattern can appear on your screen, looking like a series of concentric circles or arcs. To eliminate this pattern, use the vertical moire adjustments.
	The Degauss feature will remove color impurities caused by magnetic fields. Do not use the Degauss feature more than once within a 30-minute period. Note: The monitor may buzz momentarily, the image colors may change and the image will jiggle for a few seconds. These effects are normal.
	Use the Recall feature to reset these monitor settings to their original levels: Position, Size, Pincushion, Trapezoid, Parallelogram, Pinbalance, Rotation, Clear Moire. Note: If you have selected "Yes", all settings listed above will be reset. All other settings will remain the same.
	Color temperature is a measure of the 'warmth' of the image colors. The available range is between 5000 to 9300K.

Table 6-11 Vivid™ 3 15" and 17" Monitor Controls and Functions

Control	Function
	Adjust the monitor color setting (Red).
	Adjust the monitor color setting (Green).
	Adjust the monitor color setting (Blue).
	When you adjust the Brightness and Contrast after sRGB mode is selected, sRGB mode exits
	Follow these instructions to adjust the horizontal position of the monitor's entire display.
	Follow these instructions to adjust the vertical position of the monitor's entire display.
	Follow these instructions to adjust the horizontal size of the monitor's entire display.
	Follow these instructions to adjust the vertical size of the monitor's entire display.
	Adjust the pincushion setting when the sides of the display are bowed in or bowed out.
	Adjust the pinbalance setting when the sides of the display are bowed towards the left or right.
	Adjust the trapezoid setting when the top or bottom of the display is too large or small.
	Adjust the parallelogram setting when the display is leaning left or right.
	Adjust the rotation setting when the entire display is tilted left or right.
	Adjust the side pin corner correction when the top or bottom of the display is too large or small.

Section 6-7 Image Quality Calibration

The monitor's image quality settings may need periodic adjustment due to changes in ambient light. They can be adjusted using the **Contrast** and **Brightness** buttons on the front (or side) of the display monitor. As the image quality settings are often adjusted, it is recommended to check - and if necessary recalibrate - these settings on a regular basis.

Note: When the monitor is too dark, and the user attempts to compensate by raising the total gain higher than normal, the resulting image quality may not be optimal.

All display monitor controls, other than the contrast and brightness controls, are factory adjusted for optimum settings and usually do not require further adjustment. The service representative adjusts the display monitor to the user's preference. To adjust controls independently, see the appropriate section below.



6-7-1 Image Quality Calibration for the Vivid™ 3 15" and 17" Samsung Monitors

NOTE: The information in this section relates to the new-type Samsung monitors, as follows:

- Samsung 15" Monitor (SyncMaster 591S; P/N 2336022-2)
- Samsung 17" Monitor (SyncMaster 795MB; P/N 2336835-6)

This section describes how to calibrate image quality related settings for the new-type 15" and 17" monitor on Vivid™ 3 ultrasound systems configured with software version 2.0, or above. The information complements the basic monitor adjustment instructions described in the *Vivid 3 Pro/Vivid 3 Expert User's Manual 2300163-100 Rev. 0*, pages 2-27 and 2-28.

Note: When the system is first switched on, the image may appear to be too dark, or to have too much contrast. The display monitor takes 20 minutes to warm up before it shows its final contrast, brightness, and color hues. Perform screen calibration only after the display monitor has warmed up.

- 1.) With the display monitor menu turned ON, press the  button (to adjust contrast) or the  button (to adjust brightness) on the side of the monitor.
- 2.) Press the arrows button on the side of the monitor to *decrease* or *increase* the selected value (refer to [Figure 6-4](#) on page 6-9).

These recommended settings are stable and do not drift over time, but may vary from monitor to monitor. Adjust these recommended values to meet your specific requirements. For example, cardiac users may prefer greater contrast, in which case set the contrast to 90 or even 100. Radiologists may prefer less contrast, in which case set the contrast to below 80.

Table 6-13 Vivid™ 3 15"and 17" Monitors - Brightness and Contrast Settings

	15" Monitor (in Dark Room)	17" Monitor (in Dark Room)
Brightness	50	50
Contrast	100	80
Red	90	100
Green	90	100
Blue	100	100

Note: If after adjustment brightness is set below 10 or above 90, the monitor should be rejected.

Note: Always perform the calibration in similar lighting conditions to those where the unit will be used. If the unit is to be used in different lighting conditions, perform full calibration in both dark and light conditions. It is suggested that you write down the brightness and contrast settings for both conditions, so that the monitor can be reset to the calibrated values.

- 3.) Press the Exit button twice to close the on-screen menu. The scanning screen is displayed.
- 4.) Perform monitor calibration as described in the [Monitor Calibration](#) on page 6 - 16.

Section 6-8 Calibration

The *Diagnostic* dialog box (accessed by pressing <Ctrl+F11> or <Alt+D>, when in regular scanning mode), enables you to perform three types of calibration, as described in the following sections:

- [Monitor Calibration](#) section, page 6-16.
- [Beamformer Calibration](#) section, page 6-17.
- [Video Grabbing Calibration](#) section, page 6-17.

6-8-1 Accessing the Calibration Options

- 1) Press <Ctrl+F11> (or <Alt+D>) on the alphanumeric keyboard. The *Diagnostic* dialog box is displayed, as shown below:

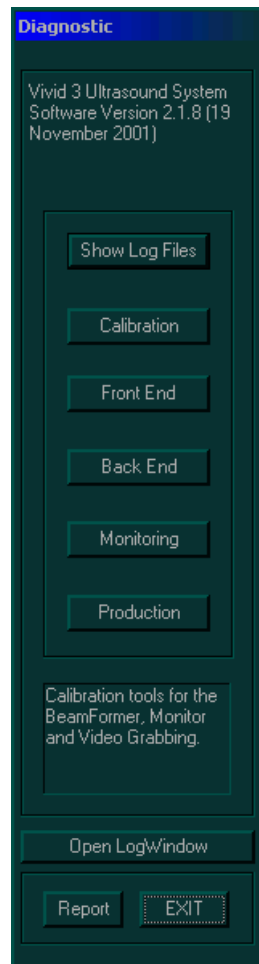

Figure 6-5 Diagnostic Dialog Box

- 2) Trackball to the **Calibration** button and press **Select**. The following calibration options are displayed:



Figure 6-6 Calibration Options

6-8-2 Monitor Calibration

Monitor calibration should be performed after adjusting the image quality settings using the monitor's control buttons, as described in the *Monitor Operation* section, page 6-9.

- 1) Access the calibration options, as described in the *Calibration* section, page 6-14.
- 2) Trackball to the **Display** option and press **Select**. The *Calibration Display* window is displayed, as shown below:

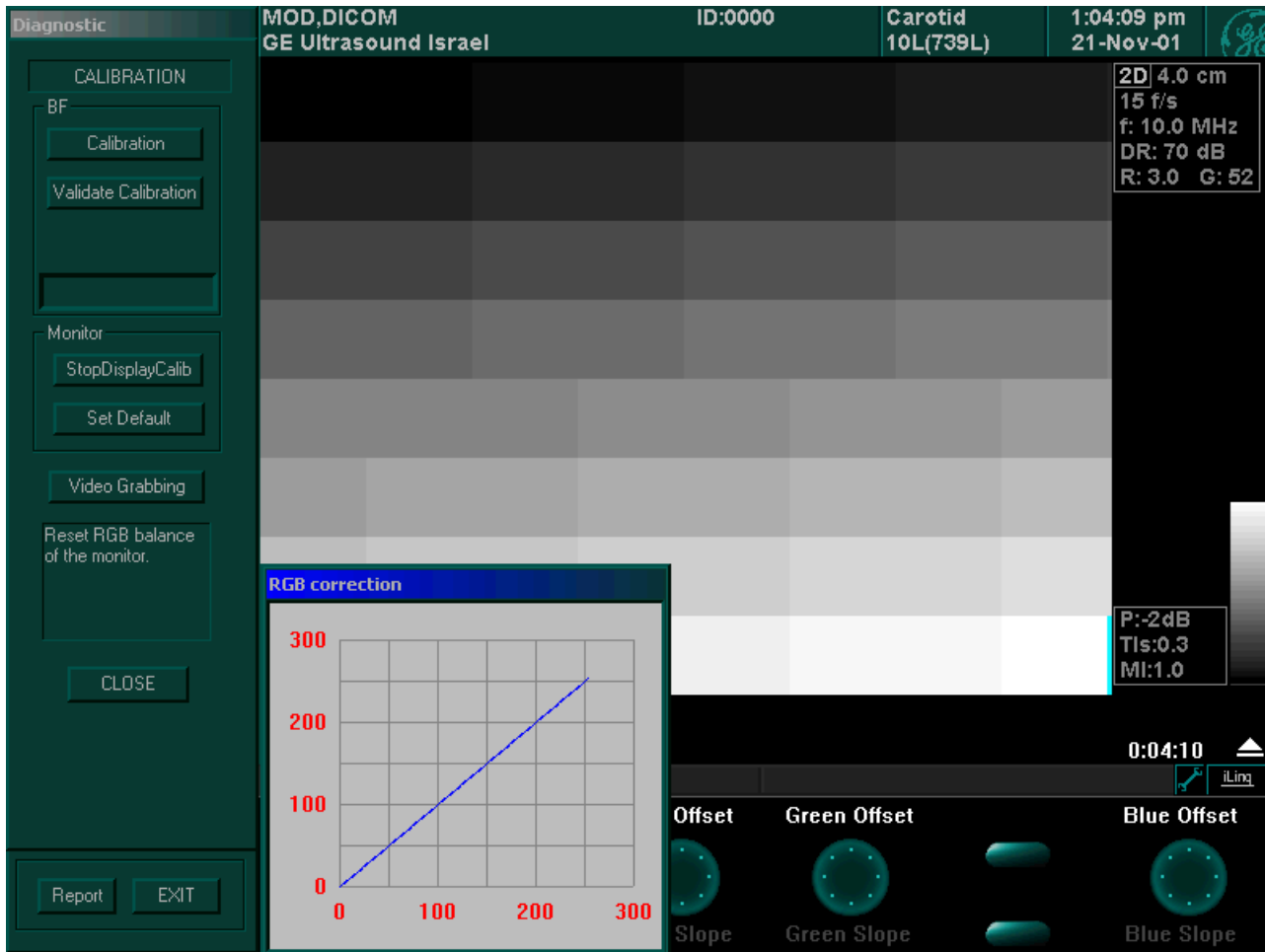

Figure 6-7 Calibration Display Window

- 3) Adjust the brightness of the monitor so that the black square in the upper-left corner of the window is as dark as possible, while a faint border remains visible between that square and the square to its right.
- 4) Rotate the soft key rotaries to offset the red, green and blue colors, to change the grey shades displayed. By default, the *RGB Calibration* window shows one line at 45 degrees (Blue).
- 5) Trackball to the **StopDisplayCalib** button and press select to complete the monitor calibration.

6-8-3 Beamformer Calibration

NOTE: *IMPORTANT - Do not perform BF Calibration after operating in CW or PW scanning modes since validation will fail. Perform the BF Calibration procedure only after 2D scanning mode.*

Beamformer (BF) calibration is performed to calibrate each of the two BF input's ADC channels. The system calibrates the ADC to zero when there is no signal in the input. These bias voltages are stored in the back end. When changing the BFs, swapping the BFs, or changing the hard disk, perform the BF calibration procedure.

- 1) Access the calibration options, as described in the [Calibration](#) section, page 6-14.
- 2) Trackball to the **Calibration** button and press **Select**. The bias voltages for each channel are validated and stored in the back end.

Note: If necessary, Trackball to the **Validation** button and press **Select** to validate the currently saved bias voltages for each channel without performing calibration.

6-8-4 Video Grabbing Calibration

Video Grabbing calibration is performed when the system's Y/C Video Output is connected to the Y/C Video Input.

- 1) Access the calibration options, as described in the [Calibration](#) section, page 6-14.
- 2) Trackball to the **Video Grabbing** button and press **Select**. The *Video Grabbing* window is displayed, as shown below:

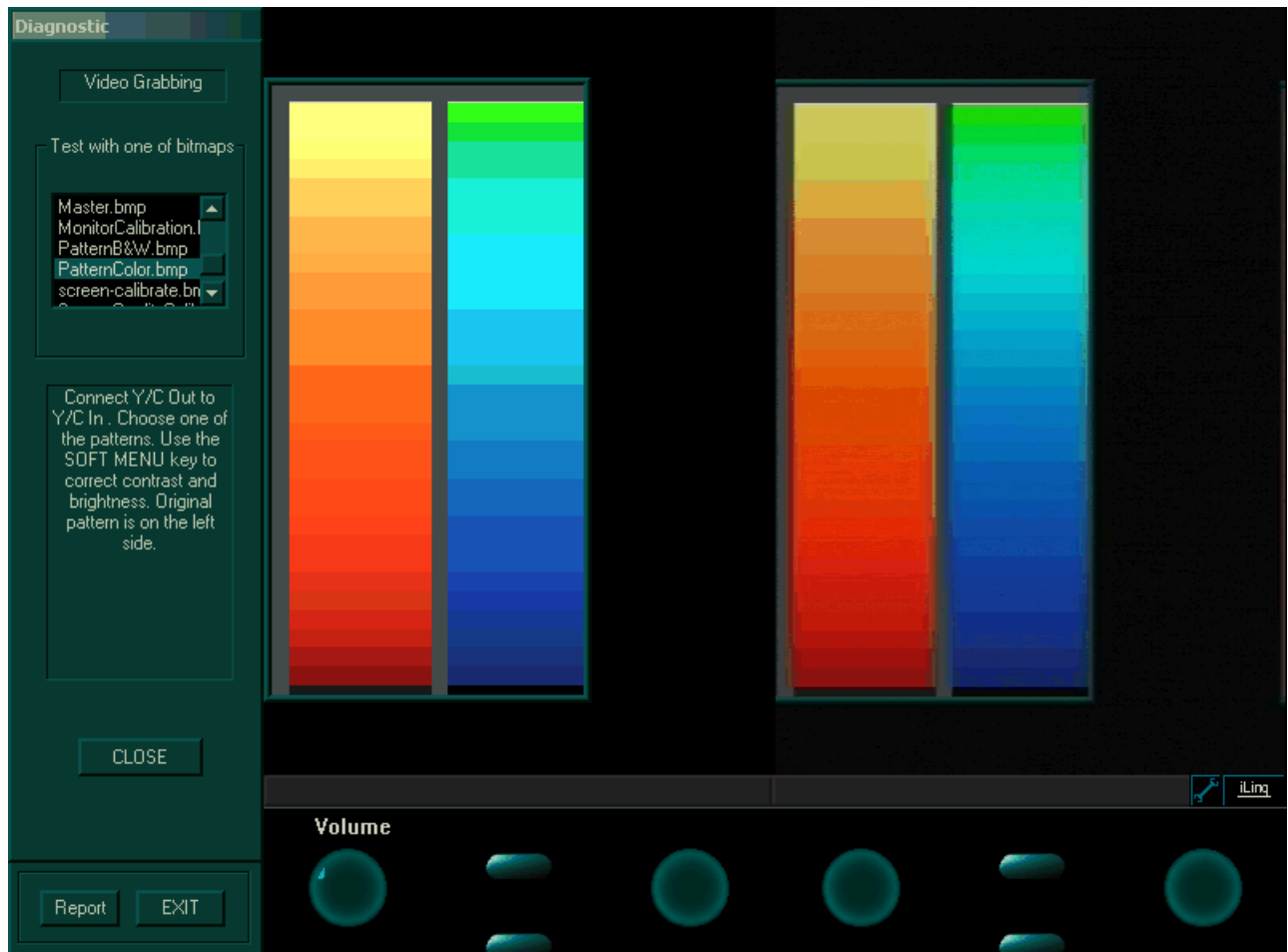

Figure 6-8 Video Grabbing Window

- 3) Connect the Y/C cable from **Video OUT** to **Video IN** on the right rear panel.
- 4) Select the **PatternB&W.bmp** from the **Test with one of bitmaps** area. You will observe the duplication of the selected pattern. This selected pattern is generated by the system and grabbed by the IP card. Compare the two patterns on the screen and ensure that the right side has almost the same quality as the left side.

Note: The video signal path is from the Back-End SVGA board output to the VIC, via the rear panel connector, IP, and then back to the Back End, via the PC2IP cable.

- 5) Select the **PatternColor.bmp**, from the **Test with one of bitmaps** area. You will observe the duplication of the selected pattern. This selected pattern is generated by the system and grabbed by the IP card. Compare the two patterns on the screen and ensure that the right side has almost the same quality as the left side.
- 6) To complete the test, select bitmap **screen calibrate.bmp** and verify the correct image geometry.
- 7) Trackball to the **Close** button and press **Select**.

Chapter 7

Diagnostics/Troubleshooting

Section 7-1 Overview

7-1-1 Purpose of Chapter

This chapter describes how to set up and run diagnostic tools to locate system problems and failures. The Vivid™ 3 ultrasound unit includes built-in diagnostic tools that can be accessed from the scanner application.

Table 7-1 Contents in Chapter 7

Section	Description	Page Number
7-1	Overview	7-1
7-2	Diagnostics	7-2
7-3	Performing Front End (FE) Diagnostics	7-5
7-4	Performing Back End Diagnostics on the System	7-68
7-5	Common Service Interface	7-84
7-6	Automatic Error Log	7-126

Section 7-2 Diagnostics

7-2-1 Diagnostic Tools

The diagnostic tools check the system parts, as well as power supplies, temperature, fan operation, board functions, Back-end signal processing performance, keyboard operation, and so on.

7-2-2 Diagnostic Procedure Summary

The diagnostic tools are used to identify and correct problems as follows:

- When the system boots up, it loads all the required drivers and establishes communication with the front board, via the IP card. Check the system presets to verify that good unit performance can be achieved.
- When the Back End is operating, you can verify proper voltages and temperatures in the Front End motherboard and in the AC Distribution Box. To check the Front End parts, the tests must follow a logical sequence, in order to identify the faulty component. For example, testing communication between the Front End and the Back End begins by testing the RFI board (IMP board) and the PC2IP, before testing all the other boards, in the following sequence (as applicable):

For systems with RFI configuration: *RFI board, BF board, FB and MUX board*

OR

For systems with RFT configuration: *VME Bus, FEC, RFT, BF board, FB and MUX board.*

- Many error messages are displayed due to minor changes in calibration that may occur during normal operation. Before performing diagnostic tests, perform calibration, as described in the [Calibration](#) section, page 6-14. If error messages are displayed after performing calibration, perform the Front End diagnostics described in [Performing Front End \(FE\) Diagnostics](#) on page 7 - 5.

7-2-3 Accessing the Diagnostic Menu

The diagnostic tools are accessed from 2D-Mode by simultaneously pressing <Ctrl+F11> on the alphanumeric keyboard. The *Diagnostic* menu is displayed, as shown below:

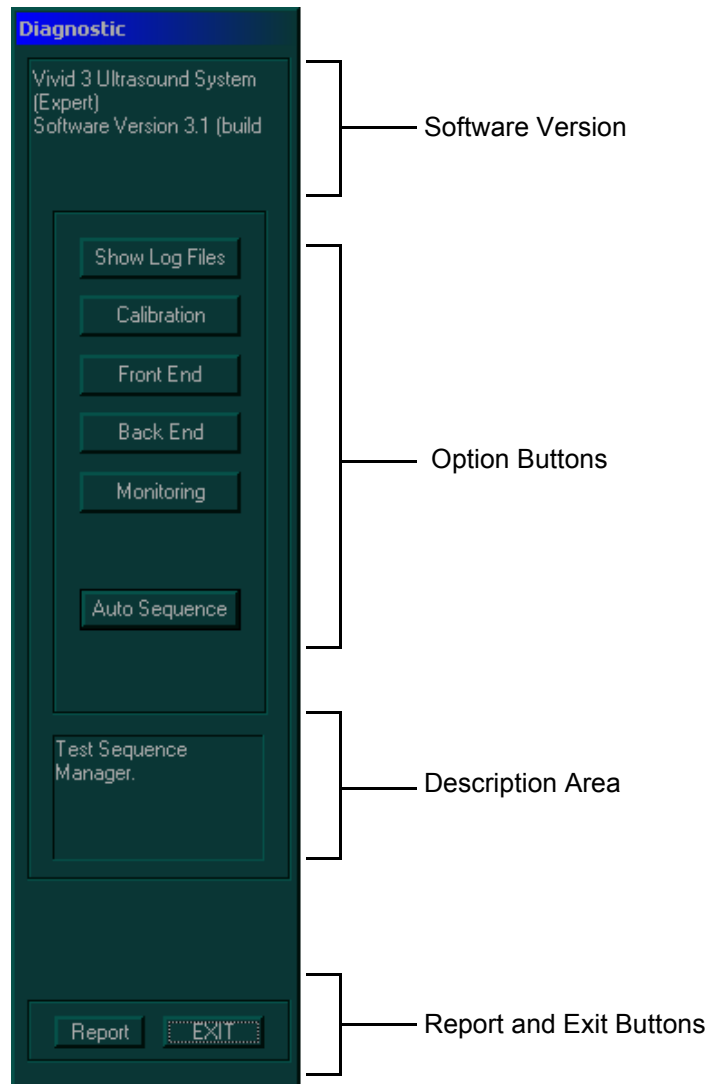

Figure 7-1 Diagnostic Menu

Note: Once the test has been completed, a log can be viewed, as described in the [Common Service Interface](#) section, on page 7-84.

7-2-3-1 Diagnostic Menu Options

The *Diagnostic* menu includes the following options:

- **Software Version:** Displays the Vivid™ 3 ultrasound unit software version number and last upgrade date.
- **Show Log Files** : Displays test results, as described in the [Common Service Interface](#) section, on page 7-84.
- **Calibration** : Calibrates the Front End crate, and enables you to perform the display and video grabbing test, as described in [Calibration](#) on page 6 - 14.
- **Front End** : Tests each board in the Front End crate including the TR power supply, the LVPS supply and temperatures, as described in the [Performing Front End \(FE\) Diagnostics](#) section, on page 7-5.
- **Back End** : Tests various back end hardware components, as described in the [Performing Back End Diagnostics on the System](#) section, on page 7-68.
- **Monitoring** : Monitors all low voltages, Tx voltages, temperatures and AC power input.
- **Auto Sequence** : Performs a full sequence of Front End tests that do not require user intervention. Auto Sequence is particularly recommended for detecting problems that are intermittent in nature, since a test may be paused at any stage and any detected failures reviewed. This is described in the [Auto Sequence](#) section, on page 7-6.
- **Description Area:** Displays a description of the function performed when each of the buttons is selected. Trackball the cursor over a button to display a description in the **Description** area.
- **Report Button:** Displays a current diagnostics report.
- **Exit Button:** Closes the *Diagnostic* menu.

Section 7-3 Performing Front End (FE) Diagnostics

When performing Front End Diagnostics tests, it is strongly recommended to start with **Auto Sequence**, especially if the system shows signs of an intermittent problem. As described in this section, the testing sequence can be paused and restarted at any stage, providing a quick and easy method of reviewing any detected faults.

NOTE: *When using Auto Sequence, most of the FE tests that can be performed manually (refer to the list numbered 1 through 8, below) are automatically performed, in sequence. However the following tests are **NOT** included in Auto Sequence. These should be performed manually, as described in the appropriate sections:*

- Front Board Assembly (FB)
 - Transmit Test
 - TR Switch Test
 - FLA Jumper Test
 - Pencil Probe Test
- MUX Board
 - Advanced Board Tests

NOTE: *During Auto Sequence, the system will automatically re-boot at least twice. This is normal and should not give cause for concern.*

The Front End diagnostic tests listed below can be initiated manually and performed by the system, as described in this section. For each type of system configuration (either RFI or RFT), it is recommended that these diagnostic tests be performed *in the following sequences* (as applicable):

- For systems with **RFI CONFIGURATION**:
 - 1.) **RFI Diagnostic Test**, as described in the [Radio Frequency Interface \(RFI\) Diagnostic Tests \(for RFI Configuration\)](#) section, on page 7-11.
 - 2.) **Beamformer (BF) Diagnostic Test**, as described in the [Beamformer \(BF\) Diagnostic Tests](#) section, on page 7-21. At this stage, to continue to the Front End diagnostic tests, it is necessary to re-boot the system.
 - 3.) **Front Board Assembly (FB) Diagnostic Test**, as described in the [Front Board Assembly \(FB\) Diagnostic Tests](#) section, on page 7-25.
 - 4.) **MUX Diagnostic Test**, as described in the [MUX Diagnostic Tests](#) section, on page 7-47.
 - 5.) **H/W Report Diagnostic Test**, as described in the [H/W Report](#) section, on page 7-66.
- For systems with **RFT CONFIGURATION**:
 - 1.) **Image Port (IMP) Diagnostic Test**, as described in the [Image Port \(IMP\) Diagnostic Tests \(for RFT Configuration\)](#) section, on page 7-13.
 - 2.) **VME Bus (VME) Diagnostic Test**, as described in the [VME Bus \(VME\) Diagnostic Tests \(for RFT Configuration\)](#) section, on page 7-15.
 - 3.) **RFT Diagnostic Test**, as described in the [RFT Diagnostic Tests \(for RFT Configuration\)](#) section, on page 7-17.
 - 4.) **Front End Controller (FEC) Diagnostic Test**, as described in the [Front End Controller \(FEC\) Diagnostic Tests \(for RFT Configuration\)](#) section, on page 7-19.
 - 5.) **Beamformer (BF) Diagnostic Test**, as described in the [Beamformer \(BF\) Diagnostic Tests](#) section, on page 7-21. At this stage, to continue to the Front End diagnostic tests, it is necessary to re-boot the system.
 - 6.) **Front Board Assembly (FB) Diagnostic Test**, as described in the [Front Board Assembly \(FB\) Diagnostic Tests](#) section, on page 7-25.
 - 7.) **MUX Diagnostic Test**, as described in the [MUX Diagnostic Tests](#) section, on page 7-47.
 - 8.) **H/W Report Diagnostic Test**, as described in the [H/W Report](#) section, on page 7-66.

NOTE: *If the system must be re-booted, do so. Continue testing from the point at which you were required to reboot. If a failure occurs, re-boot the system and test again to verify the outcome of the test.*

7-3-1 Accessing the Front End Diagnostic Options

- In 2D-Mode, press <Ctrl+F11> on the alphanumeric keyboard. The *Diagnostic* menu is displayed, as shown in [Figure 7-1](#) on page 7-3.

NOTE: *It is recommended to commence Front End Diagnostic tests using the Auto Sequence option, as described below. To perform tests using the manual options, see [Manual Options](#) on page 7 - 8.*

7-3-1-1 Auto Sequence

- 1.) In the *Diagnostic* menu, trackball to the **Auto Sequence** button and press **Select**. The *Automatic FE Testing* dialog box is displayed, as shown below:

The screenshot shows the 'Automatic FE Testing' dialog box. It has a dark background with light text. The title bar is blue with white text. The dialog is organized into several sections: 'Loops' with an 'Enable' checkbox and a numeric input field showing '2'; 'On Failure' with two radio buttons, 'Stop' and 'Continue', with 'Continue' selected; 'Execute Sequence' with 'Start' and 'Pause' buttons; 'Status' with a 'Test Name' field, 'Loop #' and 'Step #' input fields, 'Passed' and 'Failed' checkboxes, and a progress indicator; and 'View Report' and 'Exit' buttons at the bottom.

Figure 7-2 Automatic FE Testing

- 2.) Select the required number of *Loops* and activate the **Enable** checkbox.
- 3.) Under *On Failure*, activate either the **Stop** or **Continue** checkbox, as required. Stopping on failure enables you to review a failed test, the moment it fails. Alternatively, you may prefer testing to continue on failure and later you may review the report.
- 4.) Under *Execute Sequence*, trackball to the **Start** button and press **Select**.

Auto Sequence commences. While the sequence of automatic testing proceeds, the name of the test currently in progress is displayed in the *Test Name* field and the current *Loop #* and *Step #* are shown below. In addition, a flashing colored light below the *Passed* and *Failed* displays, indicates the current test status, as follows:

- **Green** = test passed
- **Yellow** = test in progress
- **Red** = test failed

- 5.) At any stage, trackball to the **Pause** button (under *Execute Sequence*) and press **Select**, if required.
- 6.) To resume testing (from the point where you paused), trackball to the **Start** button and press **Select**.
- 7.) At any stage during the testing sequence, trackball to the **View Report** button and press **Select** to review the current Auto Sequence Test Report.
- 8.) When Auto Sequence is complete, trackball to the **View Report** button and press **Select** to review the final Auto Sequence Test Report. This will now list all tests performed and show details of which tests passed or failed.
- 9.) Trackball to the **Exit** button and press **Select** to close the *Automatic FE Testing* dialog box.

NOTE: *During Auto Sequence, the system will automatically re-boot at least twice. This is normal and should not be cause for concern.*

7-3-1-2 Manual Options

- 1.) In the *Diagnostic* menu, trackball to the **Front End** button and press **Select**. The *FE Diagnostics* dialog box is displayed, as shown in [Figure 7-3](#) (or [Figure 7-4](#)) below:

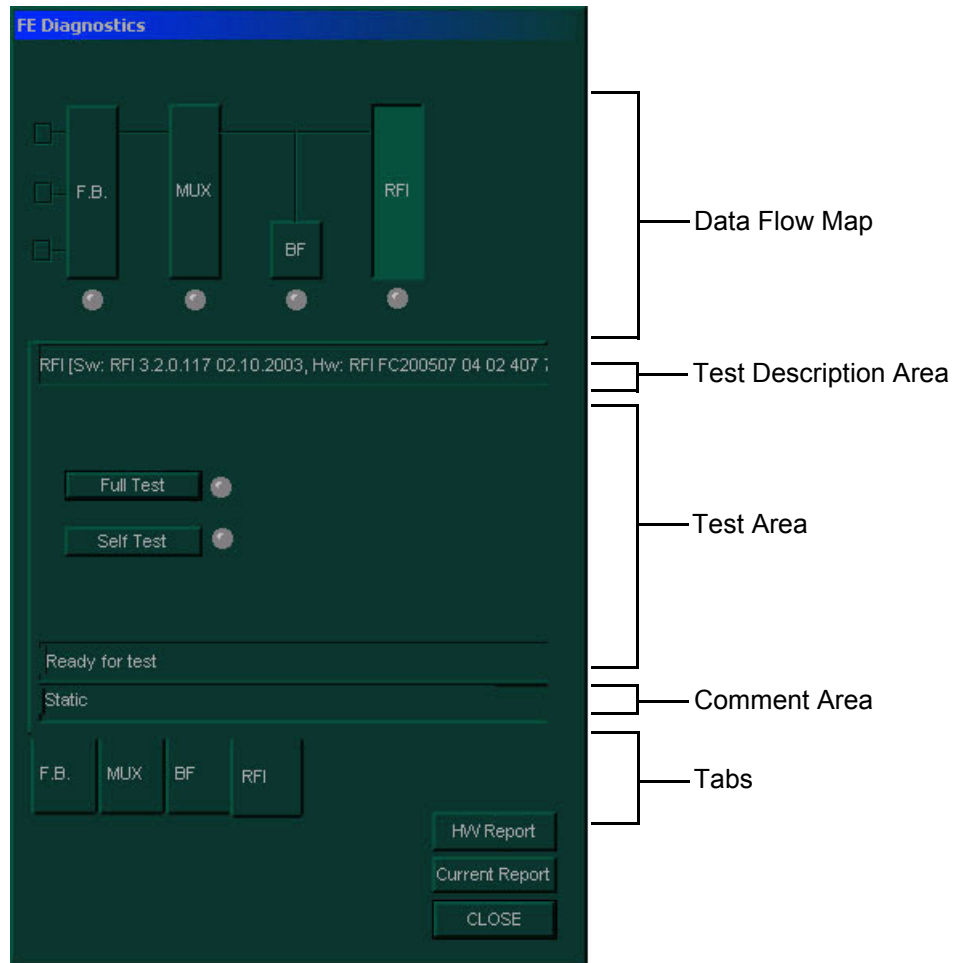

Figure 7-3 FE Diagnostics Dialog Box - RFI Configuration

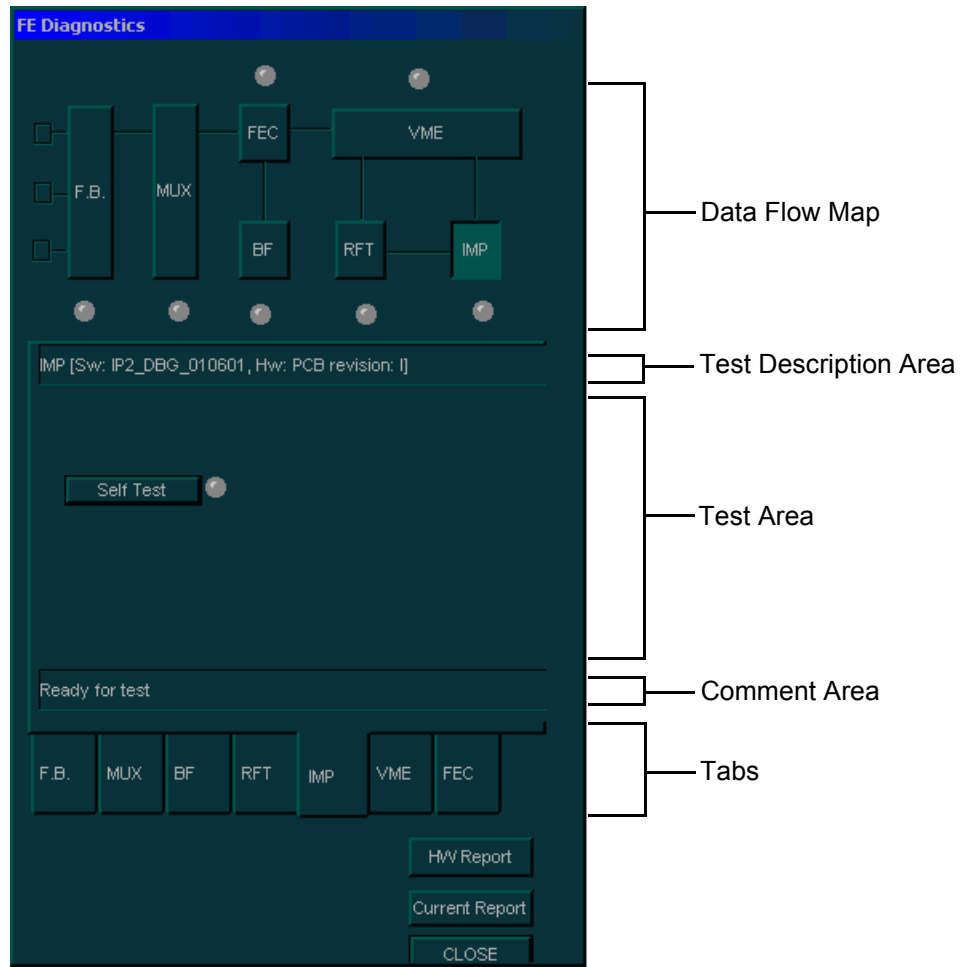

Figure 7-4 FE Diagnostics Dialog Box - RFT Configuration

The *FE Diagnostics* dialog box includes the following options:

Table 7-2 FE Diagnostics Dialog Box Options

Option	Description	Comments
Data Flow Map	Displays a graphic representation of the Vivid™ 3 data flow. The functionality of each button in this area corresponds to that of the tab of the same name in the lower portion of the dialog box. Each button or tab enables you to select and perform the FE diagnostic tests by trackballing to the required button or tab and pressing Select .	Each button has an LED that indicates the following by its color: <ul style="list-style-type: none"> • Green: The test has been completed and no problems were identified. • Red: Problems were identified during the performance of the test. • Yellow: The test is in progress.
Test Description Area	Displays a description of the selected diagnostic test.	
Test Area	Displays the buttons that enable you to perform diagnostic tests.	Each button has an LED that indicates the following by its color: <ul style="list-style-type: none"> • Green: The test has been completed and no problems were identified. • Red: Problems were identified during the performance of the test. • Yellow: The test is in progress.
Comment Area	Displays instructions during the test, as well as test status and result messages.	The following messages are displayed: <ul style="list-style-type: none"> • Test status: For example, Ready for test or Complete • Instructions: During the course of a diagnostic test, any instructions to the user are displayed in the Comment area • Test results: For example, Pass or Fail.
Tabs	Enable you to select and perform the FE diagnostic tests.	
H/W Report Button	Displays hardware and software version information, as described in Chapter 1 - Introduction .	
Current Report Button	Displays the saved error log, as described in the Common Service Interface section, on page 7-84.	
Close Button	Closes the <i>FE Diagnostic</i> dialog box and re-displays the <i>Diagnostic</i> menu.	

7-3-2 Radio Frequency Interface (RFI) Diagnostic Tests (for RFI Configuration)

- 1) Access the *FE Diagnostics* dialog box, as described in the [Accessing the Front End Diagnostic Options](#) section, on page 7-6.
- 2) In the *FE Diagnostics* dialog box, trackball to the **RFI** tab and press **Select**,

The **RFI** tab is displayed, as shown below:

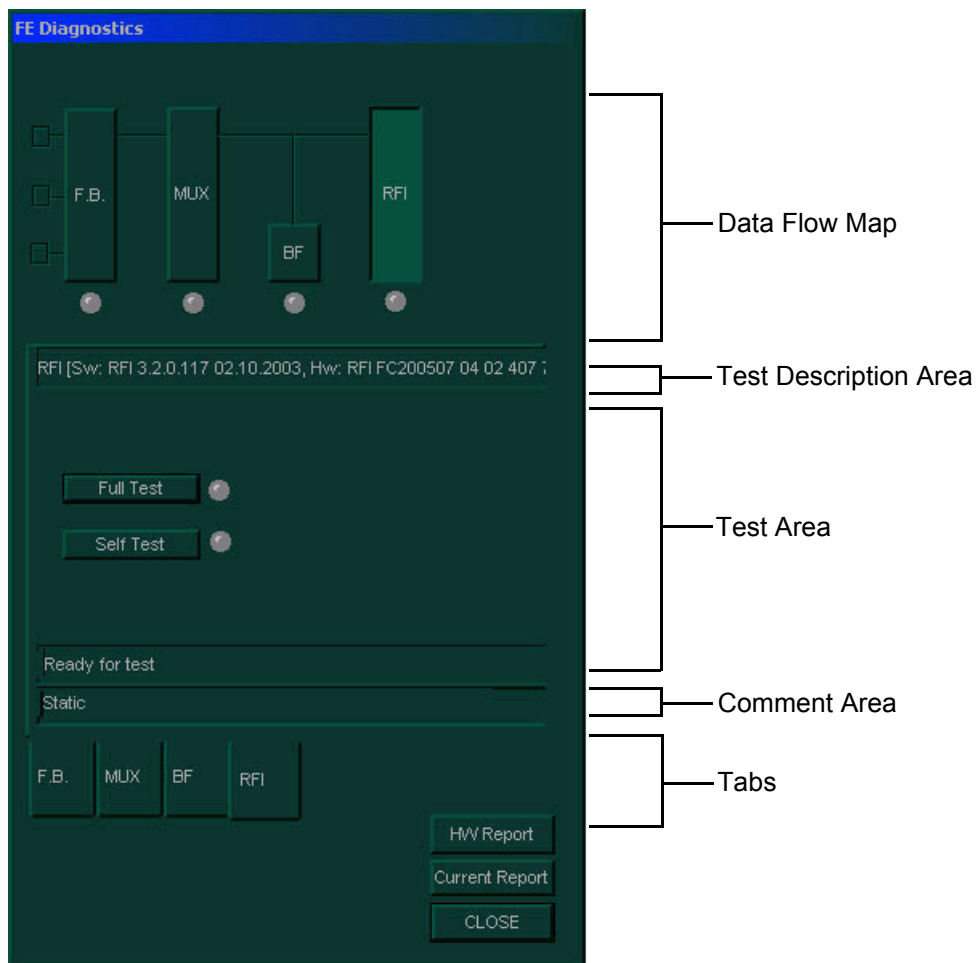

Figure 7-5 RFI Tab - FE Diagnostics Dialog Box

- Note:** Proper operation of the RFI board may be tested by performing either of the two tests: *Self Test* or *Full Test*, as required. (While the Full Test is in progress, it may be necessary to wait a while since this requires longer than the Self Test for completion).
- 3) Verify that the **Comment** area indicates that the system is ready to perform the test (as shown in [Figure 7-5](#), above).
 - 4) Trackball to the **Full Test** tab and press **Select**.

OR

Trackball to the **Self Test** tab and press **Select**.

The **Full Test** (or **Self Test**) LED changes color as follows:

- **Yellow:** The test is in progress.
- **Green:** The test has been completed and no problems were identified.
- **Red:** Problems were identified during the performance of the test.

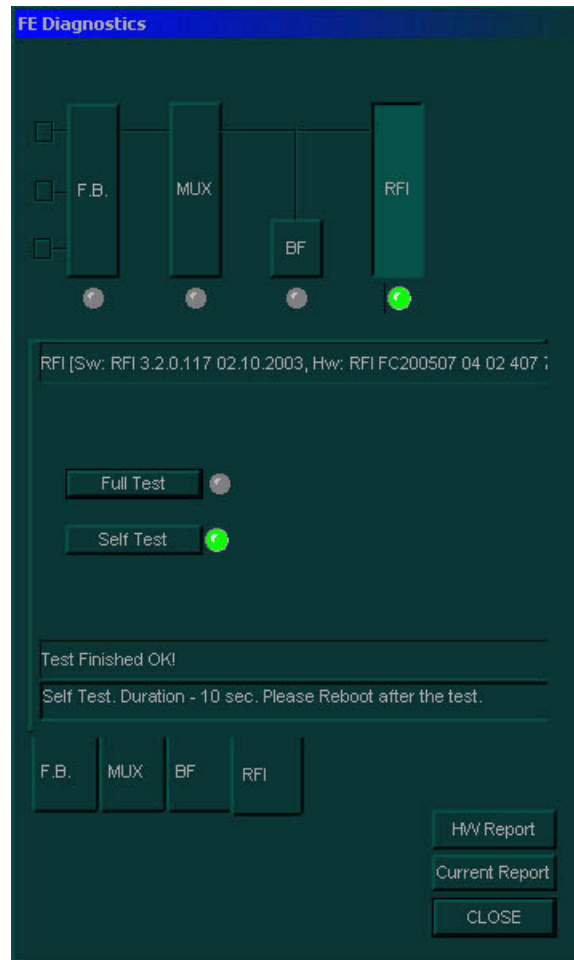

Figure 7-6 RFI Tab - Self Test Complete

- 5) Review the test results in the **Comment** area and proceed as follows:
- If no problems were identified, proceed to re-boot the system, as prompted ([Figure 7-6](#), above).
 - If no problems were identified but the problem persists, contact your local GE Medical Systems field engineer for assistance.
 - If errors were identified but the results were marginal, perform calibration, as described in the [Calibration](#) section, on page 6-14, and then repeat the RFI test.
 - If errors were identified and the results were not marginal, verify that the RFI cables are connected and functioning properly, as described in [Chapter 5 - Components and Function \(Theory\)](#). If the problem persists, contact your local GE Medical Systems field engineer for assistance.

7-3-3 Image Port (IMP) Diagnostic Tests (for RFT Configuration)

- 1) Access the *FE Diagnostics* dialog box, as described in the [Accessing the Front End Diagnostic Options](#) section, on page 7-6.
- 2) In the *FE Diagnostics* dialog box, trackball to the **IMP** tab and press **Select**,

OR

Trackball to the **IMP** button in the **Data Flow Map** and press **Select**.

The **IMP** tab is displayed, as shown below:

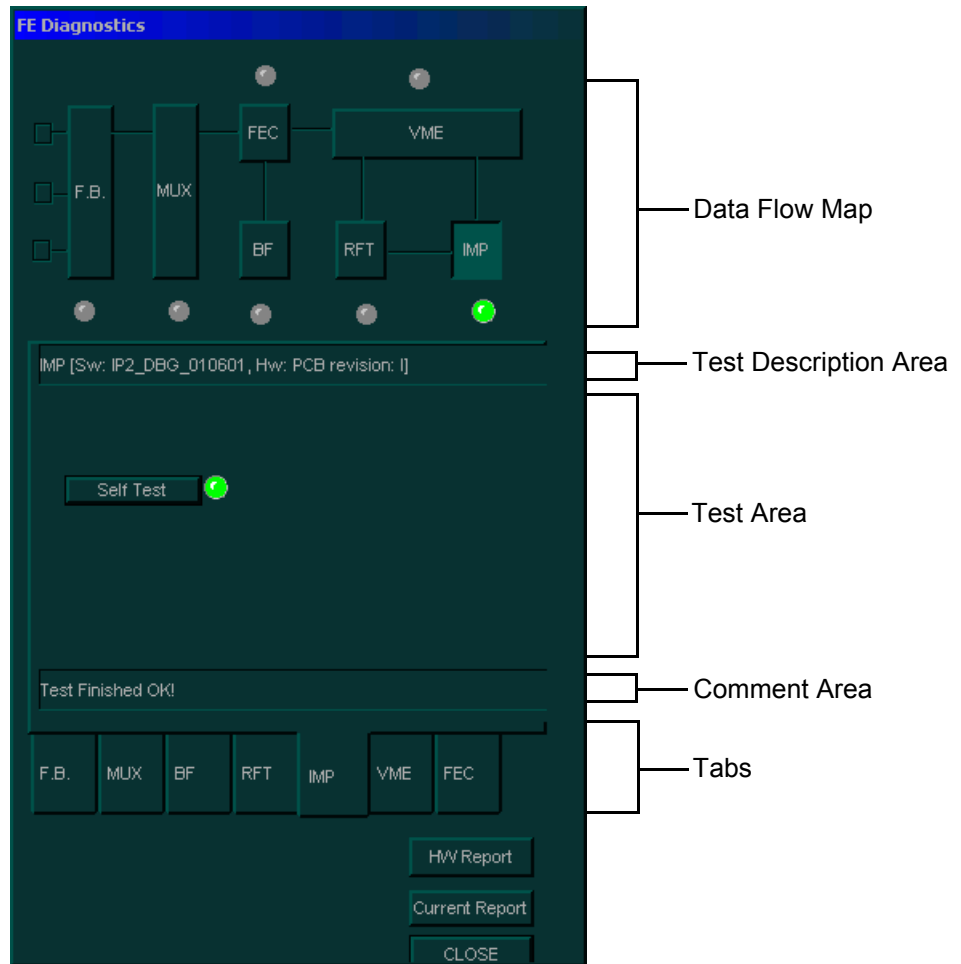

Figure 7-7 IMP Tab - FE Diagnostics Dialog Box

- 3) In the **IMP** tab, verify that the **Comment** area indicates that the system is ready to perform the test.
- 4) Trackball to the **Self Test** button and press **Select** to check the performance of the IMP board. The **Self Test** LED changes color as follows:
 - **Yellow:** The test is in progress.
 - **Green:** The test has been completed and no problems were identified.
 - **Red:** Problems were identified during the performance of the test.
- 5) Review the test results in the **Comment** area and proceed as follows:
 - If no problems were identified, proceed to the VME test, as described in the [VME Bus \(VME\) Diagnostic Tests \(for RFT Configuration\)](#) section, on page 7-15.
 - If no problems were identified but the problem persists, contact your local GE Medical Systems field engineer for assistance.
 - If errors were identified but the results were marginal, perform calibration, as described in the [Calibration](#) section, on page 6-14, and then repeat the IMP test.
 - If errors were identified and the results were not marginal, verify that all image port and PCI bridge cables are connected and functioning properly, as described in [Chapter 5 - Components and Function \(Theory\)](#). If the problem persists, contact your local GE Medical Systems field engineer for assistance.

7-3-4 VME Bus (VME) Diagnostic Tests (for RFT Configuration)

The VME Bus diagnostic test checks the communication on the VME Bus between the IP card, the FEC and the RFT.

Note: Before performing the VME Bus test, perform the IMP test, as described in the *Image Port (IMP) Diagnostic Tests (for RFT Configuration)* section, on page 7-13. If the VME Bus test is performed without first performing this test, and errors are identified, you must perform the IMP test to ensure that the VME board is the source of the error.

- 1) Access the *FE Diagnostics* dialog box, as described in the *Accessing the Front End Diagnostic Options* section, on page 7-6.
- 2) In the *FE Diagnostics* dialog box, trackball to the **VME** tab and press **Select**,

OR

Trackball to the **VME** button in the **Data Flow Map** and press **Select**.

The **VME** tab is displayed, as shown below:

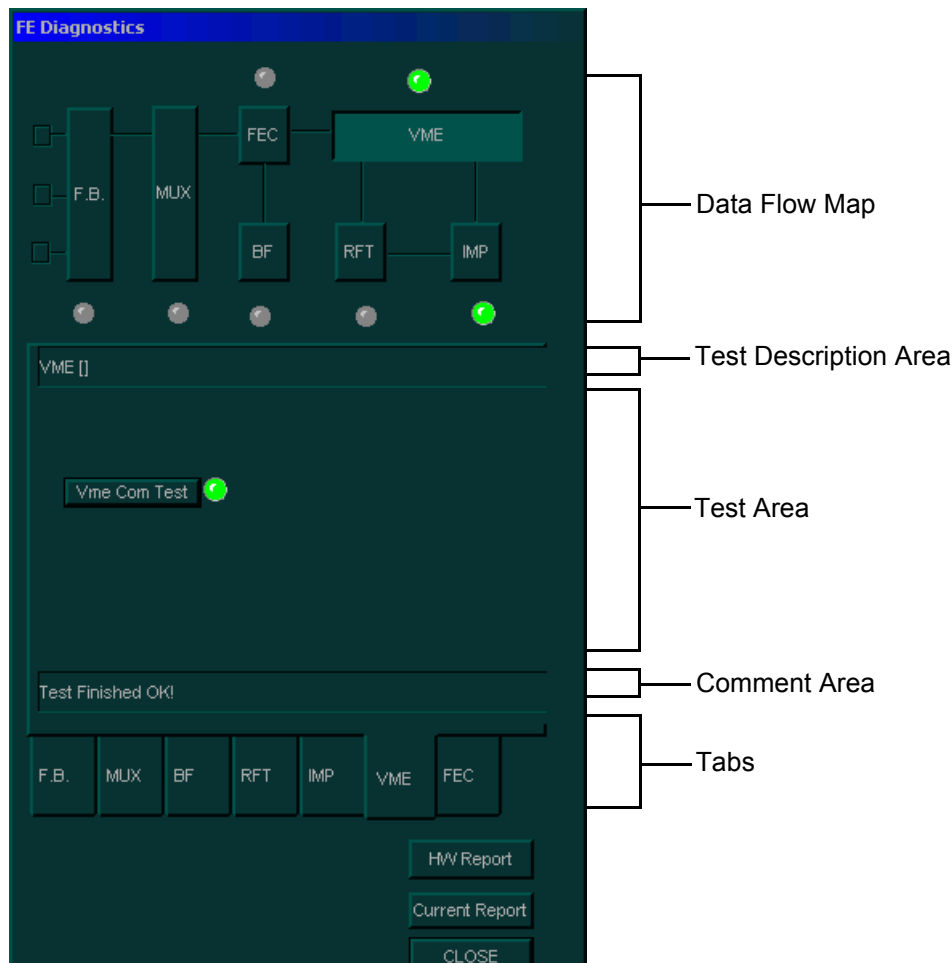

Figure 7-8 VME Tab - FE Diagnostics Dialog Box

- 3) In the **VME** tab, verify that the **Comment** area indicates that the system is ready to perform the test.
- 4) Trackball to the **Vme Com Test** button and press **Select**. The **Vme Com Test** LED changes color as follows:
 - **Yellow:** The test is in progress.
 - **Green:** The test has been completed and no problems were identified.
 - **Red:** Problems were identified during the performance of the test.
- 5) Review the test results in the **Comment** area and proceed as follows:
 - If no problems were identified, proceed to the RFT test, as described in the [RFT Diagnostic Tests \(for RFT Configuration\)](#) section, on page 7-17.
 - If no problems were identified but the problem persists, contact your local GE Medical Systems field engineer for assistance.
 - If errors were identified but the results were marginal, perform calibration, as described in [Calibration](#) on page 6 - 14, and then repeat the VME test.
 - If errors were identified and the results were not marginal, verify that all image port and PCI bridge cables are connected and functioning properly, as described in [Chapter 5 - Components and Function \(Theory\)](#). If the problem persists, contact your local GE Medical Systems field engineer for assistance.

7-3-5 RFT Diagnostic Tests (for RFT Configuration)

The RFT diagnostic tests include the tests listed below:

- **Board Test:** General RFT board test which activates the remaining tests sequentially. Each of these tests can also be performed independently.
- **Self Test 1:** Short generic board test, generated in a local DSP.
- **Self Test 2:** High level board test, generated in a local DSP. Self Test 2 lasts six minutes.

Note: Before performing the RFT test, perform the IMP and VME Bus tests, as described in the *Image Port (IMP) Diagnostic Tests (for RFT Configuration)* section, on page 7-13 and in the *VME Bus (VME) Diagnostic Tests (for RFT Configuration)* section, on page 7-15. If the RFT test is performed without first performing these tests, and errors are identified, you must perform the VME Bus test, and then the IMP test, to ensure that the RFT board is the source of the error.

1) Access the *FE Diagnostics* dialog box, as described in the *Accessing the Front End Diagnostic Options* section, on page 7-6.

2) In the *FE Diagnostics* dialog box, trackball to the **RFT** tab and press **Select**,
OR

Trackball to the **RFT** button in the **Data Flow Map** and press **Select**.

The **RFT** tab is displayed, as shown below:

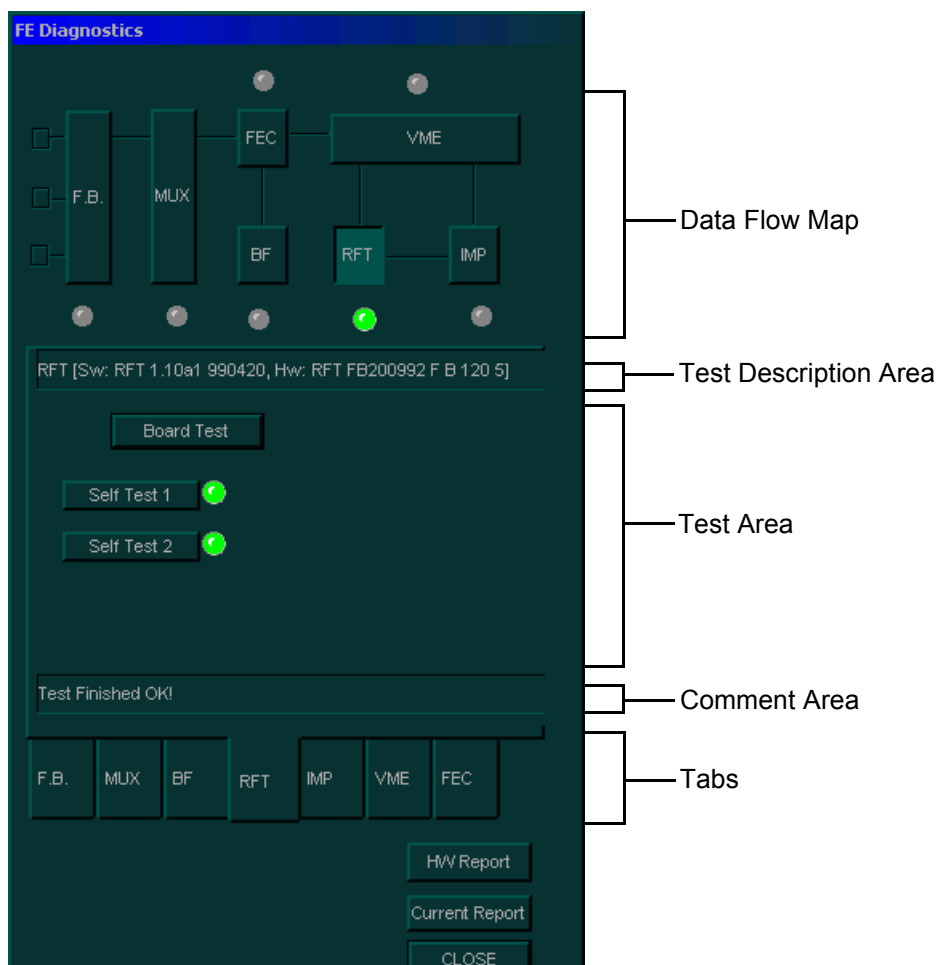

Figure 7-9 RFT Tab - FE Diagnostics Dialog Box

- 3) In the **RFT** tab, verify that the **Comment** area indicates that the system is ready to perform the test.
- 4) Trackball to one of the following buttons and press **Select**:
 - Select the **Board Test** button to perform **Self Test 1** and **Self Test 2** sequentially.
 - Select the **Self Test 1** button to perform **Self Test 1** independently.
 - Select the **Self Test 2** button to perform **Self Test 2** independently.The relevant LED changes color as follows:
 - **Yellow:** The test is in progress.
 - **Green:** The test has been completed and no problems were identified.
 - **Red:** Problems were identified during the performance of the test.
- 5) Review the test results in the **Comment** area and proceed as follows:
 - If no problems were identified, proceed to the FEC test, as described in the [Front End Controller \(FEC\) Diagnostic Tests \(for RFT Configuration\)](#) section, on page 7-19.
 - If no problems were identified but the problem persists, contact your local GE Medical Systems field engineer for assistance.
 - If errors were identified but the results were marginal, perform calibration, as described in the [Calibration](#) section, on page 6-14, and then repeat the RFT test.
 - If errors were identified and the results were not marginal, verify that all image port and PCI bridge cables are connected and functioning properly, as described in [Chapter 5 - Components and Function \(Theory\)](#). If the problem persists, contact your local GE Medical Systems field engineer for assistance.

7-3-6 Front End Controller (FEC) Diagnostic Tests (for RFT Configuration)

The FEC diagnostic tests include the following:

- **Board Test:** General board test which activates the remaining tests sequentially. Each of these tests can also be performed individually.
- **Self Test:** An FEC self test generated by the DSP on the FEC board.
- **BF Cache Test:** Checks the access to the BF cache memory that stores the data for the focuser.
- **TEE Temp Test:** Checks the TEE probe temperature sensor.
- **Thr Temp Test:** Diagnoses the temperature threshold for TEE probes.
- **Pencil ID Test:** Checks the pencil ID circuit in the FEC.

Note: Before performing any of the FEC tests, perform the IMP, VME Bus and RFT tests, as described beginning on page 7-13. If an FEC test is performed without first performing these tests, and errors are identified, you must perform the RFT test, and then the VME Bus test and the IMP test, to ensure that the FEC board is the source of the error.

1) Access the *FE Diagnostics* dialog box - see [Accessing the Front End Diagnostic Options](#) on page 7 - 6.

2) In the *FE Diagnostics* dialog box, trackball to the **FEC** tab and press **Select**,
OR

Trackball to the **FEC** button in the **Data Flow Map** and press **Select**.

The **FEC** tab is displayed, as shown below:

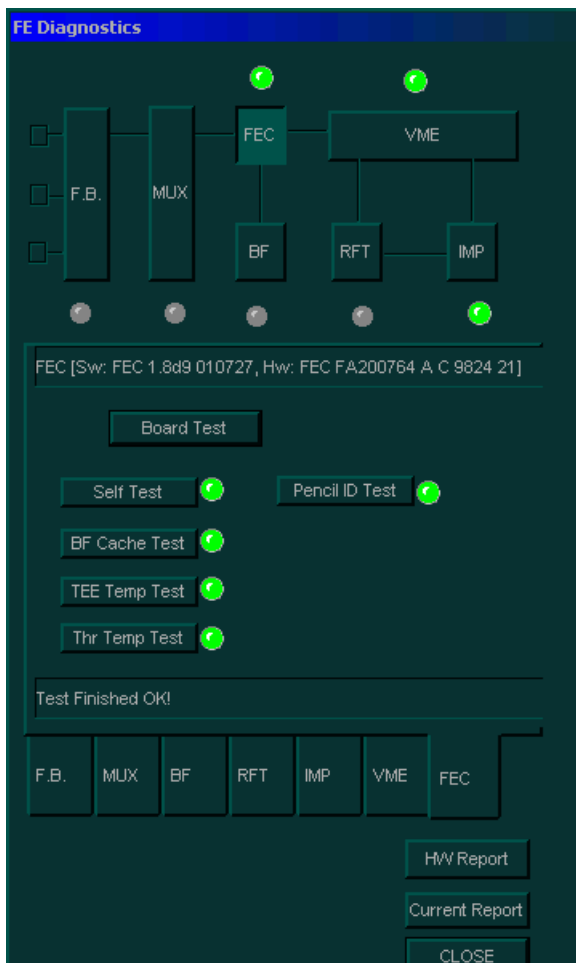

Figure 7-10 FEC Tab - FE Diagnostics Dialog Box

- 3) In the **FEC** tab, verify that the **Comment** area indicates that the system is ready to perform the test.
- 4) Trackball to one of the following buttons and press **Select**:
 - Select the **Board Test** button to perform the **Self Test**, **BF Cache Test**, **TEE Temp Test**, **Thr Temp Test** and **Pencil ID Test** sequentially.
 - Select the **Self Test** button to perform the Self Test independently.
 - Select the **BF Cache Test** button to perform the BF Cache Test independently.
 - Select the **TEE Temp Test** button to perform the TEE Temp Test independently.
 - Select the **Thr Temp Test** button to perform the Thr Temp Test independently.
 - Select the **Pencil ID Test** button to perform the Pencil ID Test independently.

The relevant LED changes color as follows:

- **Yellow:** The test is in progress.
 - **Green:** The test has been completed and no problems were identified.
 - **Red:** Problems were identified during the performance of the test.
- 5) Review the test results in the **Comment** area and proceed as follows:
 - If no problems were identified, proceed to the BF test, as described in the [Beamformer \(BF\) Diagnostic Tests](#) section, on page 7-21.
 - If no problems were identified but the problem persists, contact your local GE Medical Systems field engineer for assistance.
 - If errors were identified but the results were marginal, perform calibration, as described in the [Calibration](#) section, on page 6-14, and then repeat the test.
 - If errors were identified and the results were not marginal, verify that all image port and PCI bridge cables are connected and functioning properly, as described in [Chapter 5 - Components and Function \(Theory\)](#). If the problem persists, contact your local GE Medical Systems field engineer for assistance.

7-3-7 Beamformer (BF) Diagnostic Tests

The BF diagnostic tests enable you to check the ADC output and perform a digital beamformer test.

Note: Before performing the BF tests, perform the IMP, VME Bus, RFT and FEC tests, as described beginning on page 7-13. If the BF test is performed without first performing these tests, and errors are identified, you must perform the FEC tests, then the RFT test, the VME Bus test, and the IMP test, to ensure that the BF board is the source of the error.

NOTE: When replacing the BF, perform calibration as described in the [Calibration](#) section, on page 6-14.

NOTE: **IMPORTANT** - Do not perform BF Calibration after operating in CW or PW scanning modes since validation will fail. Perform the BF Calibration procedure only after 2D scanning mode.

- 1) Access the *FE Diagnostics* dialog box, as described in the [Accessing the Front End Diagnostic Options](#) section, on page 7-6.
- 2) In the *FE Diagnostics* dialog box, trackball to the **BF** tab and press **Select**,

OR

Trackball to the **BF** button in the **Data Flow Map** and press **Select**.

The **BF** tab is displayed, as shown in [Figure 7-11](#) (or [Figure 7-12](#)) below:

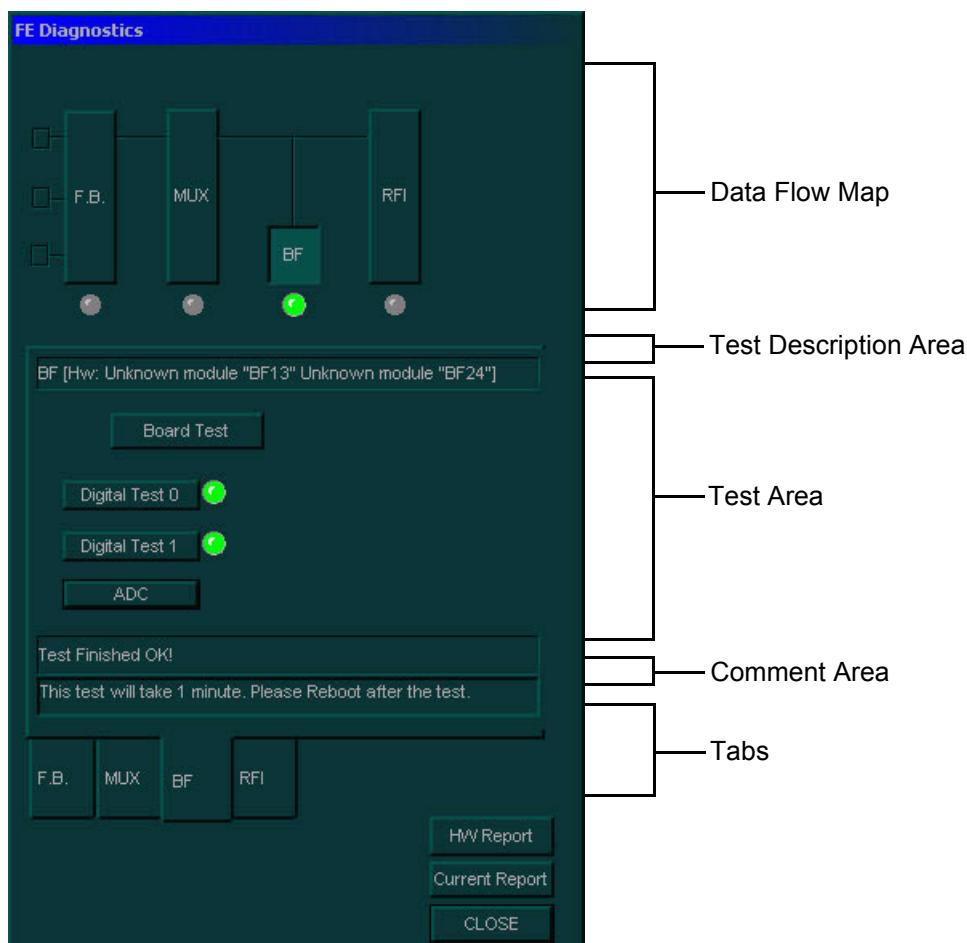

Figure 7-11 BF Tab - FE Diagnostics Dialog Box (RFI Configuration)

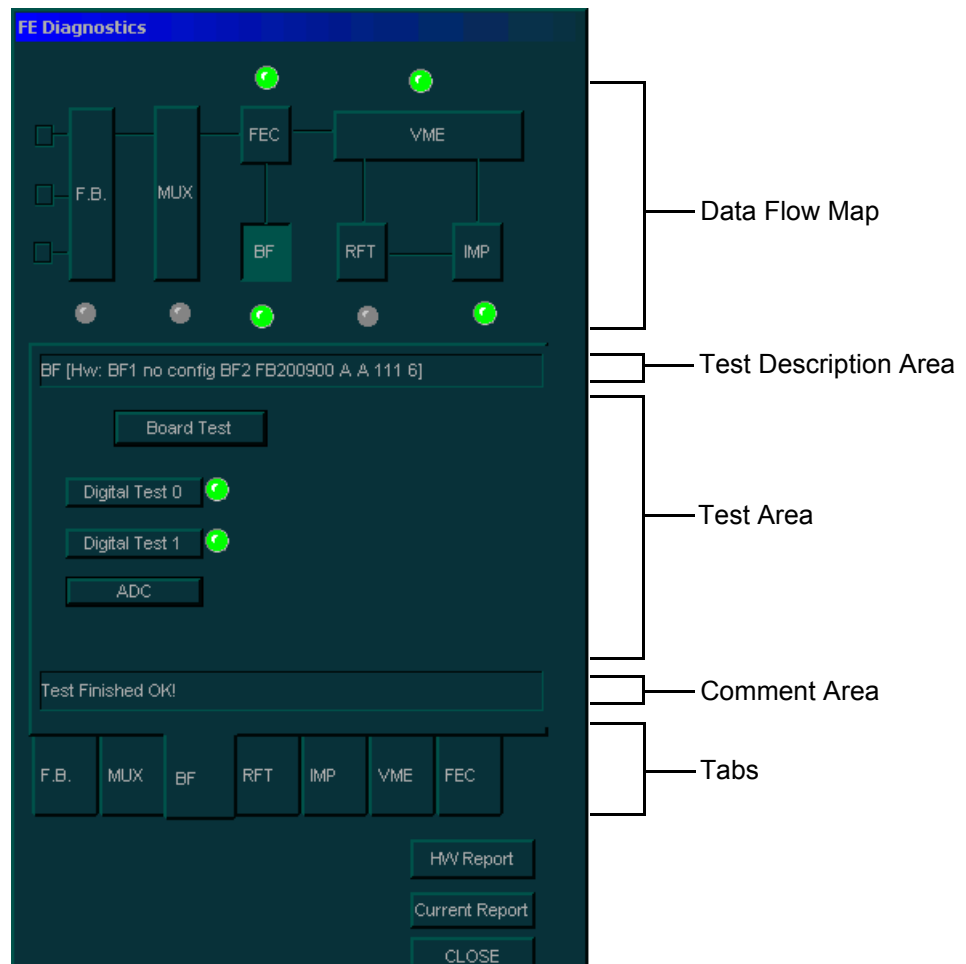

Figure 7-12 BF Tab - FE Diagnostics Dialog Box (RFT Configuration)

- 3) Proceed as follows: Trackball to one of the following buttons and press **Select**:
 - Trackball to the **Board Test** button and press **Select**
OR
 - Perform the Digital Test 0 and Digital Test 1 independently, as follows. Trackball to the **Digital Test 0** button and press **Select**. When complete, trackball to the **Digital Test 1** button and press **Select**.
- 4) In the **BF** tab, verify that the **Comment** area indicates that the system is ready to perform the test.
- 5) Trackball to the **ADC** button and press **Select**. The beamformer digital test and ADC bit tests are activated sequentially. The test results are displayed, per vector, in the *Ultrasound Scope* window, as shown in [Figure 7-13](#) below.

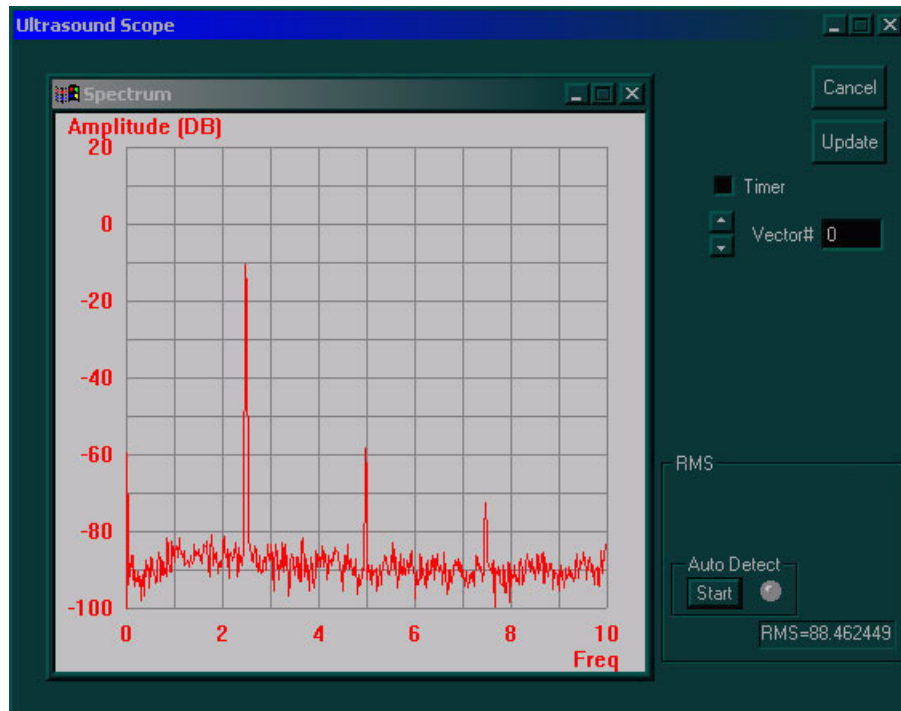

Figure 7-13 Ultrasound Scope Window

- 6) Under *Auto Detect*, click the **Start** button. Checking of the test results commences and the light adjacent to the button flashes green and continues to flash while *Auto Detect* is in progress. If a fault is detected, the flashing light changes to red and an error log is displayed listing the channel/s on which the test failed.

Alternatively, review the information manually, using the scroll arrows on the right of the *Ultrasound Scope* window to select a vector between 0 and 63. The selected vector is displayed in the **Vector #** field and its test results are displayed in the **Spectrum** area.

Check the test results for each vector, as follows:

- Verify that the RMS level displayed in the **RMS** field is above 84 (in absolute value).
- Verify that the amplitude at frequency 2.5 is within a range of -5 to -20.
- Verify that the amplitude at frequency 5 is below -40.
- Verify that the amplitude at frequency 7.5 is below -60.

Note: If the RMS level is above or below the specified level, reboot the system, perform calibration and repeat the test.

- 7) Proceed as follows:
 - If no problems were identified, proceed to the FB tests, as described in the [Front Board Assembly \(FB\) Diagnostic Tests](#) section, on page 7-25.
 - If no problems were identified but the problem persists, contact your local GE Medical Systems field engineer for assistance.
 - If errors were identified but the results were marginal, perform calibration, as described in the [Calibration](#) section, on page 6-14, and then repeat the test.
 - If errors were identified and the results were not marginal, verify that all image port and PCI bridge cables are connected and functioning properly, as described in [Chapter 5 - Components and Function \(Theory\)](#). If the problem persists, contact your local GE Medical Systems field engineer for assistance.
- 8) When finished, trackball to the **Cancel** button and press **Select**. The *FE Diagnostics* dialog box is re-displayed.

7-3-8 Front Board Assembly (FB) Diagnostic Tests

The FB diagnostics tests check the FB circuits and boards. To avoid frequent rebooting of the system, these tests must be performed in the sequence described below. When performing FB tests out of sequence, follow the instructions displayed in the **Comment** area of the *FE Diagnostics* dialog box, and reboot as required. Refer to [Chapter 5 - Components and Function \(Theory\)](#) for additional details about the FB circuits and boards.

Note: Before performing the FB tests, make sure that the RFI (or IMP, VME Bus, RFT, FEC) and BF diagnostic tests have been performed, as described beginning on page 7-13.

If the FB tests are performed without first performing these tests, and errors are identified, you must perform the following tests (*in the order listed*) to ensure that the FB is in fact the source of the error:

For Systems with RFI Configuration:

- MUX Diagnostic Test
- Beamformer (BF) Diagnostic Test
- Radio Frequency Interface (RFI) Diagnostic Test

For Systems with RFT Configuration:

- MUX Diagnostic Test
- Beamformer (BF) Diagnostic Test
- Front End Controller (FEC) Diagnostic Test
- RFT Diagnostic Test
- VME Bus Diagnostic Test
- Image Port (IMP) Diagnostic Test

7-3-8-1 Accessing the Front Board Assembly Options

- 1) Access the *FE Diagnostics* dialog box, as described in the [Accessing the Front End Diagnostic Options](#) section, on page 7-6.
- 2) In the *FE Diagnostics* dialog box, trackball to the **F.B.** tab and press **Select**,

OR

Trackball to the **F.B.** button in the **Data Flow Maps** and press **Select**. The **F.B.** tab is displayed, as shown in [Figure 7-14](#) on page 7-26 (or [Figure 7-15](#) on page 7-27).

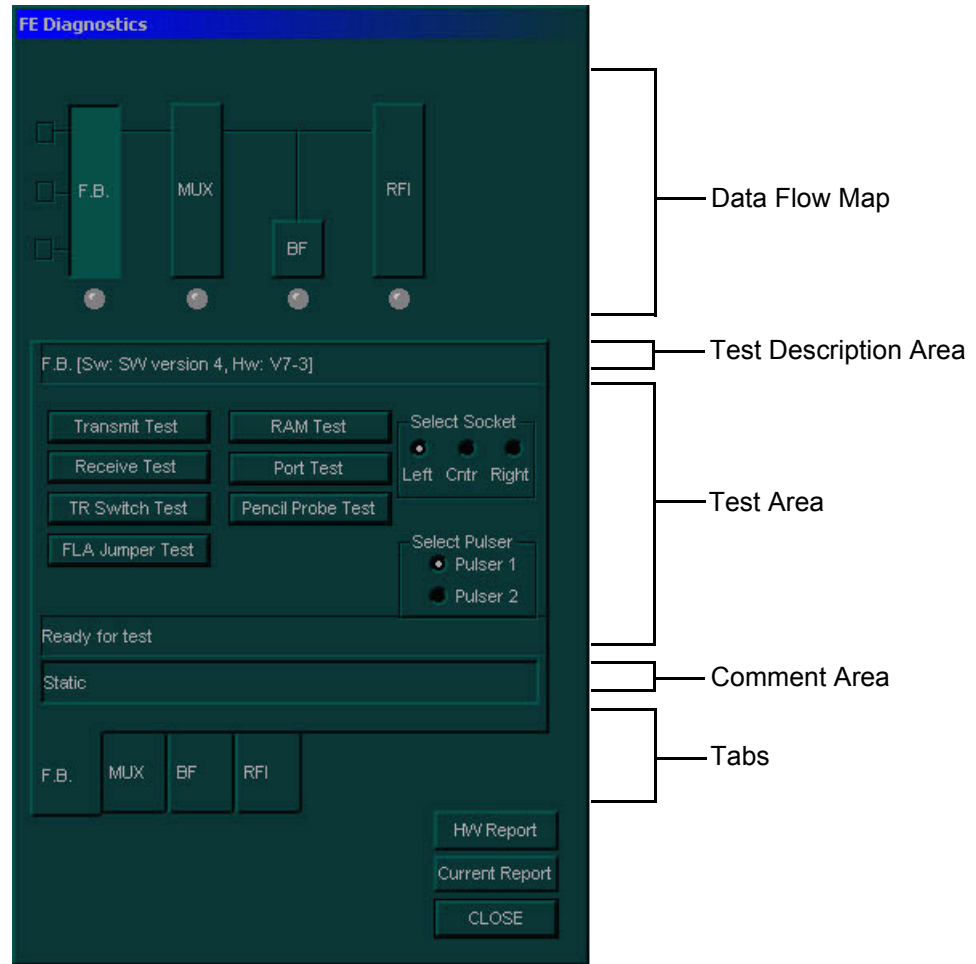

Figure 7-14 F.B. Tab - FE Diagnostics Dialog Box (RFI Configuration)

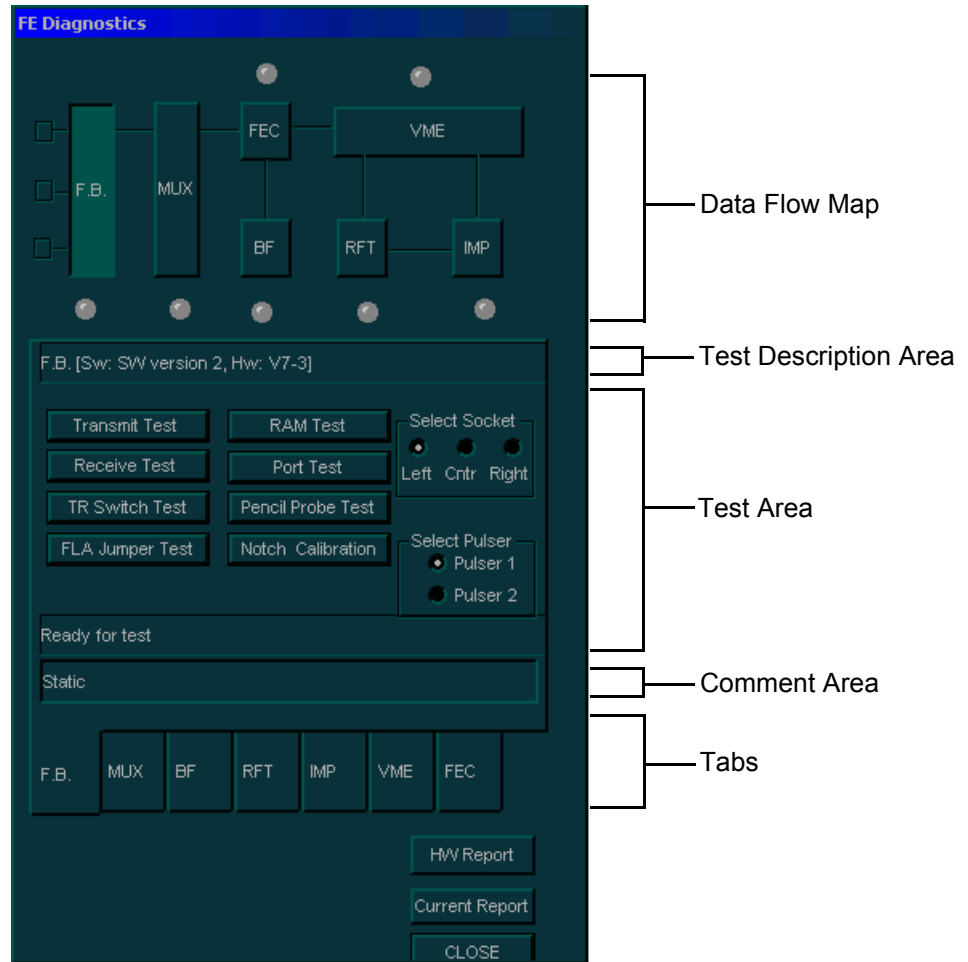

Figure 7-15 F.B. Tab - FE Diagnostics Dialog Box (RFT Configuration)

- 3) Trackball to the following buttons (in the order shown) and press **Select**:
 - a.) **Transmit Test**: Checks the FE pulser via the probe elements, as described in the [Transmit Test](#) section, on page 7-28.
 - b.) **Receive Test**: Tests each amplifier output against the predefined output level, as described in the [Receive Test](#) section, on page 7-34.
 - c.) **TR Switch Test**: Checks the transmit switches, as described in the [TR Switch Test](#) section, on page 7-38.
 - d.) **FLA Jumper Test**: Checks the jumpers that connect the side elements to the center elements, as described in the [FLA Jumper Switch](#) section, on page 7-30.
 - e.) **Pencil Probe Test**: Checks the transmitting channels associated relays to the pencil probe port, as described in the [Pencil Probe Test](#) section, on page 7-40.
 - f.) **Port Test**: Checks general logic control and ports logic, as described in [Port Test](#) section, on page 7-44.
 - g.) **RAM Test**: Checks the RAM that stores the delays for the transmitted ultrasound signals to the form focal beam, as described in the [RAM Test](#) section, on page 7-45.

7-3-8-2 Transmit Test

If a solid dark line is observed during scanning, it may indicate a bad transmitting channel. The transmit test checks the FE pulsers via the probe elements, enabling you to check the transmitting channels. The transmit test is not sensitive to the receiving channels.

Note: To avoid irrelevant failure results, it is imperative that the probe used to perform the transmit test is in good condition.

- 1) Connect either a 7S or 3S probe and lock it in place.
- 2) Access the **F.B.** tab of the *FE Diagnostics* dialog box, as described in the [Accessing the Front Board Assembly Options](#) section, on page 7-25.
- 3) In the **Select Socket** area of the **F.B.** tab, trackball to the socket to which the 7S or 3S probe is connected:
 - Trackball to **Left, Right** or **Center** and press **Select**.
- 4) Trackball to **Pulsar 1** (High Voltage Power Supply [HVPS] +/-80V) or **Pulsar 2** (Low Voltage Power Supply [LVPS] +/-40V) and press **Select**.
- 5) Trackball to the **Transmit Test** button and press **Select**. The transmit test is performed and the test results are displayed in the *Report* dialog box, as shown below:

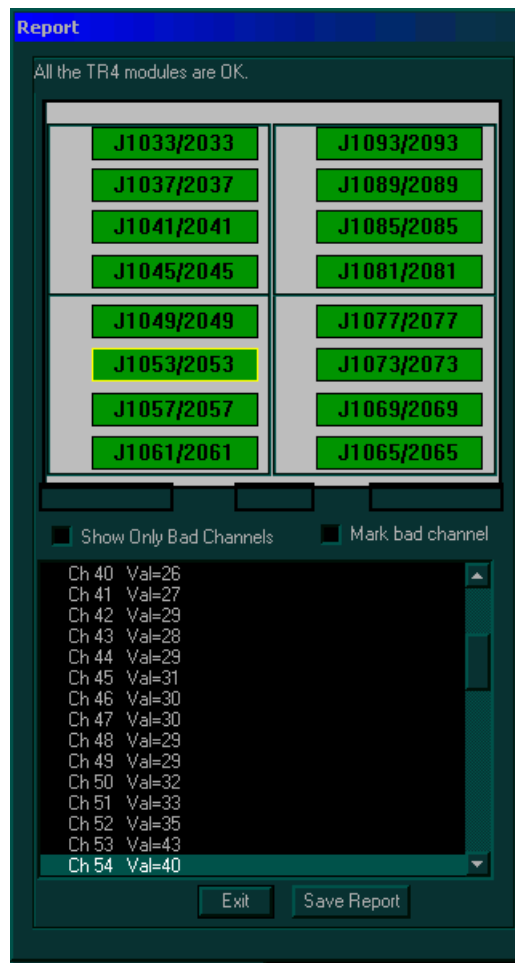

Figure 7-16 Report Dialog Box - Transmit Test

The *Report* dialog box contains the following information:

- **Test Result Message:** Displays the test result.
 - **TR4 Modules:** Displays a graphic representation of the front board (four groups of TR4 sockets). Each group consists of four TR4 sockets, each socket containing four vectors (channels), as follows:
 - Each vector is represented by a button (highlighted in green) that displays the number of the socket to which the TR4 is connected.
 - Each button is highlighted yellow when selected.
 - Each button is highlighted red if errors were detected for one or more channels.
 - **Checkboxes:** Enable you to manipulate bad channels:
 - **Show Only Bad Channels:** Select this checkbox to display only bad channels in the **Display** area.
 - **Mark bad channel:** Select this checkbox to manually mark the currently selected channel as bad.
 - **Vector Line:** Displays a graphic representation of the selected vector. This line is green if the vector is good, and yellow if it is bad.
- 6) Check the test result message in the *Report* dialog box:
- If one or more channels were identified as bad, trackball to the **Save Report** button and press **Select**, then contact a GE Medical Systems service representative.
 - If no channels were identified as bad, mark the channels suspected as being bad as follows:
 - Trackball to each of the channels in the **Display** area and press select.
 - Trackball to the **Mark bad channel** checkbox and press **Select**.
 - Trackball to **Save Report** and press **Select**, and contact a GE Medical Systems service representative.
 - If no errors were identified, proceed with the next test.
 - If no errors were identified but the problem persists, contact your local GE Medical Systems field engineer for assistance.
 - If errors were identified but the results were marginal, perform calibration, as described in the [Calibration](#) section, on page 6-14, and then repeat the test.
 - If errors were identified and the results were not marginal, verify that all image port and PCI bridge cables are connected and functioning properly, as described in [Chapter 5 - Components and Function \(Theory\)](#). If the problem persists, contact your local GE Medical Systems field engineer for assistance.
- 7) Trackball to the **Exit** button and press **Select**. If required, repeat this test with a different pulser.

7-3-8-3 FLA Jumper Switch

All the elements are connected through the transmit and receive jumpers. This test checks the jumpers that connect the side elements to the center elements. During this test, every probe element transmits and receives signals. The test has two phases, namely *Open jumper test* and *Closed jumper test*.

- 1) Connect the 10L (739L) probe and lock it in place.

Note: To avoid irrelevant failure results, it is imperative that *only this probe is used and that it be in good condition*.

- 2) Access the **F.B.** tab of the *FE Diagnostics* dialog box, as described in the [Accessing the Front Board Assembly Options](#) section, on page 7-25.
- 3) In the **Select Socket** area of the **F.B.** tab, trackball to the socket to which the 10L probe is connected:
 - Trackball to **Left, Right** or **Center** and press **Select**.
- 4) Trackball to **Pulsar 1** (High Voltage Power Supply [HVPS] +/-80V) or **Pulsar 2** (Low Voltage Power Supply [LVPS] +/-40V) and press **Select**.
- 5) Trackball to the **FLA Jumper Test** button and press **Select**. The open FLA jumper test is performed, and the test results are displayed in the *Report* dialog box, as shown below:

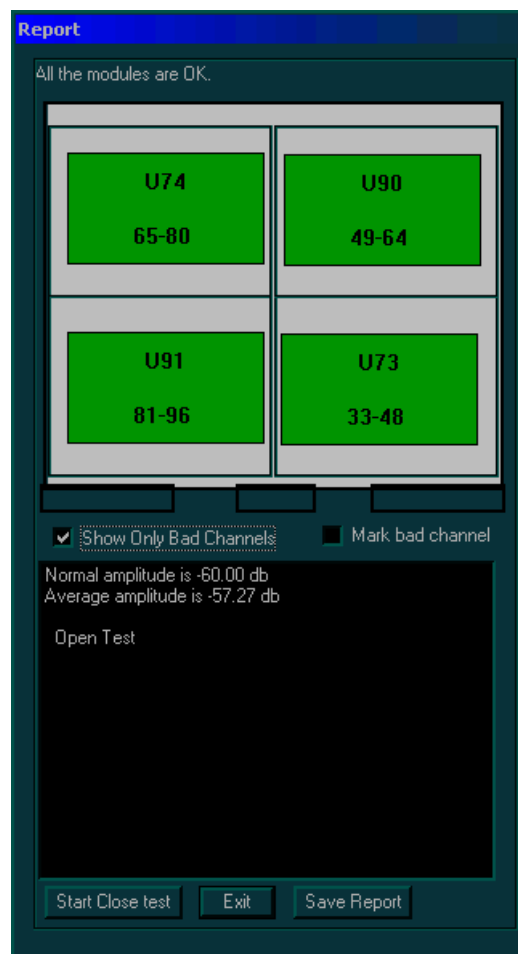

Figure 7-17 Report Dialog Box - Open FLA Jumper Test

The *Report* dialog box contains the following information:

- **Test Result Message:** Displays the test result.
 - **FB Elements:** Displays a graphic representation of the front board elements, as follows:
 - Each element is represented by a button (highlighted in green) that displays the element, and the channel number that is associated with that element.
 - Each button is highlighted yellow when selected.
 - Each button is highlighted red if errors were detected for one or more elements.
 - **Checkboxes:** Enable you to manipulate bad channels:
 - **Show Only Bad Channels:** Select this checkbox to display only bad channels in the **Display** area.
 - **Mark bad channel:** Select this checkbox to manually mark the currently selected channel as bad.
- 6) Check the test result message and proceed as follows:
- If one or more channels were identified as bad, trackball to the **Save Report** button and press **Select**, then contact a GE Medical Systems Service Representative.
 - If no channels were identified as bad, mark the channels suspected as being bad as follows:
 - Trackball to each of the channels in the **Display** area and press select.
 - Trackball to the **Mark bad channel** checkbox and press **Select**.
 - Trackball to **Save Report** and press **Select**, and contact a GE Medical Systems service representative.
- 7) Trackball to the **Start Close test** button and press **Select**. The closed FLA jumper test is performed. and the test results are displayed in the *Report* dialog box, as shown in [Figure 7-22](#) on page 7-40.



Figure 7-18 Report Dialog Box - FLA Jumper Test (Closed)

The *Report* dialog box contains the following information:

- **Test Result Message:** Displays the test result.
- **FB Elements:** Displays a graphic representation of the front board elements, as follows:
 - Each element is represented by a button (highlighted in green) that displays the element, and the channel number that is associated with that element.
 - Each button is highlighted yellow when selected.
 - Each button is highlighted red if errors were detected for one or more elements.
- **Checkboxes:** Enable you to manipulate bad channels:
 - **Show Only Bad Channels:** Select this checkbox to display only bad channels in the **Display** area.
 - **Mark bad channel:** Select this checkbox to manually mark the currently selected channel as bad.

- 8) Check the test result message and proceed as follows:
- If one or more channels were identified as bad, trackball to the **Save Report** button and press **Select**, then contact a GE Medical Systems Service Representative.
 - If no channels were identified as bad, mark the channels suspected as being bad as follows:
 - Trackball to each of the channels in the **Display** area and press select.
 - Trackball to the **Mark bad channel** checkbox and press **Select**.
 - Trackball to **Save Report** and press **Select**, and contact a GE Medical Systems service representative.
 - If no errors were identified, proceed with the next test.
 - If no errors were identified but the problem persists, contact your local GE Medical Systems field engineer for assistance.
 - If errors were identified but the results were marginal, perform calibration, as described in the [Calibration](#) section, on page 6-14, and then repeat the test.
 - If errors were identified and the results were not marginal, verify that all image port and PCI bridge cables are connected and functioning properly, as described in [Chapter 5 - Components and Function \(Theory\)](#). If the problem persists, contact your local GE Medical Systems field engineer for assistance.
- 9) Trackball to the **Exit** button and press **Select**. If required, repeat this test with a different pulser.

7-3-8-4 Receive Test

The Receive Test checks each amplifier output against the predefined output level. This system test is performed in Phased Array Probe Simulation mode. The FEC board injects analog signals to the Tx amplifiers inputs after the Tx switch. The test lasts approximately 4 minutes.

Note: System re-boot is required if the tests are not being performed in the sequence described in the [Performing Front End \(FE\) Diagnostics](#) section, on page 7-5.

- 1) Disconnect all the probes.
- 2) Access the **F.B.** tab of the *FE Diagnostics* dialog box, as described in the [Accessing the Front Board Assembly Options](#) section, on page 7-25.
- 3) Trackball to **Pulser 1** (High Voltage Power Supply [HVPS] +/-80V) or **Pulser 2** (Low Voltage Power Supply [LVPS] +/-40V) and press **Select**.
- 4) Trackball to the **Receive Test** button and press **Select**. The receive test is performed, and the test results are displayed in the *Report* dialog box, as shown below:



Figure 7-19 Report Dialog Box - Receive Test

The *Report* dialog box contains the following information:

- **Test Result Message:** Displays the test result.
 - **TR4 Modules:** Displays a graphic representation of the front board (four groups of TR4 sockets). Each group consists of four TR4 sockets, each socket containing four vectors (channels), as follows:
 - Each vector is represented by a button (highlighted in green) that displays the number of the socket to which the TR4 is connected.
 - Each button is highlighted yellow when selected.
 - Each button is highlighted red if errors were detected for one or more channels.
 - **Checkboxes:** Enable you to manipulate bad channels:
 - **Show Only Bad Channels:** Select this checkbox to display only bad channels in the **Display** area.
 - **Mark bad channel:** Select this checkbox to manually mark the currently selected channel as bad.
- 5) Check the test result message and proceed as follows:
- If one or more channels were identified as bad, trackball to the **Save Report** button and press **Select**, then contact a GE Medical Systems Service Representative.
 - If no channels were identified as bad, mark the channels suspected as being bad as follows:
 - Trackball to each of the channels in the **Display** area and press **Select**.
 - Trackball to the **Mark bad channel** checkbox and press **Select**.
 - Trackball to **Save Report** and press **Select**, and contact a GE Medical Systems service representative.
- 6) Trackball to the **Low Freq Test** button and press **Select**. The receive test is performed in low frequency mode, and the test results are displayed in the *Report* dialog box, as shown in [Figure 7-20](#) on page 7-36:



Figure 7-20 Report Dialog Box - Receive Test Low Frequency

The *Report* dialog box contains the following information:

- **Test Result Message:** Displays the test result.
- **TR4 Modules:** Displays a graphic representation of the front board (four groups of TR4 sockets). Each group consists of four TR4 sockets, each socket containing four vectors (channels), as follows:
 - Each vector is represented by a button (highlighted in green) that displays the number of the socket to which the TR4 is connected.
 - Each button is highlighted yellow when selected.
 - Each button is highlighted red if errors were detected for one or more channels.
- **Checkboxes:** Enable you to manipulate bad channels:
 - **Show Only Bad Channels:** Select this checkbox to display only bad channels in the **Display** area.
 - **Mark bad channel:** Select this checkbox to manually mark the currently selected channel as bad.

- 7) Check the test result message and proceed as follows:
- If one or more channels were identified as bad, trackball to the **Save Report** button and press **Select**, then contact a GE Medical Systems Service Representative.
 - If no channels were identified as bad, mark the channels suspected as being bad as follows:
 - Trackball to each of the channels in the **Display** area and press select.
 - Trackball to the **Mark bad channel** checkbox and press **Select**.
 - Trackball to **Save Report** and press **Select**, and contact a GE Medical Systems service representative.
 - If no errors were identified, proceed with the next test.
 - If no errors were identified but the problem persists, contact your local GE Medical Systems field engineer for assistance.
 - If errors were identified but the results were marginal, perform calibration, as described in the [Calibration](#) section, on page 6-14, and then repeat the test.
 - If errors were identified and the results were not marginal, verify that all image port and PCI bridge cables are connected and functioning properly, as described in [Chapter 5 - Components and Function \(Theory\)](#). If the problem persists, contact your local GE Medical Systems field engineer for assistance.
- 8) Trackball to the **Exit** button and press **Select**. If required, repeat this test with a different pulser.

7-3-8-5 TR Switch Test

If a solid line is observed during scanning, it may indicate a bad TR switch. This test checks the transmit switches.

- 1) Connect a 3S probe and lock it in place.

Note: To avoid irrelevant failure results, it is imperative that the probe be in good condition.

- 2) Access the **F.B.** tab of the *FE Diagnostics* dialog box, as described in the [Accessing the Front Board Assembly Options](#) section, on page 7-25.
- 3) In the **Select Socket** area of the **F.B.** tab, trackball to the socket to which the 3S probe is connected:
 - Trackball to **Left, Right** or **Center** and press **Select**.
- 4) Trackball to **Pulsar 1** (High Voltage Power Supply [HVPS] +/-80V) or **Pulsar 2** (Low Voltage Power Supply [LVPS] +/-40V) and press **Select**.
- 5) Trackball to the **TR Switch Test** button and press **Select**. The TR switch test is performed, and the test results are displayed in the *Report* dialog box, as shown below:

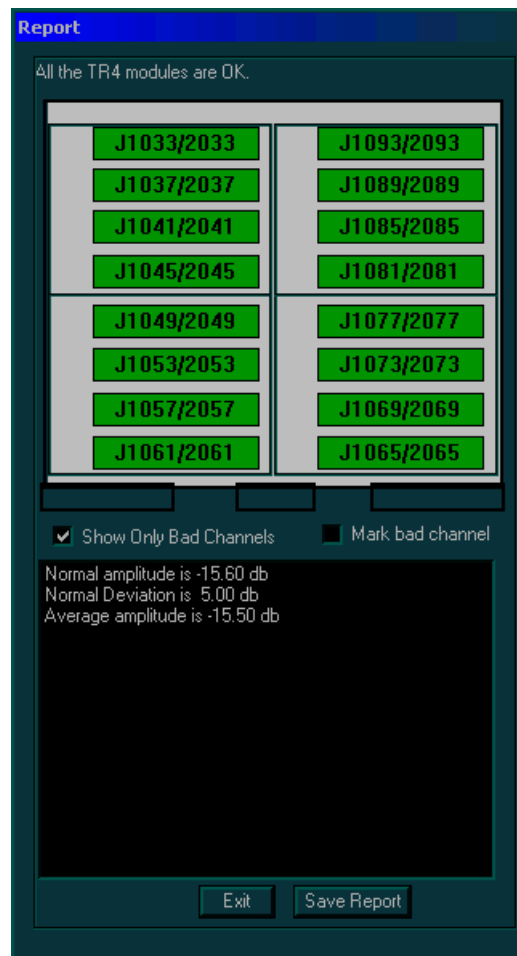

Figure 7-21 Report Dialog Box - TR Switch Test

The *Report* dialog box contains the following information:

- **Test Result Message:** Displays the test result.
 - **TR4 Modules:** Displays a graphic representation of the front board (four groups of TR4 sockets). Each group consists of four TR4 sockets, each socket containing four vectors (channels), as follows:
 - Each vector is represented by a button (highlighted in green) that displays the number of the socket to which the TR4 is connected.
 - Each button is highlighted yellow when selected.
 - Each button is highlighted red if errors were detected for one or more channels.
 - **Checkboxes:** Enable you to manipulate bad channels:
 - **Show Only Bad Channels:** Select this checkbox to display only bad channels in the **Display** area.
 - **Mark bad channel:** Select this checkbox to manually mark the currently selected channel as bad.
- 6) Check the test result message and proceed as follows:
- If one or more channels were identified as bad, trackball to the **Save Report** button and press **Select**, then contact a GE Medical Systems Service Representative.
 - If no channels were identified as bad, mark the channels suspected as being bad as follows:
 - Trackball to each of the channels in the **Display** area and press select.
 - Trackball to the **Mark bad channel** checkbox and press **Select**.
 - Trackball to **Save Report** and press **Select**, and contact a GE Medical Systems service representative.
 - If no errors were identified, proceed with the next test.
 - If no errors were identified but the problem persists, contact your local GE Medical Systems field engineer for assistance.
 - If errors were identified but the results were marginal, perform calibration, as described in the [Calibration](#) section, on page 6-14, and then repeat the test.
 - If errors were identified and the results were not marginal, verify that all image port and PCI bridge cables are connected and functioning properly, as described in [Chapter 5 - Components and Function \(Theory\)](#). If the problem persists, contact your local GE Medical Systems field engineer for assistance.
- 7) Trackball to the **Exit** button and press **Select**. If required, repeat this test with a different pulser.

7-3-8-6 Pencil Probe Test

If a solid black line is observed during scanning, it may indicate a bad transmitting channel. The pencil probe test checks the transmitting channels associated relays to the pencil probe port. This test is not for sensitive receiving channels. The test has two phases, namely the *open* pencil probe test and the *close* pencil probe test.

- 1) Connect a 2D pencil probe.
- 2) Access the **F.B.** tab of the *FE Diagnostics* dialog box, as described in the [Accessing the Front Board Assembly Options](#) section, on page 7-25.
- 3) Trackball to **Pulsar 1** (High Voltage Power Supply [HVPS] $\pm 80V$) or **Pulsar 2** (Low Voltage Power Supply [LVPS] $\pm 40V$) and press **Select**.
- 4) Trackball to the **Pencil Probe Test** button and press **Select**. The pencil probe test is performed, and the test results are displayed in the *Report* dialog box, as shown below:



Figure 7-22 Report Dialog Box - Pencil Probe Test (Open)

The *Report* dialog box includes the following:

- **Test Result Message:** Displays the test result.
 - **Pencil Probe Relays:** Displays a graphic representation of the eight front board pencil probe relays, as follows:
 - Each relay is represented by a button (highlighted in green) that displays the relay number.
 - Each button is highlighted in yellow when selected.
 - Each button is highlighted in red if errors were detected for one or more relays.
 - **Checkboxes:** Enable you to manipulate bad channels:
 - **Show Only Bad Channels:** Select this checkbox to display only the bad channels in the **Display** area.
 - **Mark bad Channel:** Select this checkbox to manually mark the currently selected channel as bad.
- 5) Check the test result message and proceed as follows:
- If one or more relays were identified as bad, trackball to **Save Report** and press **Select**, and contact a GE Medical Systems service representative.
 - If no relays were identified as bad, mark the channels suspected as being bad as follows:
 - Trackball to the channel in the Display area and press **Select**.
 - Trackball to the **Mark bad channel** checkbox and press **Select**. Repeat as required to mark additional channels.
 - Trackball to **Save Report** and press **Select**, and contact a GE Medical Systems service representative.
- 6) Trackball to the **Start Close test** and press **Select**. The pencil probe test (close) is performed and the test results are displayed in the *Report* dialog box, as shown in [Figure 7-23](#) on page 7-42.



Figure 7-23 Report Dialog Box - Pencil Probe Test (Close)

The *Report* dialog box includes the following:

- **Test Result Message:** Displays the test result.
- **Pencil Probe Relays:** Displays a graphic representation of the eight front board pencil probe relays, as follows:
 - Each relay is represented by a button (highlighted in green) that displays the relay number.
 - Each button is highlighted in yellow when selected.
 - Each button is highlighted in red if errors were detected for one or more relays.
- **Checkboxes:** Enable you to manipulate bad channels:
 - **Show Only Bad Channels:** Select this checkbox to display only the bad channels in the **Display** area.
 - **Mark bad Channel:** Select this checkbox to manually mark the currently selected vector as bad.

- 7) Check the test result message and proceed as follows:
- If one or more relays were identified as bad, trackball to **Save Report** and press **Select**, and contact a GE Medical Systems service representative.
 - If no relays were identified as bad, mark the channels suspected as being bad as follows:
 - Trackball to the channel in the Display area and press **Select**.
 - Trackball to the **Mark bad channel** checkbox and press **Select**. Repeat as required to mark additional channels.
 - Trackball to **Save Report** and press **Select**, and contact a GE Medical Systems service representative.
 - If no errors were identified, proceed with the next test.
 - If no errors were identified but the problem persists, contact your local GE Medical Systems field engineer for assistance.
 - If errors were identified but the results were marginal, perform calibration, as described in the [Calibration](#) section, on page 6-14, and then repeat the test.
 - If errors were identified and the results were not marginal, verify that all image port and PCI bridge cables are connected and functioning properly, as described in [Chapter 5 - Components and Function \(Theory\)](#). If the problem persists, contact your local GE Medical Systems field engineer for assistance.
- 8) Trackball to the **Exit** button and press **Select**. If required, repeat this test with a different pulser.

7-3-8-7 Port Test

The Port test enables you to check the general logic control and ports logic.

Note: You must reboot the system after performing the Port test.

- 1) Disconnect all probes.
- 2) Access the **F.B.** tab of the *FE Diagnostics* dialog box, as described in the [Accessing the Front Board Assembly Options](#) section, on page 7-25.
- 3) Trackball to the **Port Test** button and press **Select**. The port test is performed and the results are displayed in the **Comments** area.
- 4) Check the test results and proceed as follows:
 - If no errors were identified, proceed with the next test.
 - If no errors were identified but the problem persists, contact your local GE Medical Systems field engineer for assistance.
 - If errors were identified but the results were marginal, perform calibration, as described in the [Calibration](#) section, on page 6-14, and then repeat the test.
 - If errors were identified and the results were not marginal, verify that all image port and PCI bridge cables are connected and functioning properly, as described in [Chapter 5 - Components and Function \(Theory\)](#). If the problem persists, contact your local GE Medical Systems field engineer for assistance.
- 5) Reboot the system.

7-3-8-8 RAM Test

The RAM test enables you to check the RAM that stores the delays for the transmitted ultrasound signals to the form focal beam.

Note: You must reboot the system after performing the RAM test.

- 1) Access the **F.B.** tab of the *FE Diagnostics* dialog box, as described in the [Accessing the Front Board Assembly Options](#) section, on page 7-25.
- 2) Trackball to the **RAM Test** button and press **Select**. The RAM test is performed and the results are displayed in the **Comments** area, as shown in [Figure 7-24](#) (or [Figure 7-25](#)) below:

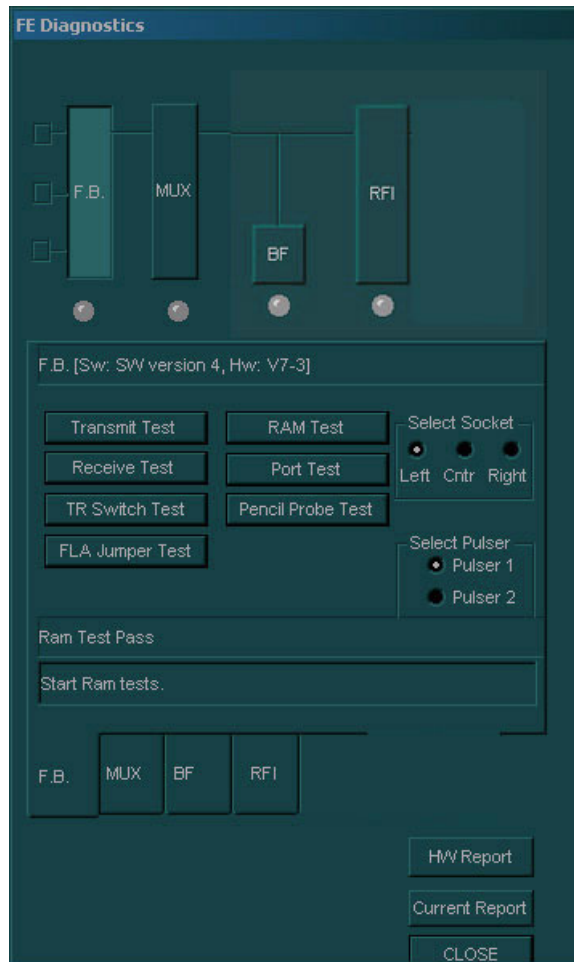

Figure 7-24 F.B. Tab - FE Diagnostics Dialog Box - RAM Test (RFI Configuration)

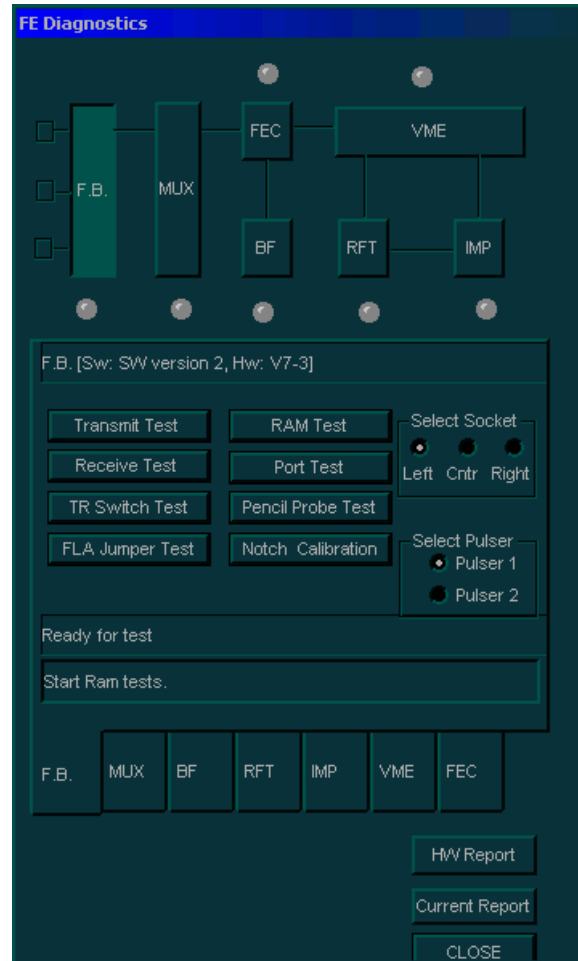

Figure 7-25 F.B. Tab - FE Diagnostics Dialog Box - RAM Test (RFT Configuration)

- 3) Check the test results and proceed as follows:
 - If no errors were identified, proceed with the next test.
 - If no errors were identified but the problem persists, contact your local GE Medical Systems field engineer for assistance.
 - If errors were identified but the results were marginal, perform calibration, as described in the [Calibration](#) section, on page 6-14, and then repeat the test.
 - If errors were identified and the results were not marginal, verify that all image port and PCI bridge cables are connected and functioning properly, as described in [Chapter 5 - Components and Function \(Theory\)](#). If the problem persists, contact your local GE Medical Systems field engineer for assistance.
- 4) Reboot the system.

7-3-9 MUX Diagnostic Tests

NOTE: The **Select Socket** and **Select Supply** options are not relevant for this test.

7-3-9-1 Accessing the MUX Diagnostic Test Options

- 1) Access the *FE Diagnostics* dialog box, as described in the [Accessing the Front End Diagnostic Options](#) section, on page 7-6.
- 2) In the *FE Diagnostics* dialog box, trackball to the **MUX** tab and press **Select**,

OR

Trackball to the **MUX** button in the **Data Flow Maps** and press **Select**. The **MUX** tab is displayed, as shown in [Figure 7-26](#) (or [Figure 7-27](#)) below:

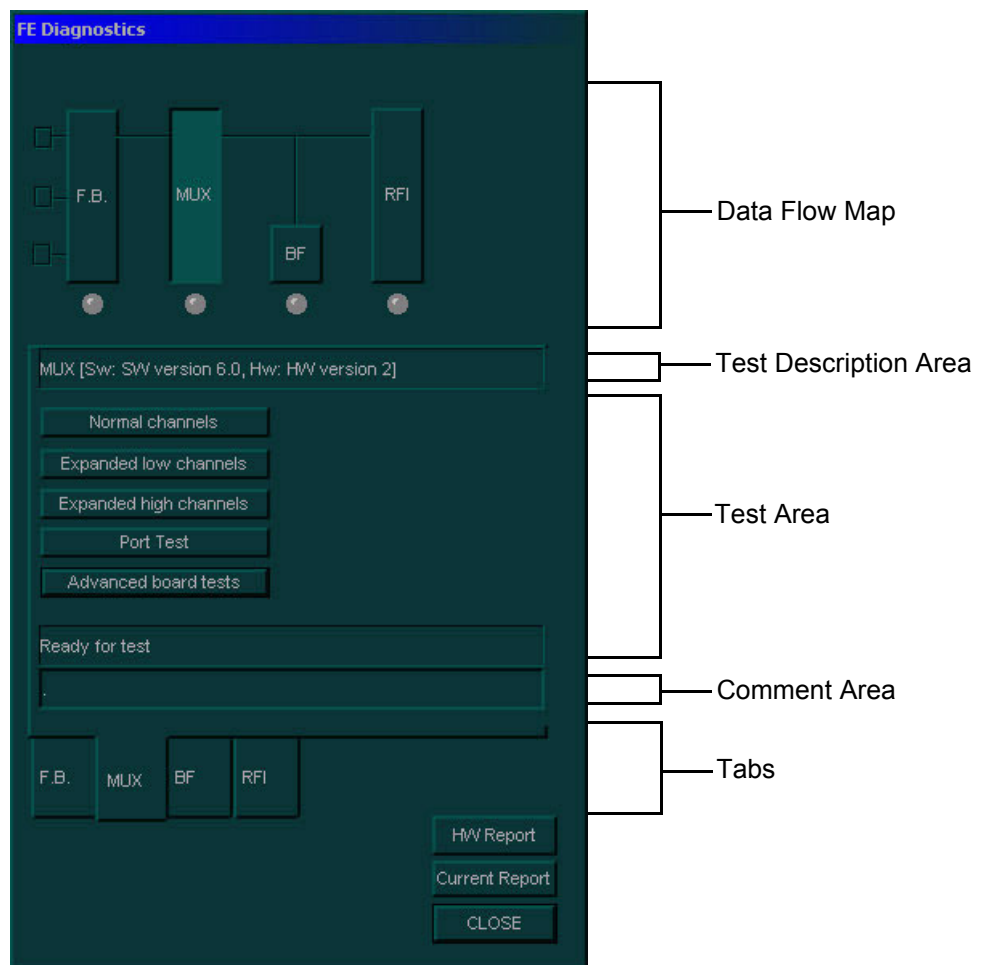

Figure 7-26 MUX Tab - FE Diagnostics Dialog Box (RFI Configuration)

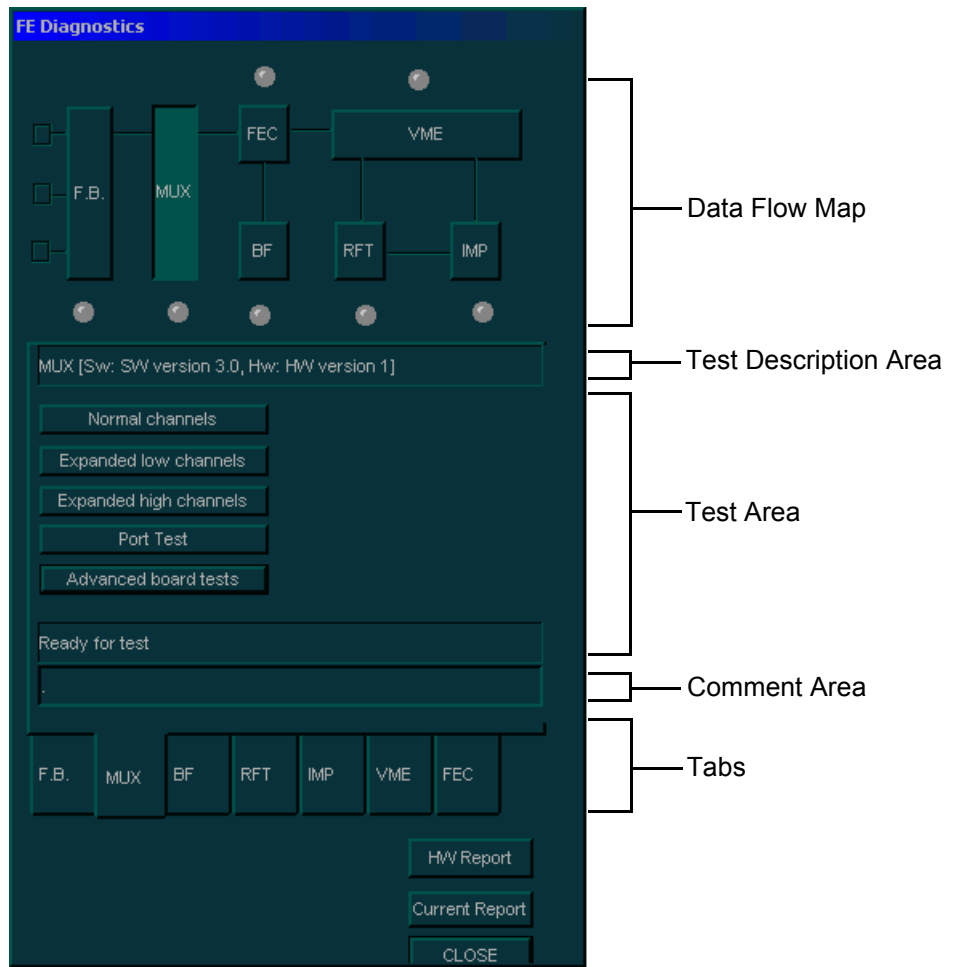

Figure 7-27 MUX Tab - FE Diagnostics Dialog Box (RFT Configuration)

- 3) Trackball to each of the following buttons in turn (in the order stated below) and press **Select** to perform the specific test:
 - **Normal channels:** Test the output channels from the input channels, as described in the [Normal Channels Diagnostic Tests](#) below.
 - **Expanded low channels:** Tests output signals in CW-Mode only, when the input channels are connected to the output channels, as described in the [Expanded Low Channels Diagnostic Tests](#) section, on page 7-54.
 - **Expanded high channels:** Tests the output signals from the input of the high channels, as described in the [Expanded High Channels Diagnostic Tests](#) section, on page 7-55.
 - **Port Test:** Performs a general logic test, as described in the [Port Test](#) section, on page 7-56.
 - **Advanced board tests:** The advanced board tests are described in the [Advanced Board Tests](#) section, on page 7-58. This includes procedure instructions for performing the following tests:
 - [TEE Probe Control](#) on page 7 - 58
 - [AC Power Input Test](#) on page 7 - 60.
 - [LVPS Voltage Test](#) on page 7 - 62.
 - [HVPS Voltage Test](#) on page 7 - 63.
 - [Temp Test](#) on page 7 - 64.
 - [Show History](#) on page 7 - 65.

7-3-9-2 Normal Channels Diagnostic Tests

Tests the output channels from the input channels. This test setting is used for all modes, except CW-Mode.

The Normal Channels Diagnostic Tests check each amplifier output against the predefined output level. This system test is performed in Phased Array Probe Simulation mode. The FEC board injects analog signals to the Tx amplifiers inputs after the Tx switch. The test lasts approximately 4 minutes.

Note: System re-boot is required if the tests are not being performed in the sequence described in the [Performing Front End \(FE\) Diagnostics](#) section, on page 7-5.

- 1) Disconnect all the probes.
- 2) Access the **F.B.** tab of the *FE Diagnostics* dialog box, as described in the [Accessing the Front Board Assembly Options](#) section, on page 7-25.
- 3) Trackball to **Pulsar 1** (High Voltage Power Supply [HVPS] +/-80V) or **Pulsar 2** (Low Voltage Power Supply [LVPS] +/-40V) and press **Select**.

Trackball to the **Normal Channels Test** button and press **Select**. The normal channels diagnostic test is performed, and the test results are displayed in the *Report* dialog box, as shown below:



Figure 7-28 Normal Channels Diagnostic Test

The *Report* dialog box contains the following information:

- **Test Result Message:** Displays the test result.
 - **TR4 Modules:** Displays a graphic representation of the front board (four groups of TR4 sockets). Each group consists of four TR4 sockets, each socket containing four vectors (channels), as follows:
 - Each vector is represented by a button (highlighted in green) that displays the number of the socket to which the TR4 is connected.
 - Each button is highlighted yellow when selected.
 - Each button is highlighted red if errors were detected for one or more channels.
 - **Checkboxes:** Enable you to manipulate bad channels:
 - **Show Only Bad Channels:** Select this checkbox to display only bad channels in the **Display** area.
 - **Mark bad channel:** Select this checkbox to manually mark the currently selected channel as bad.
- 4) Check the test result message and proceed as follows:
- If one or more channels were identified as bad, trackball to the **Save Report** button and press **Select**, then contact a GE Medical Systems Service Representative.
 - If no channels were identified as bad, mark the channels suspected as being bad as follows:
 - Trackball to each of the channels in the **Display** area and press **Select**.
 - Trackball to the **Mark bad channel** checkbox and press **Select**.
 - Trackball to **Save Report** and press **Select**, and contact a GE Medical Systems service representative.
- 5) Trackball to the **Low Freq Test** button and press **Select**. The normal channels diagnostic test is performed in low frequency mode, and the test results are displayed in the *Report* dialog box, as shown in [Figure 7-29](#) on page 7-52:

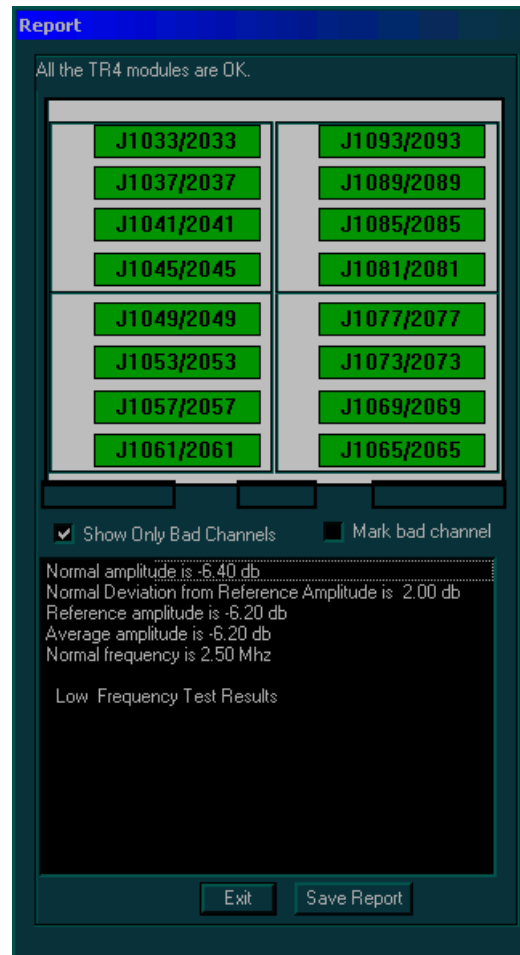

Figure 7-29 Report Dialog Box - Normal Channels Test Low Frequency

The *Report* dialog box contains the following information:

- **Test Result Message:** Displays the test result.
- **TR4 Modules:** Displays a graphic representation of the front board (four groups of TR4 sockets). Each group consists of four TR4 sockets, each socket containing four vectors (channels), as follows:
 - Each vector is represented by a button (highlighted in green) that displays the number of the socket to which the TR4 is connected.
 - Each button is highlighted yellow when selected.
 - Each button is highlighted red if errors were detected for one or more channels.
- **Checkboxes:** Enable you to manipulate bad channels:
 - **Show Only Bad Channels:** Select this checkbox to display only bad channels in the **Display** area.
 - **Mark bad channel:** Select this checkbox to manually mark the currently selected channel as bad.

- 6) Check the test result message and proceed as follows:
 - If one or more channels were identified as bad, trackball to the **Save Report** button and press **Select**, then contact a GE Medical Systems Service Representative.
 - If no channels were identified as bad, mark the channels suspected as being bad as follows:
 - Trackball to each of the channels in the **Display** area and press select.
 - Trackball to the **Mark bad channel** checkbox and press **Select**.
 - Trackball to **Save Report** and press **Select**, and contact a GE Medical Systems service representative.
 - If no errors were identified, proceed with the next test.
 - If no errors were identified but the problem persists, contact your local GE Medical Systems field engineer for assistance.
 - If errors were identified but the results were marginal, perform calibration, as described in the [Calibration](#) section, on page 6-14, and then repeat the test.
 - If errors were identified and the results were not marginal, verify that all image port and PCI bridge cables are connected and functioning properly, as described in [Chapter 5 - Components and Function \(Theory\)](#). If the problem persists, contact your local GE Medical Systems field engineer for assistance.
- 7) Trackball to the **Exit** button and press **Select**. If required, repeat this test with a different pulser.

7-3-9-3 Expanded Low Channels Diagnostic Tests

Tests output signals in CW-Mode only, when the input channels are connected to the output channels. If one channel is missing, the output will be -6db. The input signals come from either a 3S or a 7S probe.



Figure 7-30 Expanded Low Channels Diagnostic Tests

7-3-9-4 Expanded High Channels Diagnostic Tests

Tests the output signals from the input of the high channels. If one channel is missing, the output will be -6db. The input signals come from either a 3S or a 7S probe.



Figure 7-31 Expanded High Channels Diagnostic Tests

7-3-9-5 Port Test

The Port test is a general logic control test.

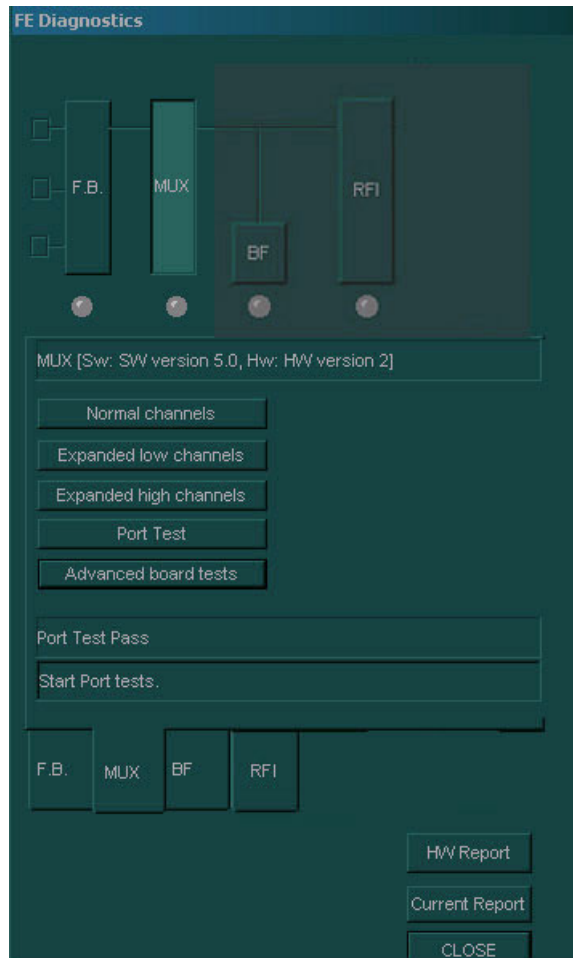

Figure 7-32 Port Test (RFI Configuration)

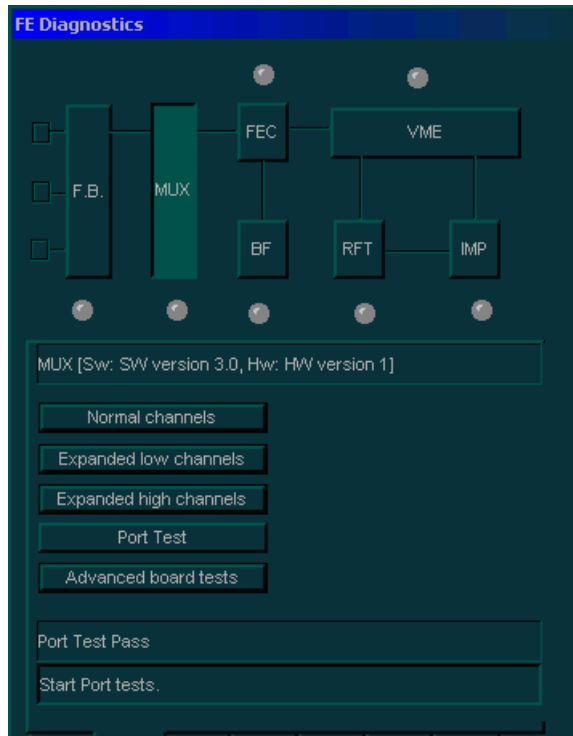

Figure 7-33 Port Test (RFT Configuration)

7-3-9-6 Advanced Board Tests

The advanced board tests check two additional parts of the MUX Board: *TEE probe control* and *Monitoring*, as follows:

- TEE probe control enables you to check different positions of the probe; by changing the probe angle, you are able to verify its normal operation.
- Monitoring enabled you to check the HVPS and LVPS voltages, and the AC Power Input, as well as temperatures.

7-3-9-6-1 TEE Probe Control

The TEE probe control test checks the position setting of the probe, as well as its normal operation.

- 1) Access the MUX tab of the FB Diagnostics dialog box, as described in the [Accessing the MUX Diagnostic Test Options](#) section, on page 7-47.
- 2) Trackball to the **Advanced board tests** button and press **Select**. The *Advanced System Tests* options are displayed, as shown in [Figure 7-34](#) on page 7-58.

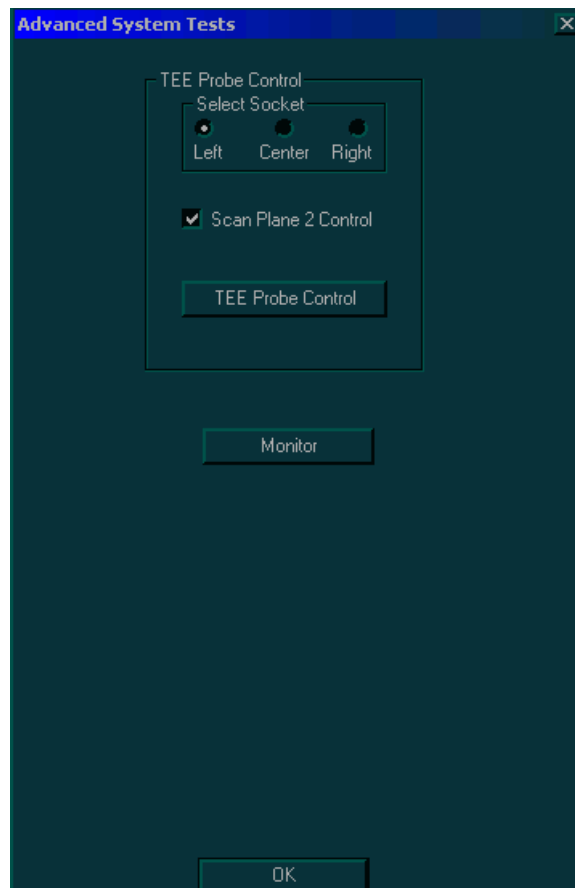

Figure 7-34 MUX Advanced System Tests Options

- 3) Select the radio button next to the appropriate socket.
- 4) Trackball to the **TEE Probe Control** button and press **Select**. The *TEE Probe Test* dialog box is displayed, as shown in [Figure 7-35](#), with all the probe settings.

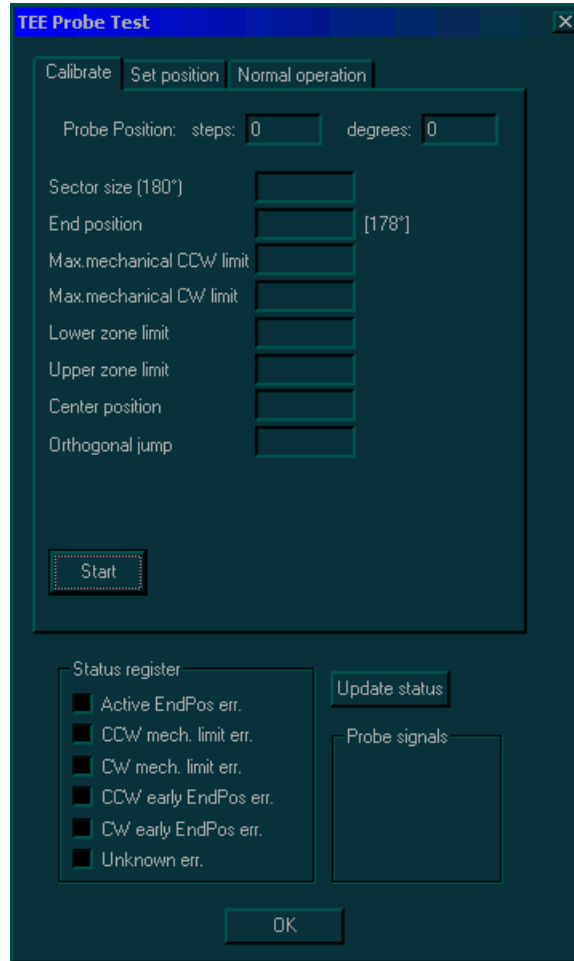

Figure 7-35 TEE Probe Test Dialog Box

- 5) Verify the test results, and then trackball to the **OK** button and press **Select**.

7-3-9-6-2 AC Power Input Test

The AC power input test measures the AC input voltage deviation from the nominal input voltage (accuracy by percentage).

- 1) Access the MUX tab of the FB Diagnostics dialog box, as described in the [Accessing the MUX Diagnostic Test Options](#) section, on page 7-47.
- 2) Trackball to the **Advanced board tests** button and press **Select**. The *Advanced System Tests* options are displayed, as shown in [Figure 7-34](#) on page 7-58.
- 3) Trackball to the **Monitor** button and press **Select**. The *View Power* options are displayed, as shown below:

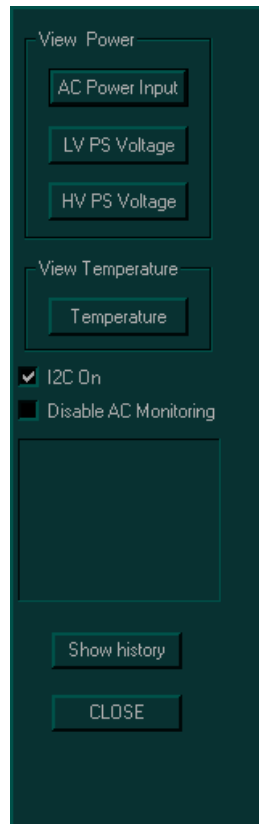

Figure 7-36 View Power Options

- 4) Trackball to the **AC Power Input** button and press **Select**. The *AC Power Input* dialog box is displayed:

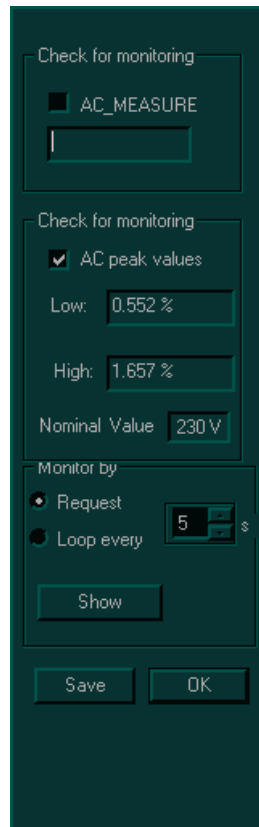

Figure 7-37 AC Power Input Dialog Box

- 5) Trackball to the **Show** button and press **Select** to display the voltage.

Note: For repeat readings, select **Loop every** and set the reading time cycle.

7-3-9-6-3 LVPS Voltage Test

The LVPS test measures the LVPS voltages. The voltage range is displayed next to the measured voltage. All the voltages can be measured with DVM on the front board test point.

- 1) Access the **MUX** tab of the *FB Diagnostics* dialog box, as described in the [Accessing the MUX Diagnostic Test Options](#) section, on page 7-47.
- 2) Trackball to the **Advanced board tests** button and press **Select**. The *Advanced System Tests* options are displayed, as shown in [Figure 7-34](#) on page 7-58.
- 3) Trackball to the **Monitor** button and press **Select**. The *View Power* options are displayed, as shown in [Figure 7-36](#) on page 7-60.
- 4) Trackball to the **LV PS Voltage** button and press **Select**. The LVPS voltage ranges are displayed, as shown below:



Figure 7-38 LVPS Voltage Ranges

- 5) Trackball to the **Show** button and press **Select** to display the voltages.

Note: For repeat readings, select **Loop every** and set the reading time cycle.

7-3-9-6-4 HVPS Voltage Test

The HVPS test measures the Tx voltages. The current values are displayed next to the measured values. All the voltages can be measured with DVM on the front board test point.

Note: The Tx voltage may vary according to the operating mode.

- 1) Access the **MUX** tab of the *FB Diagnostics* dialog box, as described in the [Accessing the MUX Diagnostic Test Options](#) section, on page 7-47.
- 2) Trackball to the **Advanced board tests** button and press **Select**. The *Advanced System Tests* options are displayed, as shown in [Figure 7-34](#) on page 7-58.
- 3) Trackball to the **Monitor** button and press **Select**. The *View Power* options are displayed, as shown in [Figure 7-36](#) on page 7-60.
- 4) Trackball to the **HV PS Voltage** button and press **Select**. The Tx voltages are displayed, as shown below:

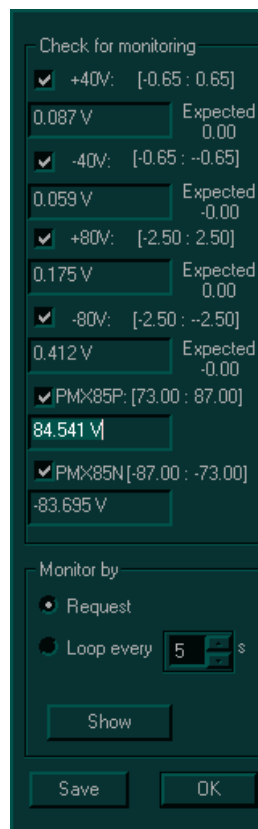

Figure 7-39 HVPS Voltage Ranges

- 5) Trackball to the **Show** button and press **Select** to display the voltages.

Note: For repeat readings, select **Loop every** and set the reading time cycle.

7-3-9-6-5 Temp Test

The Temp test displays the temperature at the Front End crate, as well as the temperature of the AC distribution box.

- 1) Access the **MUX** tab of the *FB Diagnostics* dialog box, as described in the [Accessing the MUX Diagnostic Test Options](#) section, on page 7-47.
- 2) Trackball to the **Advanced board tests** button and press **Select**. The *Advanced System Tests* options are displayed, as shown in [Figure 7-34](#) on page 7-58.
- 3) Trackball to the **Monitor** button and press **Select**. The *View Power* options are displayed, as shown in [Figure 7-36](#) on page 7-60.
- 4) Trackball to the **Temperature** button and press **Select**. The temperatures are displayed, as shown below:

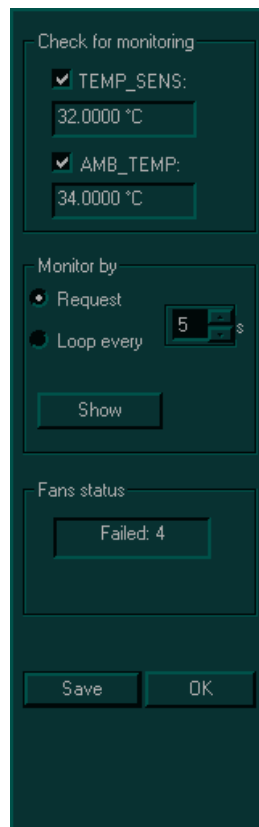

Figure 7-40 Temperatures

- 5) Trackball to the **Show** button and press **Select** to display the temperatures.

Note: For repeat readings, select **Loop every** and set the reading time cycle.

7-3-9-6-6 Show History

The **Show History** option in the *View Power* dialog box displays selected test results by *year*, *month* and *day*.

- 1) Access the **MUX** tab of the *FB Diagnostics* dialog box, as described in the [Accessing the MUX Diagnostic Test Options](#) section, on page 7-47.
- 2) Trackball to the **Advanced board tests** button and press **Select**. The *Advanced System Tests* options are displayed, as shown in [Figure 7-34](#) on page 7-58.
- 3) Trackball to the **Monitor** button and press **Select**. The *View Power* options are displayed, as shown in [Figure 7-36](#) on page 7-60.
- 4) Trackball to the **View History** button and press **Select**. The following options are displayed.

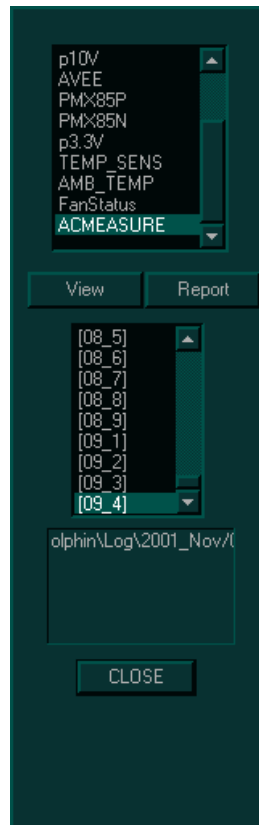

Figure 7-41 View History Options

- 5) Select the test and date that you want to view from the appropriate drop-down list, then trackball to the **View** button and press **Select**. The relevant graphs are displayed showing activity over time in values of *Temperature*, *%*, or *Voltage*.

7-3-10 H/W Report

The **H/W Report** button in the *FE Diagnostics* dialog box enables you to generate a report displaying the Front End boards, software versions and hardware revisions.

- 1) Access the *FE Diagnostics* dialog box, as described in the [Accessing the Front End Diagnostic Options](#) section, on page 7-6.
- 2) Trackball to the **H/W Report** button and press **Select**. The *System Report* window is displayed, as shown below:

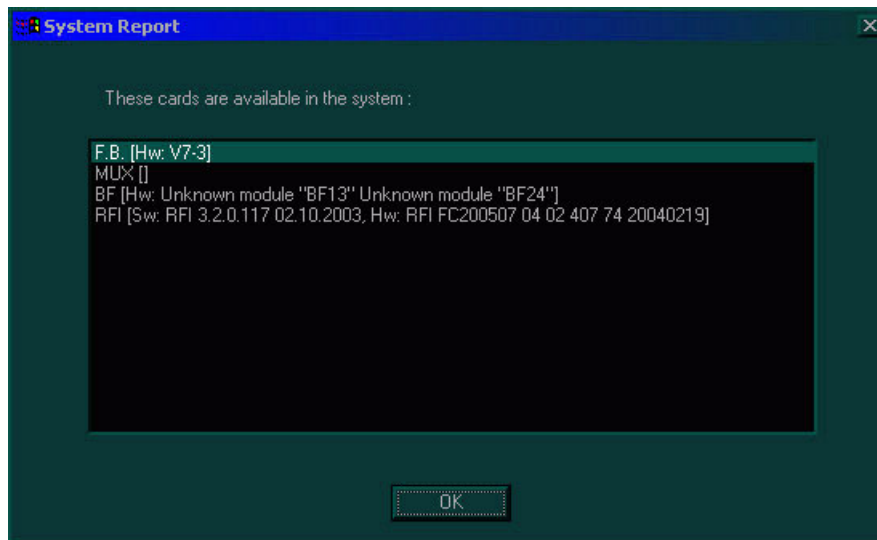

Figure 7-42 System Report Window (RFI-configured Systems)

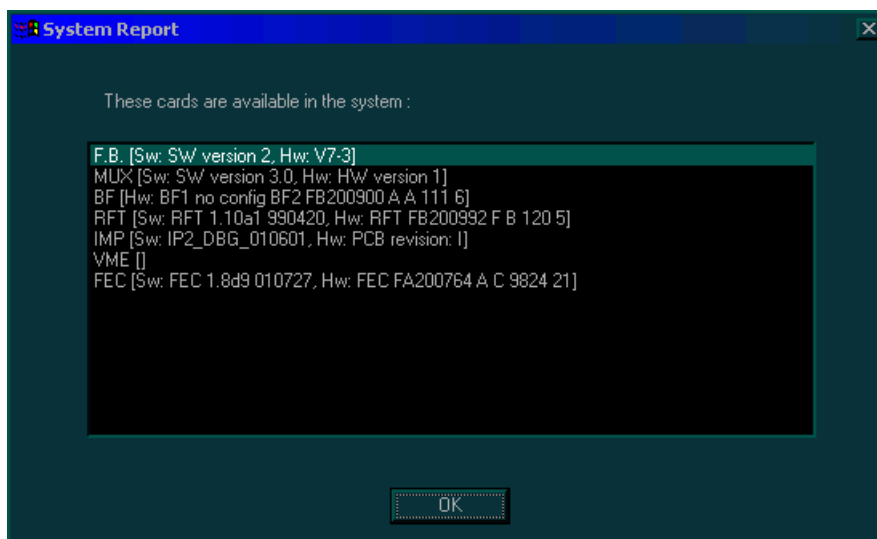

Figure 7-43 System Report Window (RFT-configured Systems)

7-3-11 Current Report

The **H/W Report** button in the *FE Diagnostics* dialog box enables you to generate a report of the current test and failure results.

- 1) Access the *FE Diagnostics* dialog box, as described in the [Accessing the Front End Diagnostic Options](#) section, on page 7-6.
- 2) Trackball to the **Current Report** button and press **Select**. The *Current Report* window is displayed, as shown below:

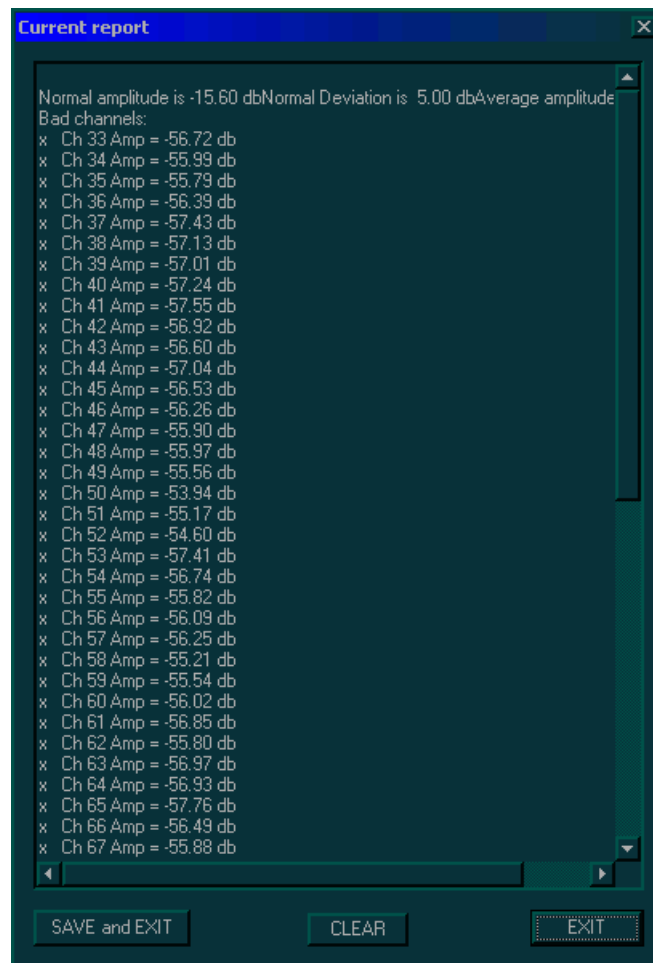

Figure 7-44 Current Report Window

Section 7-4 Performing Back End Diagnostics on the System

The Back End Diagnostics enable you to test the functionality of various Back End hardware components.

Note: The Back End Diagnostic Tests may be performed independently, regardless of sequence.

7-4-1 Accessing the Back End Diagnostic Options

- 1) In 2D-Mode, press **<Ctrl+F11>** on the alphanumeric keyboard. The *Diagnostic* menu is displayed, as shown in [Figure 7-1](#) on page 7-3.
- 2) In the *Diagnostic* menu, trackball to the **Back End** button and press **Select**. The *HW Diagnostics* menu is displayed, as shown below:

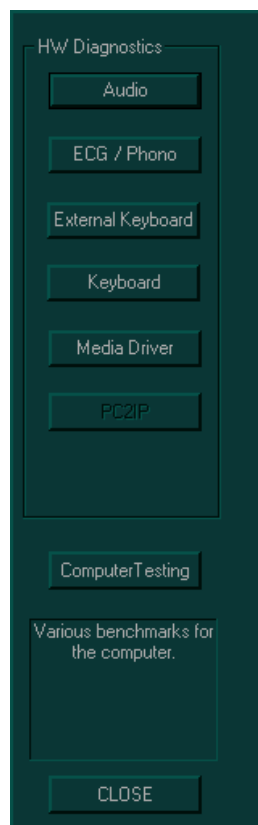

Figure 7-45 Back End Diagnostics Options

Note: The following test options are available in the *HW Diagnostics* menu. These tests may be performed independently, regardless of sequence.

- **Audio:** Enables you to test the doppler sound, as described in the [Audio \(Doppler Sound Driver\) Diagnostic Test](#) section, on page 7-70.
- **ECG / Phono:** Enables you to test the ECG and Phono options, as described in the [ECG/ Phono Diagnostic Test](#) section, on page 7-71.
- **External Keyboard:** Enables you to test the keyboard options and lights in different modes, as described in the [External Keyboard Diagnostic Test](#) section, on page 7-73.
- **Keyboard:** Enables you to test the alphanumeric keyboard keys, as described in the [Keyboard Diagnostic Test](#) section, on page 7-76.
- **Media Driver:** Enables you to test the functionality of the media driver, if available, as described in the [Media Driver Diagnostic Test](#) section, on page 7-77.
- **Computer Testing:** Enables you to test the functionality of various modes, as described in the [Computer Diagnostic Test](#) section, on page 7-79.

7-4-2 Audio (Doppler Sound Driver) Diagnostic Test

The audio test enables you to test the Doppler sound at different PRFs and frequencies.

- 1) Access the *HW Diagnostics* menu, as described in the [Accessing the Back End Diagnostic Options](#) section, on page 7-68.
- 2) Trackball to the **Audio** button and press **Select**. The *DopSound Driver Tester* dialog box is displayed, as shown below.

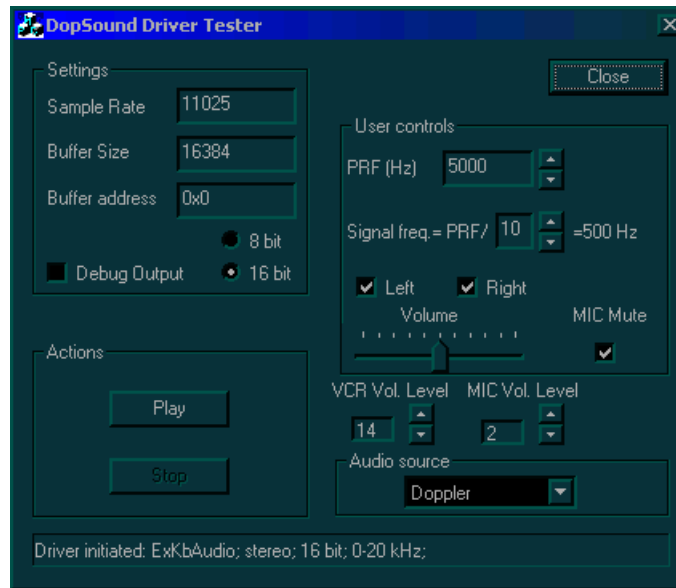

Figure 7-46 DopSound Driver Tester Dialog Box

Note: The audio tests are performed for each of the speakers, at various PRFs and frequencies. Left and right are as seen when standing behind the unit.

- 3) In the **User controls** area, trackball to the **Right** radio button and press **Select** to test the right speaker. Ensure that the left speaker is deselected.
- 4) In the **Actions** area, trackball to the **Play** button and press **Select**. Verify that a clear tone is emitted.
- 5) In the **User controls** area, change the PRF.
- 6) Trackball to the **Play** button in the **Actions** area and press **Select** to test the speaker activity at the new frequency. Verify that a clear tone is emitted.
- 7) Repeat steps 5 and 6 for the right speaker at a variety of frequencies.
- 8) Repeat steps 3 through 7 for the left speaker.
- 9) When you are finished, trackball to the **Close** button and press **Select**.

7-4-3 ECG/Phono Diagnostic Test

The ECG and Phono tests enable you to check the output of the ECG and Phono options.

7-4-3-1 ECG Diagnostic Test

- 1) Connect the internal ECG input to yourself or to an appropriate ECG simulator, using the cable set and electrode pads.

Note: The external ECG can also be tested when the electrodes are connected to yourself or to an appropriate ECG simulator. In this case, select the **External ECG** radio button in the *TestECGDevice* dialog box.

- 2) Access the *HW Diagnostics* menu, as described in the [Accessing the Back End Diagnostic Options](#) section, on page 7-68.
- 3) Trackball to the **ECG / Phono** button and press **Select**. The *TestECGDevice* dialog box is displayed, as shown below:

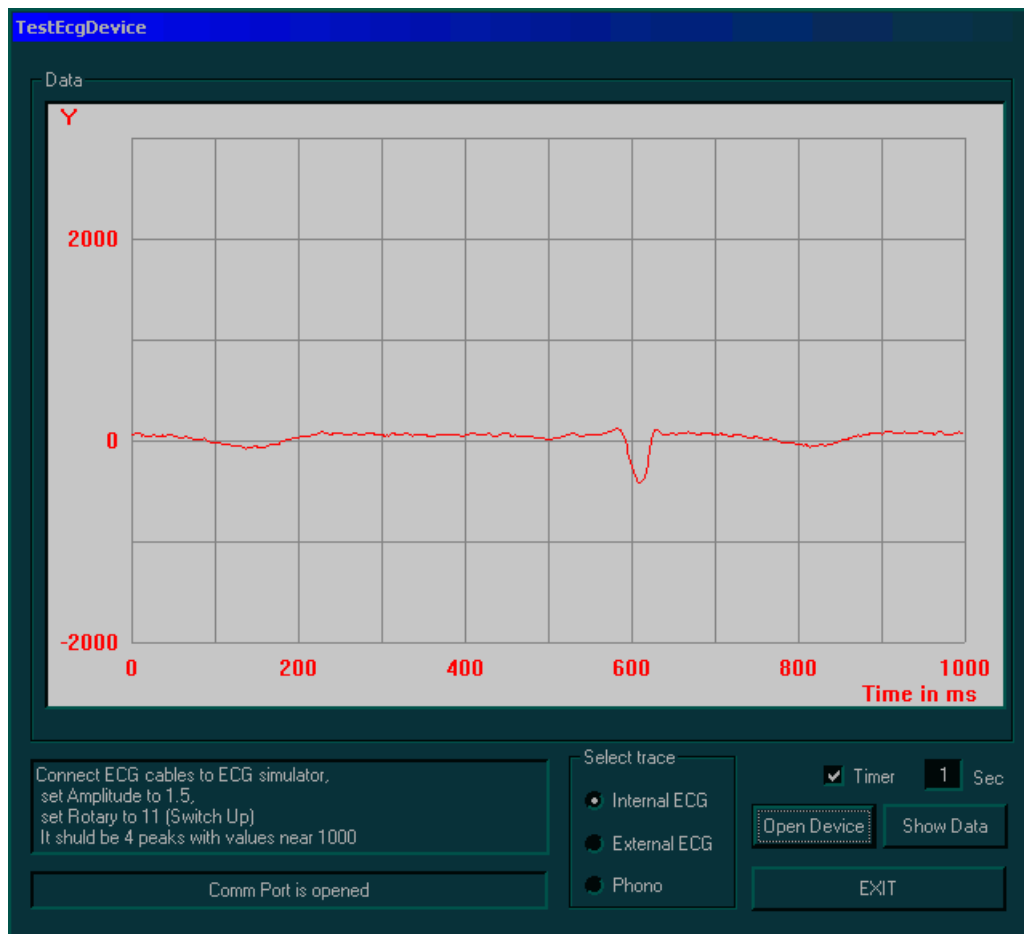

Figure 7-47 Test ECG Device Dialog Box

- 4) In the **Select trace** area, trackball to the **Internal ECG** radio button and press **Select**.
- 5) Trackball to the **Open Device** button and press **Select**. The ECG signal is displayed in the **Data** area. Verify that a single, clear QRS signal is displayed.
- 6) When you are finished, trackball to the **EXIT** button and press **Select**.

7-4-3-2 Phono Test

- 1) Connect the media microphone to the microphone input on the ECG board.
- 2) Access the *HW Diagnostics* menu, as described in the [Accessing the Back End Diagnostic Options](#) section, on page 7-68.
- 3) Trackball to the **ECG / Phono** button and press **Select**. The *TestECGDevice* dialog box is displayed, as shown in [Figure 7-47](#) on page 7-71.
- 4) In the **Select trace** area, trackball to the **Phono** radio button and press **Select**.
- 5) Trackball to the **Open Device** button and press **Select**.
- 6) Use your finger to click the microphone. The Phono signal is displayed in the data area. Verify that the waveform on the screen corresponds to the microphone clicks.
- 7) When you are finished, trackball to the **EXIT** button and press **Select**.

7-4-4 External Keyboard Diagnostic Test

The external keyboard diagnostic tests enable you to test the buttons and lights on the keyboard in different modes.

Note: To test the keys on the alphanumeric keyboard, refer to the [Keyboard Diagnostic Test](#) section, on page 7-76.

7-4-4-1 Manual External Keyboard Test

- 1) Access the *HW Diagnostics* menu, as described in the [Accessing the Back End Diagnostic Options](#) section, on page 7-68.
- 2) Trackball to the **External Keyboard** button and press **Select**. The *Extended Keyboard Test* window is displayed, as shown below:

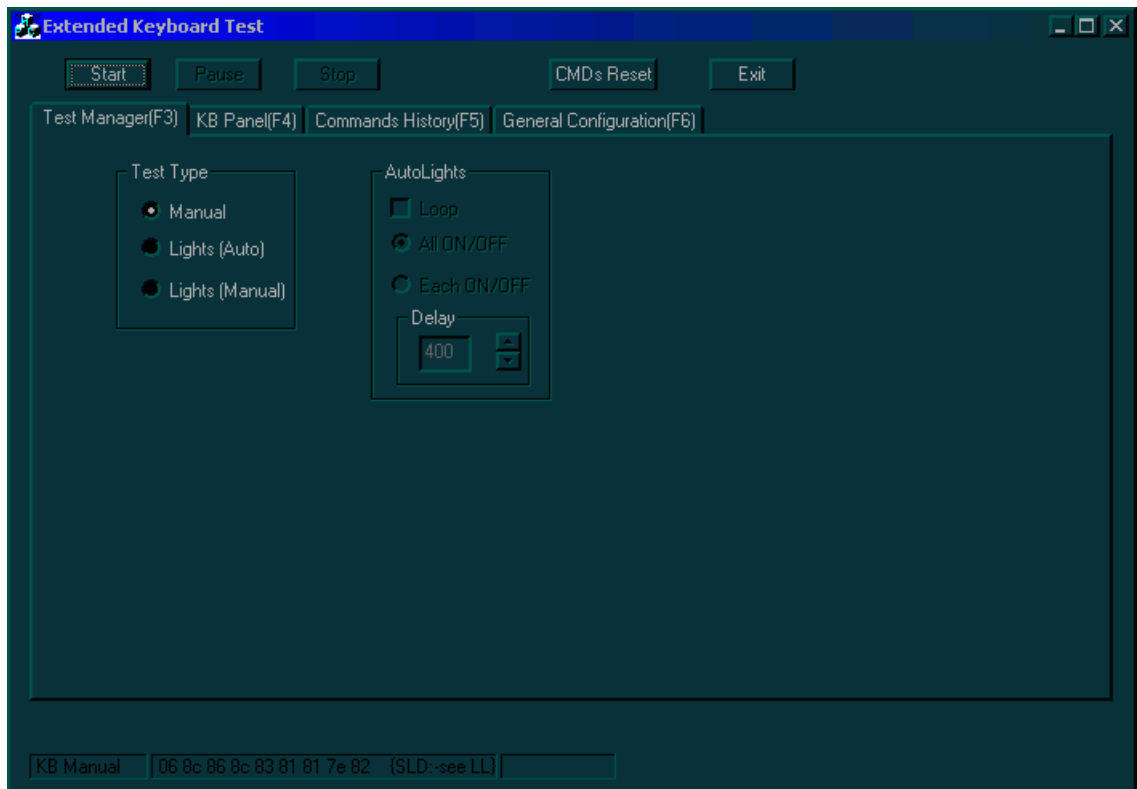

Figure 7-48 Test Manager Tab - Extended Keyboard Test Window

- 3) In the **Test Manager** tab, trackball to the **Manual** radio button and press **Select**.
- 4) Trackball to the **KB Panel** tab and press **Select**. The **KB Panel** tab is displayed, as shown in [Figure 7-49](#) on page 7-74.

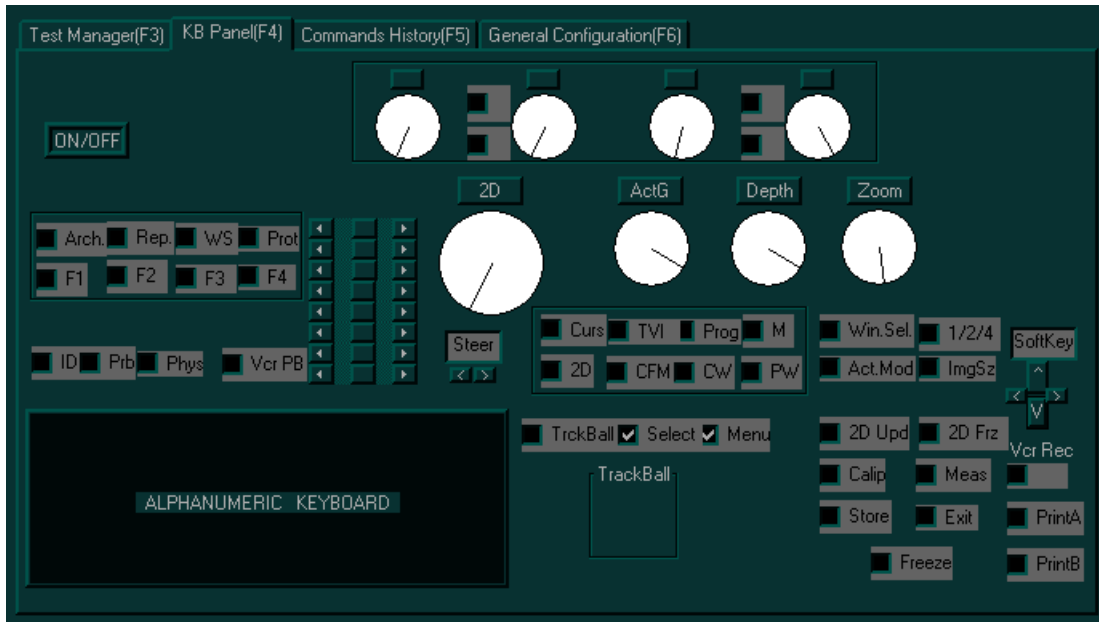

Figure 7-49 KB Panel Tab - Extended Keyboard Test Window

- 5) Press each of the control panel buttons (except for **Select**, **Menu** and the **On/Off** button), and verify that the correct buttons are activated on-screen in the **KB Panel** tab.
- 6) Push each of the rocker switches, and verify that the correct rockers are activated on-screen in the **KB Panel** tab.
- 7) Rotate each of the rotaries, and verify that the correct rotaries are activated on-screen in the **KB Panel** tab.
- 8) Slide each of the sliders, and verify that only the correct sliders are activated on-screen in the **KB Panel** tab.
- 9) Press the soft keys, and verify that only the correct soft keys are activated on-screen in the **KB Panel** tab.
- 10) Connect the Footswitch to the connector on the front panel of the unit, and press the right, middle and left of the switch. Verify that the numbers {68}, {69} and {70} accordingly are displayed on the info bar.
- 11) When you are finished, trackball to the **Exit** button and press **Select**.

7-4-4-2 Automatic Lights Test

- 1) Access the *HW Diagnostics* menu, as described in the [Accessing the Back End Diagnostic Options](#) section, on page 7-68.
- 2) Trackball to the **External Keyboard** button and press **Select**. The *Extended Keyboard Test* window is displayed, as shown in [Figure 7-48](#) on page 7-73.
- 3) In the **Test Manager** tab, trackball to the **Lights (Auto)** radio button and press **Select**.
- 4) Trackball to the **Start** button and press **Select**. Verify that all the LEDs are illuminated.
- 5) Press the **Preset** button on the keyboard, and then trackball to the **Start** button and press **Select**. Ensure that the **Select** checkbox is selected in the **KB Panel** tab. Verify that all the backlights on the alphanumeric and extended keyboards are illuminated.
- 6) When you are finished, trackball to the **Exit** button and press **Select**.

7-4-4-3 Manual Lights Test

- 1) Access the *HW Diagnostics* menu, as described in the [Accessing the Back End Diagnostic Options](#) section, on page 7-68.
- 2) Trackball to the **External Keyboard** button and press **Select**. The *Extended Keyboard Test* window is displayed, as shown in [Figure 7-48](#) on page 7-73.
- 3) In the **Test Manager** tab, trackball to the **Lights (Manual)** radio button and press **Select**.
- 4) In the **KB Panel** tab, deselect the **Select** checkbox. Verify that after the **Select** LED is off, the alphanumeric keyboards LEDs are dimmed.
- 5) When you are finished, trackball to the **Exit** button and press **Select**.

7-4-4-4 Commands History

Select the **Commands History** tab in the *Extended Keyboard Test* window to view a report of the activity of the extended control panel during the test, as shown below:

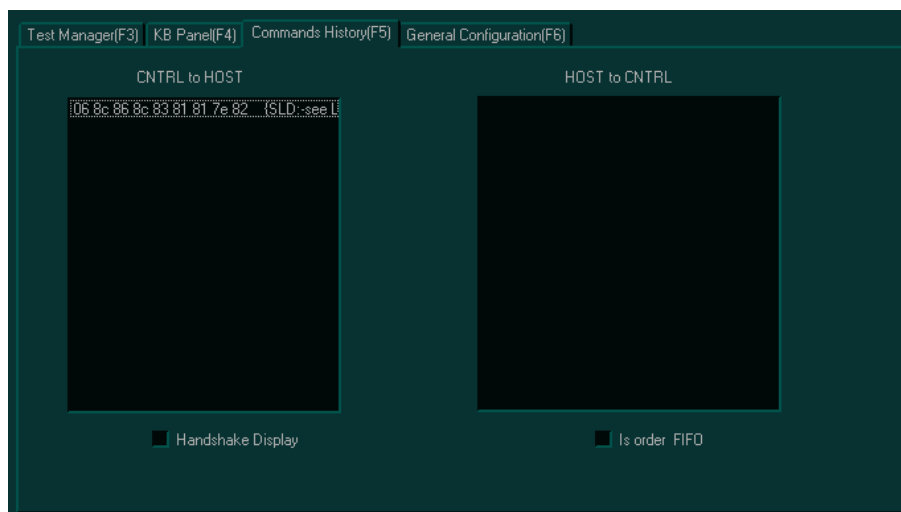

Figure 7-50 Commands History Tab - Extended Keyboard Test Window

7-4-4-5 General Configuration

Select the **General Configuration** tab in the *Extended Keyboard Test* window to set the type of log files that is generated, for example an error log or no log at all.

7-4-5 Keyboard Diagnostic Test

The keyboard diagnostic test enables you to check the functionality of the alphanumeric keyboard keys.

- 1) Access the *HW Diagnostics* menu, as described in the [Accessing the Back End Diagnostic Options](#) section, on page 7-68.
- 2) Trackball to the **Keyboard** button and press **Select**. The *Keyboard Test* dialog box is displayed, as shown below:

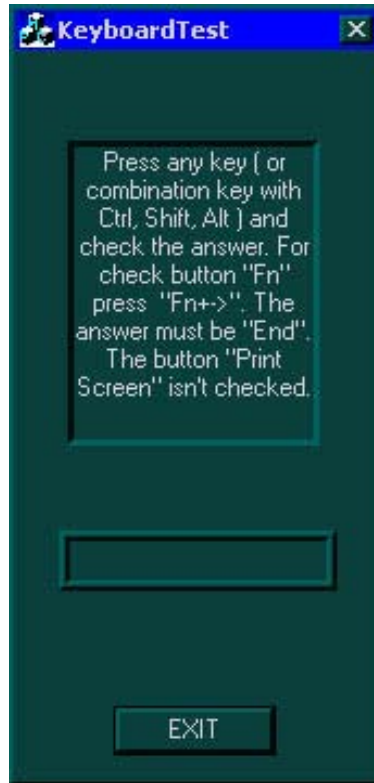

Figure 7-51 Keyboard Test Dialog Box

- 3) Follow the on-screen instructions.
- 4) When you are finished, trackball to the **Close** button and press **Select**.

7-4-6 Media Driver Diagnostic Test

The media driver diagnostic test enables you to check the functionality of the MOD, if installed, as well as the functionality of the CD Writer, if installed.

7-4-6-1 MOD Diagnostic Test



WARNING: Do not run an MOD Diagnostic Test on MO media that is being used by the customer as a back-up device, since this test may cause unrecoverable damage to any backed-up patient information on the MO media.

- 1) Insert a new MO Media Sony EDM-2300B (2.3G) into the MOD.
- 1) Access the *HW Diagnostics* menu, as described in the [Accessing the Back End Diagnostic Options](#) section, on page 7-68.
- 2) Trackball to the **Media Driver** button and press **Select**. The *Util_MO_CDR_App* dialog box is displayed, as shown below:

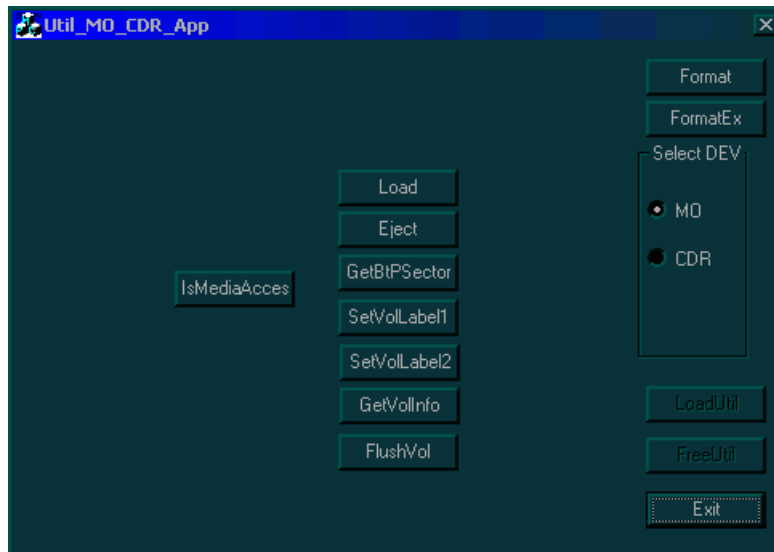

Figure 7-52 Util_MO_CDR_App Dialog Box

- 3) Trackball to the **MO** radio button and press **Select**.
- 4) Trackball to the **IsMediaAccess** button and press **Select**. The message **Media in drive G is accessible** is displayed.
- 5) Trackball to the **Eject** button and press **Select**. The message **Media is outside** is displayed. Verify that the media has actually been ejected.
- 6) Trackball to the **Load** button and press **Select**. The message **Media is inside** is displayed. Verify that the media is actually inside.
- 7) Trackball to the **Format** button and press **Select**. The message **Media in drive G was formatted successfully** is displayed.
- 8) Trackball to the **GetVolInfo** button and press **Select**. The message **Media in drive G has following properties: Media Label = MY_LABEL, Media File-System Name = FAT** is displayed.
- 9) Trackball to the **GetBtPSector** button and press **Select**. The message **The Bytes Per Sector value of media in drive G is 512** is displayed.
- 10) Trackball to the **SetVolLabel1** button and press **Select**. The message **Media Label set to TEST_LABEL1** is displayed.

- 11) Trackball to the **<GetVollInfo>** button and press **Select**. The message **Media in drive G has following properties: Media Label = TEST_LABEL, Media File-System Name = FAT** is displayed.
- 12) Trackball to the **Exit** button and press **Select**.

7-4-6-2 CD Writer Diagnostic Test

- 1) Insert a new recordable CD X16 in the CDR drive.
- 2) Access the *HW Diagnostics* menu, as described in the [Accessing the Back End Diagnostic Options](#) section, on page 7-68.
- 3) Trackball to the **Media Driver** button and press **Select**. The *Util_MO_CDR_App* dialog box is displayed, as shown in [Figure 7-52](#) on page 7-77.
- 4) Trackball to the **CDR** radio button and press **Select**.
- 5) Trackball to the **IsMediaAccess** button and press **Select**. The message **Media in drive H is accessible** is displayed.
- 6) Trackball to the **Eject** button and press **Select**. The message **Finalize Media?** is displayed.
- 7) Select **No**. The message **Media is outside** is displayed. Verify that the media has actually been ejected.
- 8) Trackball to the **Load** button and press **Select**. The message **Media is inside** is displayed. Verify that the media is actually inside.
- 9) Trackball to the **Format** button and press **Select**. The message **Media in drive H was formatted successfully** is displayed.
- 10) Trackball to the **GetVollInfo** button and press **Select**. The message: **Media in drive H has following properties: Media Label = MY_LABEL, Media File-System Name = CDUDF** is displayed.
- 11) Trackball to the **GetBtPSector** button and press **Select**. The message **The Bytes Per Sector value of media in drive H is 2048** is displayed.
- 12) Trackball to the **SetVolLabel1** button and press **Select**. The message **Media Label set to TEST_LABEL2** is displayed.
- 13) Trackball to the **GetVollInfo** button and press **Select**. The message **Media in drive H has following properties: Media Label = TEST_LABEL2, Media File-System Name = CDUDF** is displayed.
- 14) Trackball to the **FlushVol** button and press **Select**. The message **The cached data is flushed to the volume in drive H** is displayed.
- 15) Trackball to the **Exit** button and press **Select**.

7-4-7 Computer Diagnostic Test

The computer diagnostic tests enable you to perform a benchmark test for the correct frame rate, as well as check the memory usage.

7-4-7-1 Benchmark Testing

- 1) Access the *HW Diagnostics* menu, as described in the [Accessing the Back End Diagnostic Options](#) section, on page 7-68.
- 2) Trackball to the **Computer Testing** button and press **Select**. The following options are displayed:

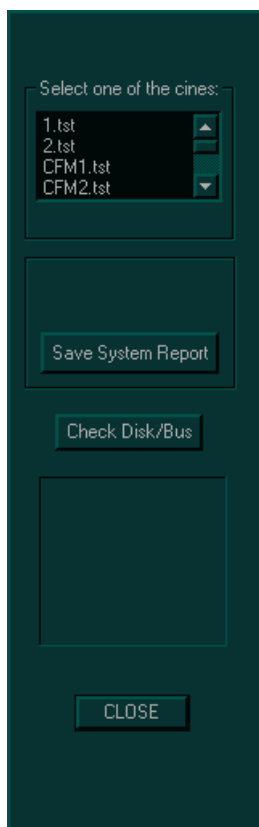

Figure 7-53 Benchmark Testing Options

- 3) Trackball to the required option from the **Select one of the cines** drop-down list and press **Select**. The following results are displayed, as shown in [Figure 7-54](#) on page 7-80.

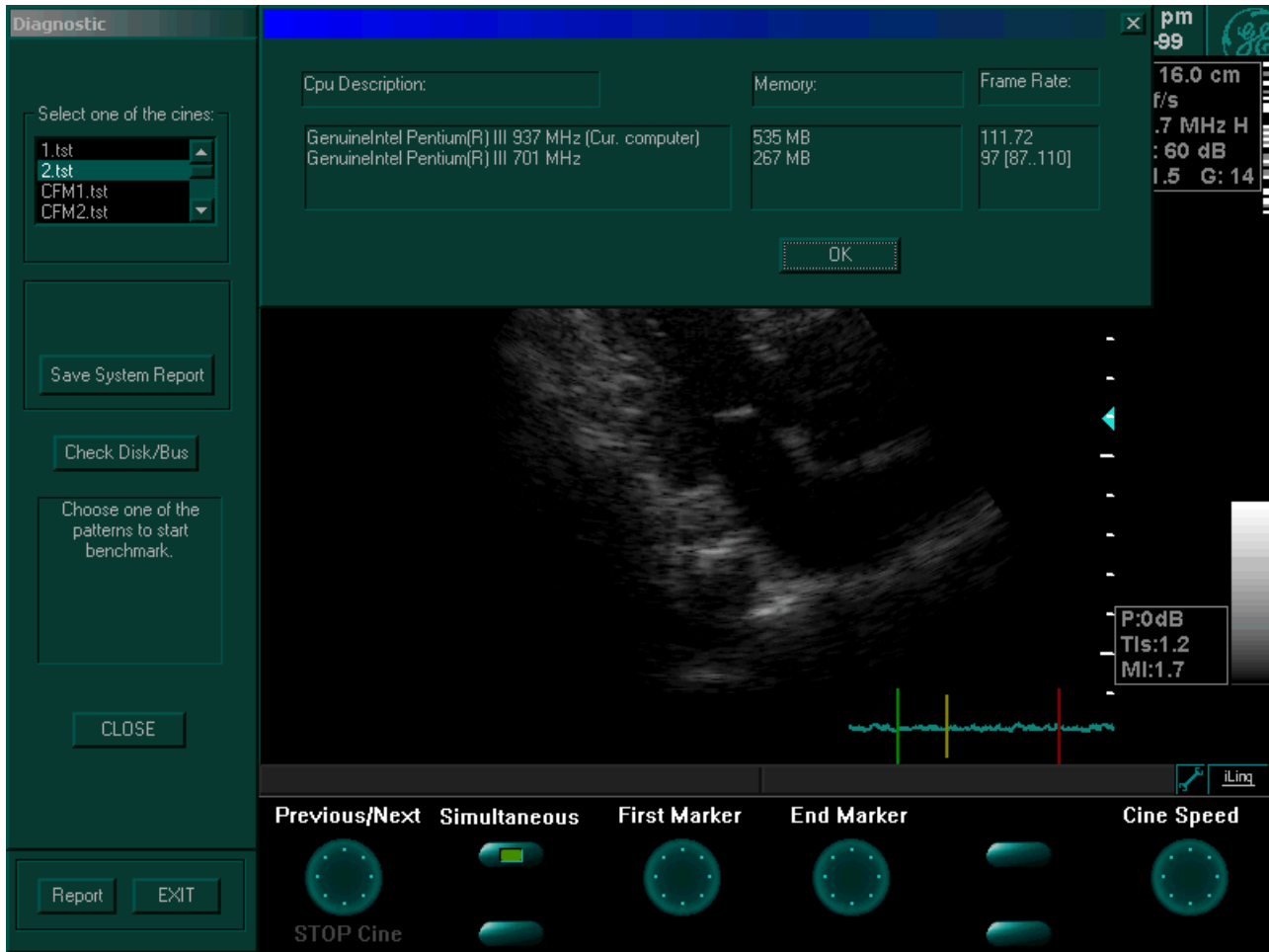

Figure 7-54 Benchmark Testing Results

In the information displayed under *CPU Description*, *Memory* and *Frame Rate*, make sure that the values displayed in the upper line (which indicates current computer results) are higher or equal to those indicated in the lower line.

7-4-7-2 Check Disk/Bus

- 1) Access the *HW Diagnostics* menu, as described in the [Accessing the Back End Diagnostic Options](#) section, on page 7-68.
- 2) Trackball to the **Computer Testing** button and press **Select**. The options shown in [Figure 7-53](#) on page 7-79 are displayed.
- 3) Trackball to the **Check Disc/Bus** button and press **Select**. The **Disk/Bus Bench** window is displayed as shown in [Figure 7-55](#) on page 7-81.

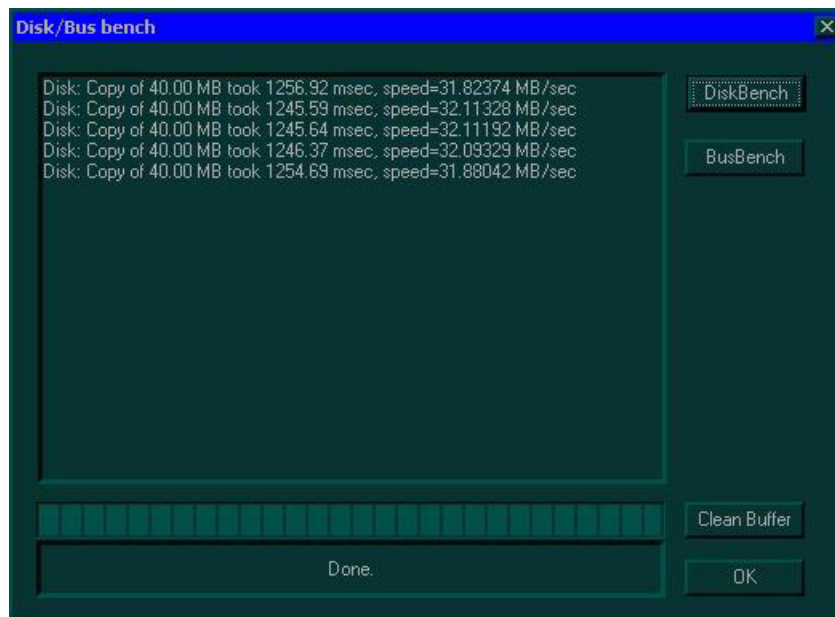

Figure 7-55 Disk/Bus Bench Window

Disk Bench: In the information displayed, make sure that the speed values displayed are greater than 23MB/sec. This test checks the speed of information transfer between the hard disk and IDE BUS.

Bus Bench: In the information displayed, make sure that the speed values displayed are greater than 86MB/sec. This test checks the speed of information transfer between the memory and the BUS.

7-4-8 UPS Test

The UPS Test is used to verify proper operation of the uninterruptible power supply (UPS) and its connection to the system. This procedure is performed in *Standby Mode*.

- 1) Hold down the ON/OFF button on the control console for more than 3 seconds.

The Shutdown Options screen is displayed, as shown in [Figure 7-56](#).

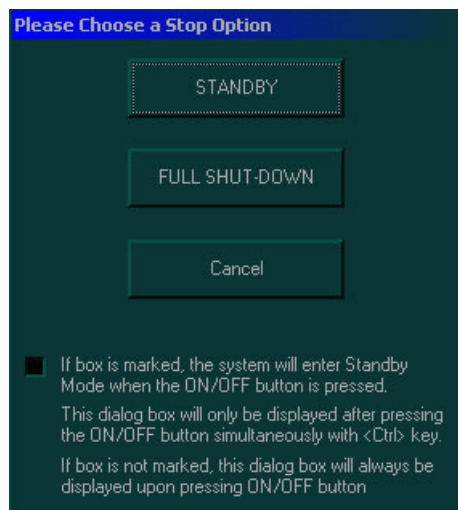

Figure 7-56 Shut-Down Options Screen

- 2) Trackball to **Standby** and press **Select**.

The system enters Standby mode. The light on the ON/OFF button on the control console blinks repeatedly.

- 3.) Disconnect the AC power cable from the mains wall power outlet.
- 4.) Check that the ON/OFF button on the control console blinks repeatedly (the system is now powered by the UPS).
- 5.) Leave the system in this state for a period of 20 minutes, checking that the ON/OFF button continues to blink during this time (indicating correct operation of the UPS).
- 6.) Reconnect the AC power cable to the mains wall power outlet.
- 7.) Hold down the ON/OFF button on the control console for more than 3 seconds.

The system quickly re-boots and is ready for scanning.

7-4-9 Checking the Network Adaptors from Windows Device Manager

NOTE: This check is performed on the system while in Technical Support Mode, as described below. Make sure the T-plug (dongle) is inserted into the parallel or USB port on the Vivid™ 3 rear connectors panel.

- 1) Turn ON the system by pressing the ON/OFF button on the control console and re-boot into Technical Support Mode using the T-plug.

While re-booting the system, be prepared to select **Technical Support Mode** when prompted, then press **<Enter>**.

- 2.) From the Windows desktop, select **Start > Programs > Computer Management > Device Manager > Network Adaptors**, as shown below.

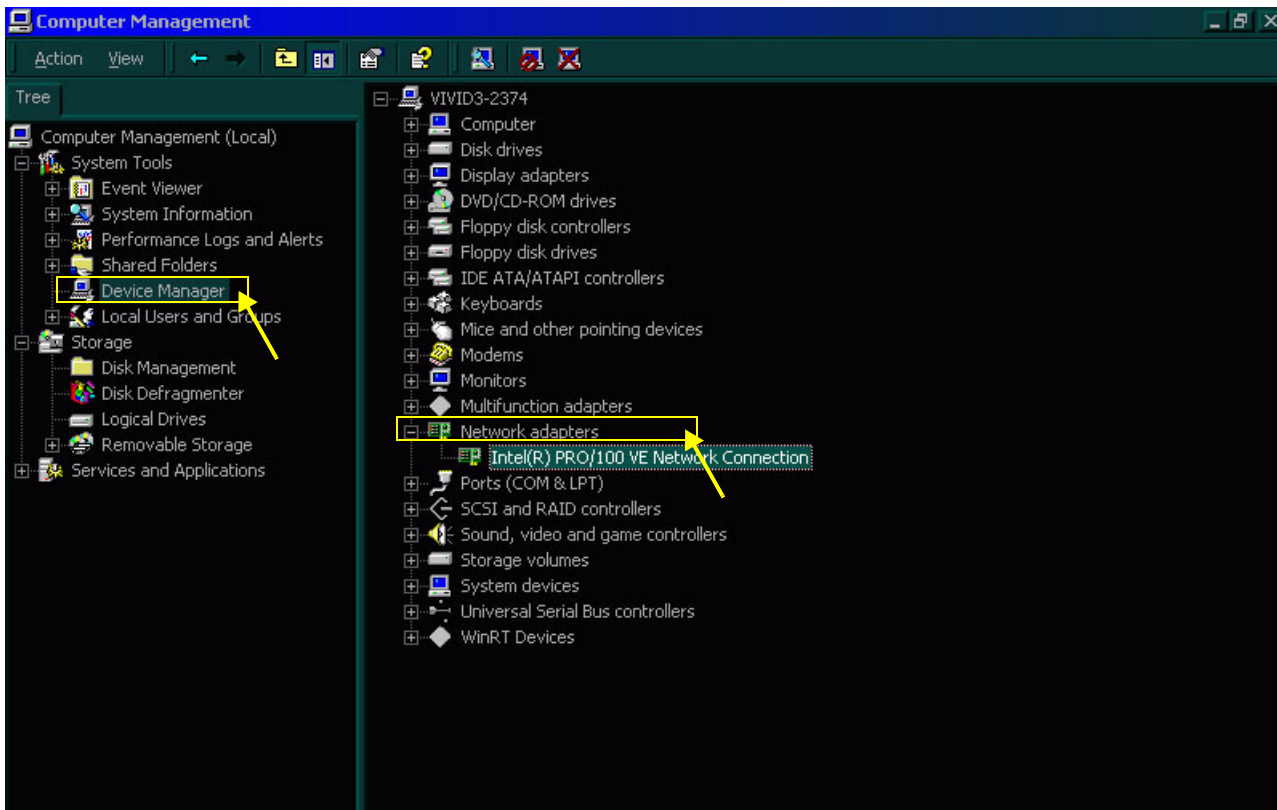

Figure 7-57 Checking the Network Adaptors

- 3.) Make sure that the **Intel(R) PRO/100VE Network Connection** is indicated as shown in [Figure 7-57](#), above.

Section 7-5 Common Service Interface

NOTE: The Common Service Interface uses the Windows version of PC-Doctor.

The Service Platform contains a set of software modules that are common to many of GE Medical Systems' ultrasound and cardiology systems. This web-enabled technology provides linkage to e-Services, e-Commerce and the iCenter, making GE Medical Systems' scanners more e-enabled than ever.

7-5-1 iLinq Interactive Platform Features

Many of the services of the Common Service Platform come from its integration with iLinq. The following list briefly describes iLinq's features:

- **Web Server/Browser:** Used by the Service Platform, as well as other Service Software.
- **Connectivity:** Provides basic connectivity between the scanner and the OnLine Center (OLC) or the field engineer in the field.
- **Configuration:** Provides the interface to configure the various iLinq parameters.
- **Contact GE:** Enables the user to contact the OnLine Center and describe the problems with their scanner in an easy and convenient way, using a one-touch switch.
- **Interactive Application:** Displayed in the form of HTML pages each time the browser starts. This is the entry point for any user to start any iLinq application.

7-5-2 Global Service User Interface

The Global Service User Interface (GSUI) is the pattern for the user interface. This interface standard is followed by all modalities to achieve a common look and feel across all GE Medical Systems products.

The user interfaces provided by the service platform are designed for GE Medical Systems personnel and, as such, are in *English* only. At this time there is no multilingual capacity built into the Common Service Interface.

7-5-2-1 Service Log In

- 1) From the System Configuration window, make sure that **iLinq** (the Common Service platform) is enabled under the *Technical Support* tab, as shown in [Figure 7-58](#) below.

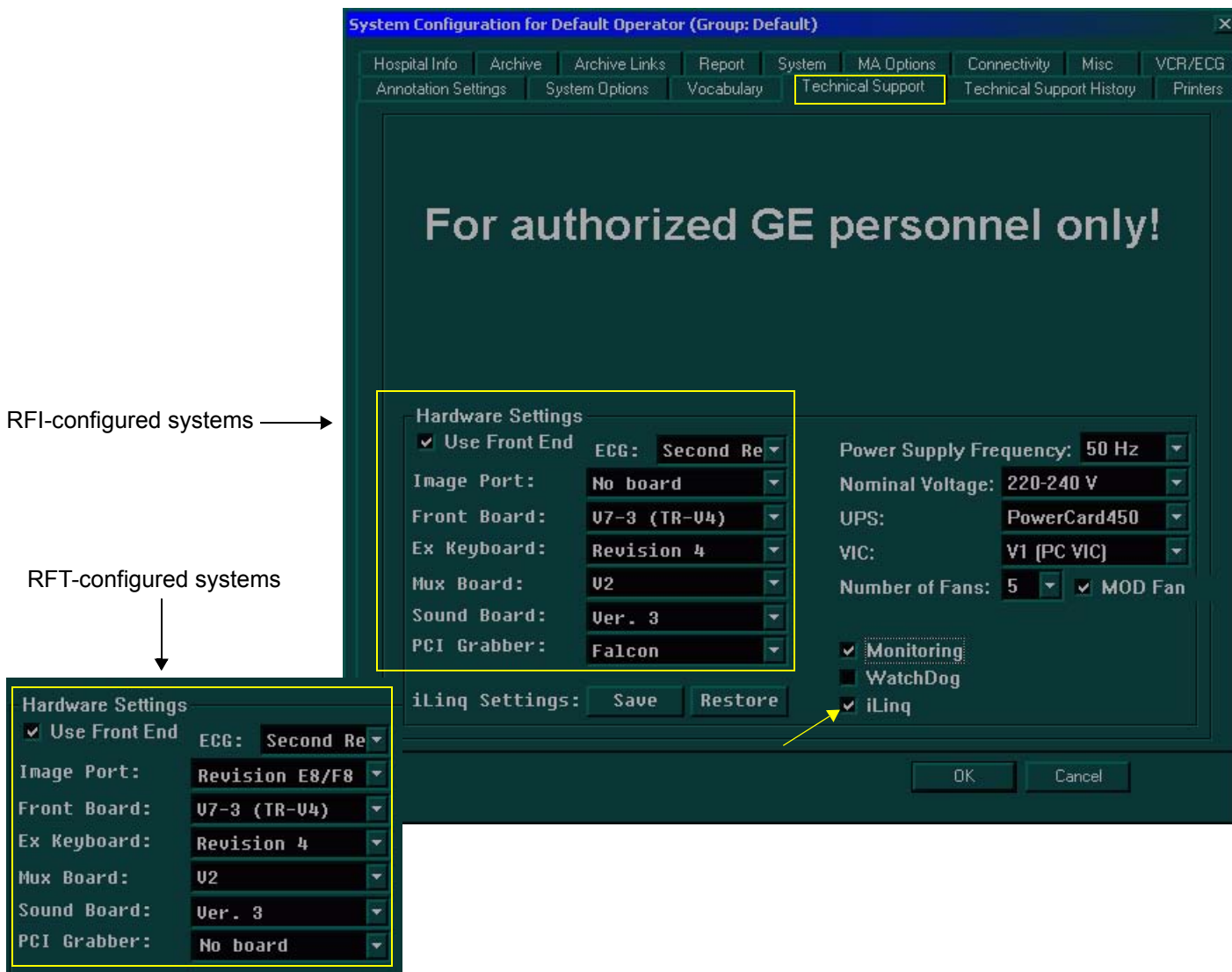



Figure 7-58 Technical Support - System Configuration

- 2) Trackball to **OK** and press **Select**. The System Configuration window closes.

Note: If iLinq was not found to be enabled in [step 1](#), it is necessary to re-boot the system before proceeding.

- 3) Trackball to the wrench icon  in the status bar at the bottom of the scanning screen and press **Select**.

The *Profile Manager* window is displayed, as shown in [Figure 7-59](#) on page 7-86.

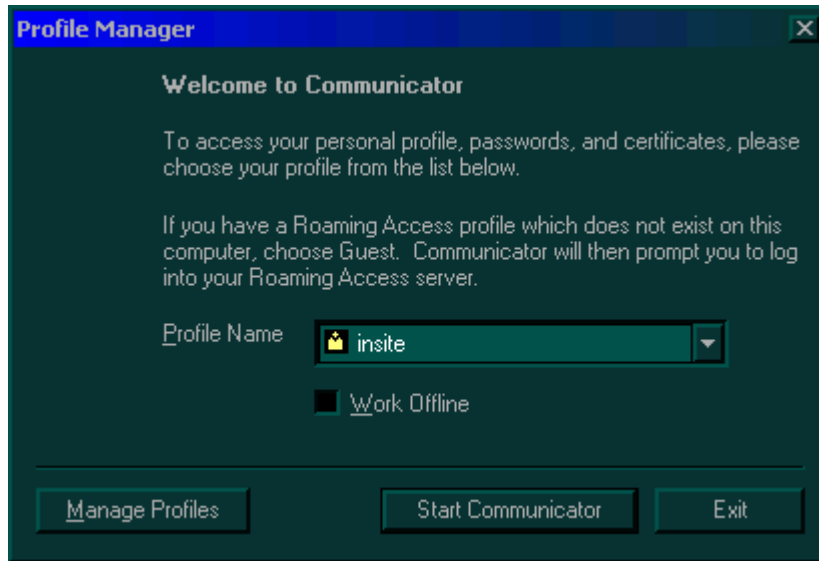

Figure 7-59 Profile Manager Window

- 4) Select **InSite** from the **Profile Name** drop-down list to confirm the connection to the local host
OR
if you are running the application as a field engineer from a remote location, select **Remote** from the **Profile Name** drop-down list.
- 5) Trackball to the **Start Communicator** button and press **Select**. Wait a while, until the *Service Login* dialog box is displayed, as shown below:

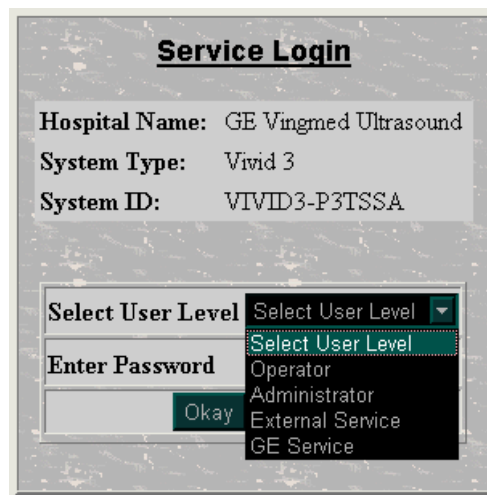

Figure 7-60 Service Login Dialog Box

- 6) Select **Operator** from the **Select User Level** drop-down list, and in the **Enter Password** field, enter the password supplied by the OLC (this is updated on a frequent basis).

Note: For a detailed description of the access and security levels, refer to the [Access and Security](#) section, on page 7-88.

7) Trackball to the **Okay** button and press **Select**. The *GEMS Service Home Page* window is displayed, as shown below:



Figure 7-61 GEMS Service Home Page Window

The *GEMS Service Home Page* window contains details of the system location, the system IP address, the application status and other status information about the system. The navigation bar at the top of the page enables you to select the required tool or application, as described in the following sections:

- [Error Logs Page](#) section, on page 7-88.
- [Diagnostics Page](#) section, on page 7-96.
- [Image Quality Page](#) section, on page 7-109.
- [Calibration Page](#) section, on page 7-109.
- [Configuration Page](#) section, on page 7-110.
- [Utilities Page](#) section, on page 7-111.
- [Replacement Page](#) section, on page 7-125.
- [PM Page](#) section, on page 7-125.

Note: When using the Common Service Desktop, do not iconify any of the *Common Service Desktop* windows, as they will be located in the bottom-left corner of the screen (behind the *Service Desktop Manager* window) and cannot be restored. Resize the windows with the mouse, and move them as required to make room for other windows.

7-5-2-2 Access and Security

The service interface has various different security and user levels. Users are only granted access to the tools they are authorized to use, as described in the following table:

Table 7-1: Access and Security

User Level	Access Authorization
Operator	Normally used in-house and protected with a special scanner configuration that is not allowed to leave the facility.
Administrator	Use the OLC access method provided by iLinq.
External Services	Access is protected with a physical media key (typically a CD-ROM) and a password. The contents of the media key determine the level of access and the period of time for which access is granted.
GE Service	Requires a network connection, a physical media key and knowledge of the password.

All access to the service interface is via the Network port, except for iLinq. A modem on the scanner is specifically intended for iLinq use. Every access request, whether successful or not is logged in a service access log that can be viewed by authorized users.

7-5-3 Error Logs Page

When the *Error Logs* page is selected (as shown in [Figure 7-62](#) below), the log viewing options described in the following sections, are available:

- [Log Viewer](#) section, on page 7-89.
- [Log Browser](#) section, on page 7-93.



Figure 7-62 Error Logs Page

7-5-3-1 Log Viewer

When the **Log Viewer** option is selected in the left pane of the *Error Logs* page, the following five categories are displayed, each of which enable you to view a number of different system logs.

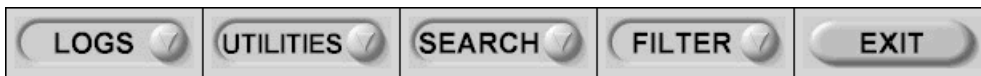

Figure 7-63 Log Viewer Menu Options

The **Log Viewer** is driven by the following high-level requirements:

- Simple filtering of the scanner log(s) with filtering capabilities as a function of login access permissions.
- Log visibility by all services modes.
- Multiple instances of the log viewer.
- Color-coded log entries for severity levels, as follows:
 - Severity 1 - Green
 - Severity 2 - Yellow
 - Severity 3 - Red
- Support the transfer of logs to local or remote destinations.

7-5-3-1-1 Logs

The **Logs** option on the **Logs Viewer** menu enables you to view the following logs:

- **System:** Displays all the system logs, including errors and additional details, as shown below:

TimeStamp	ErrorLevel	Package	ErrorMessage
Sunday, Aug 17 10:06:38, 2003	error	EchoConfig	RELOAD_RESOURCE_FILES - Failed
Sunday, Aug 17 10:06:07, 2003	error	EchoConfig	RELOAD_RESOURCE_FILES - Failed
Sunday, Aug 17 10:04:28, 2003	error	ScCommon.Variant	ScVariant.realCast: Illegal cast Empty: to int
Sunday, Aug 17 10:04:18, 2003	error	ScOption	Option database not loaded
Sunday, Aug 17 10:04:15, 2003	error	Echo2DStrain	Failed to register client paramater
Sunday, Aug 17 10:04:15, 2003	error	Echo2DStrain	Failed to register client paramater
Sunday, Aug 17 10:04:15, 2003	error	Echo2DStrain	Failed to register client paramater
Sunday, Aug 17 10:04:15, 2003	error	Echo2DStrain	Failed to register client paramater

Figure 7-64 System Logs

- **Power:** Displays all the power logs, including errors, monitoring dates and values, as shown below:

LOGS UTILITIES SEARCH FILTER EXIT				
Previous Page		Next Page		Refresh
Page Number: 1				
TimeStamp	ErrorLevel	Package	ErrorMessage	
Sunday, Aug 17 10:05:18, 2003	info	PowMon	-0.552	
Sunday, Aug 17 09:42:21, 2003	info	PowMon	-0.552	
Thursday, Aug 14 20:26:52, 2003	info	PowMon	1.657	
Thursday, Aug 14 19:26:52, 2003	info	PowMon	1.105	
Thursday, Aug 14 18:26:52, 2003	info	PowMon	1.105	
Thursday, Aug 14 17:26:52, 2003	info	PowMon	0.552	
Thursday, Aug 14 16:26:52, 2003	info	PowMon	0.552	
Thursday, Aug 14 15:26:53, 2003	info	PowMon	-0.552	
Thursday, Aug 14 14:53:09, 2003	info	PowMon	0.000	
Thursday, Aug 14 13:57:44, 2003	info	PowMon	0.000	
Thursday, Aug 14 13:53:44, 2003	info	PowMon	-0.552	
Thursday, Aug 14 13:50:59, 2003	info	PowMon	0.000	
Thursday, Aug 14 09:01:33, 2003	info	PowMon	-0.552	
Thursday, Aug 14 08:01:33, 2003	info	PowMon	-0.552	

Figure 7-65 Power Logs

- **Temperature:** Displays all the temperature logs, including errors, monitoring dates and values, as shown below:

LOGS UTILITIES SEARCH FILTER EXIT				
Previous Page		Next Page		Refresh
Page Number: 1				
TimeStamp	ErrorLevel	Package	Upper FEC Sensor	Lower FEC Sensor
Sunday, Aug 17 10:05:18, 2003	info	TempMon	32.0000 °C	40.0000 °C
Sunday, Aug 17 09:42:21, 2003	info	TempMon	32.0000 °C	38.0000 °C
Thursday, Aug 14 20:26:52, 2003	info	TempMon	32.0000 °C	38.0000 °C
Thursday, Aug 14 19:26:52, 2003	info	TempMon	30.0000 °C	38.0000 °C
Thursday, Aug 14 18:26:52, 2003	info	TempMon	30.0000 °C	38.0000 °C
Thursday, Aug 14 17:26:52, 2003	info	TempMon	32.0000 °C	38.0000 °C
Thursday, Aug 14 16:26:52, 2003	info	TempMon	30.0000 °C	38.0000 °C
Thursday, Aug 14 15:26:53, 2003	info	TempMon	30.0000 °C	38.0000 °C
Thursday, Aug 14 14:53:09, 2003	info	TempMon	30.0000 °C	38.0000 °C
Thursday, Aug 14 13:57:44, 2003	info	TempMon	30.0000 °C	38.0000 °C
Thursday, Aug 14 13:53:44, 2003	info	TempMon	30.0000 °C	38.0000 °C

Figure 7-66 Temperature Logs

NOTE: Upper FEC Sensor = sensor inside the Front End
 Lower FEC Sensor = sensor inside the AC Distribution Box

7-5-3-1-2 Utilities

The **Utilities** option on the **Logs Viewer** menu enables you to access the following log utilities:

- **Plot Log:** Enables you to view the results of the Temperature or Power logs in graphical format. Select **Power** or **Temperature** from the **Log** option on the **Logs Viewer** menu, and then select **Plot Log** to display the results as shown below:

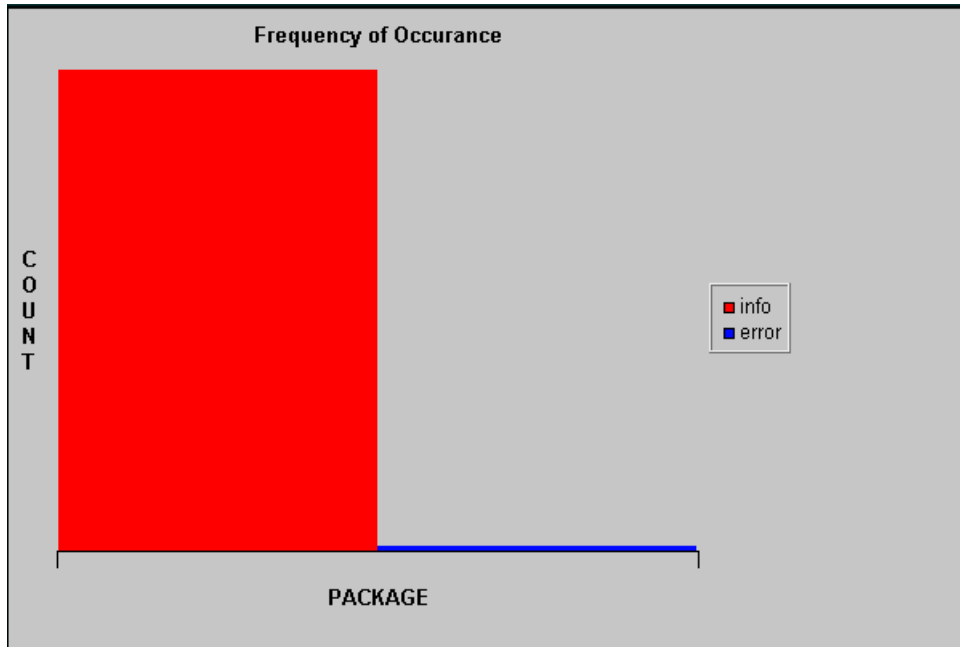

Figure 7-67 Plot Log Window

- **Plot Page:** Enables you to view the results of the System log in graphical format, showing the distribution of the log information according to packages. Select **System** from the **Log** option on the **Logs Viewer** menu, and then select **Plot Page** to display the results as shown below:

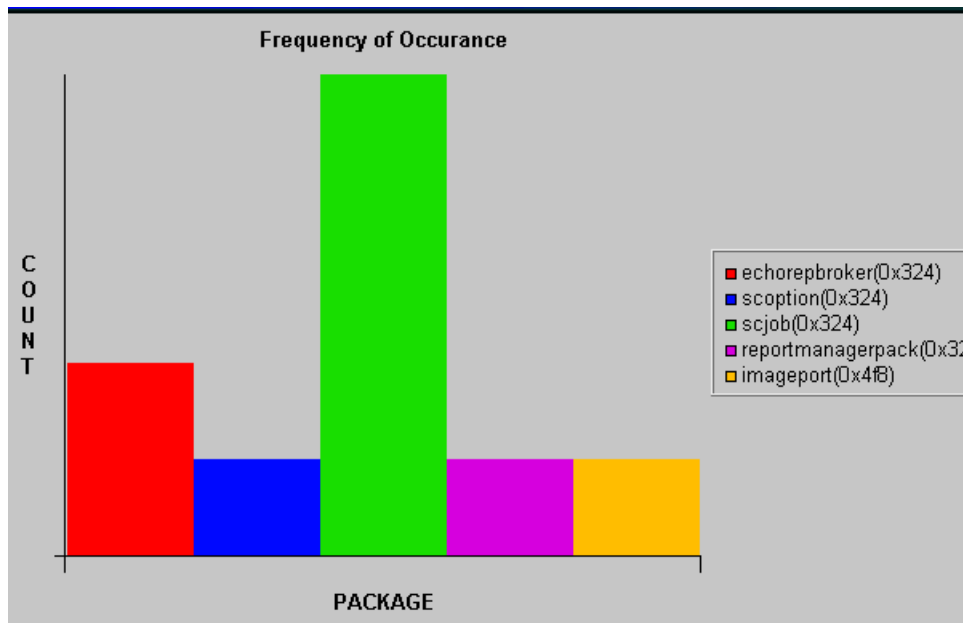

Figure 7-68 Plot Page Window

7-5-3-1-3 Search

The **Search** option on the **Logs Viewer** menu enables you to enter case-sensitive text that you want to filter from the logs or pages that you are currently viewing, as shown below:



Figure 7-69 Search for Text in Log or Page

7-5-3-1-4 Filter

The **Filter** option on the **Logs Viewer** menu is available to users with the GE Service access level. Select the **System Logs** option to select default options that you want to filter from the **System Logs**, as shown below:

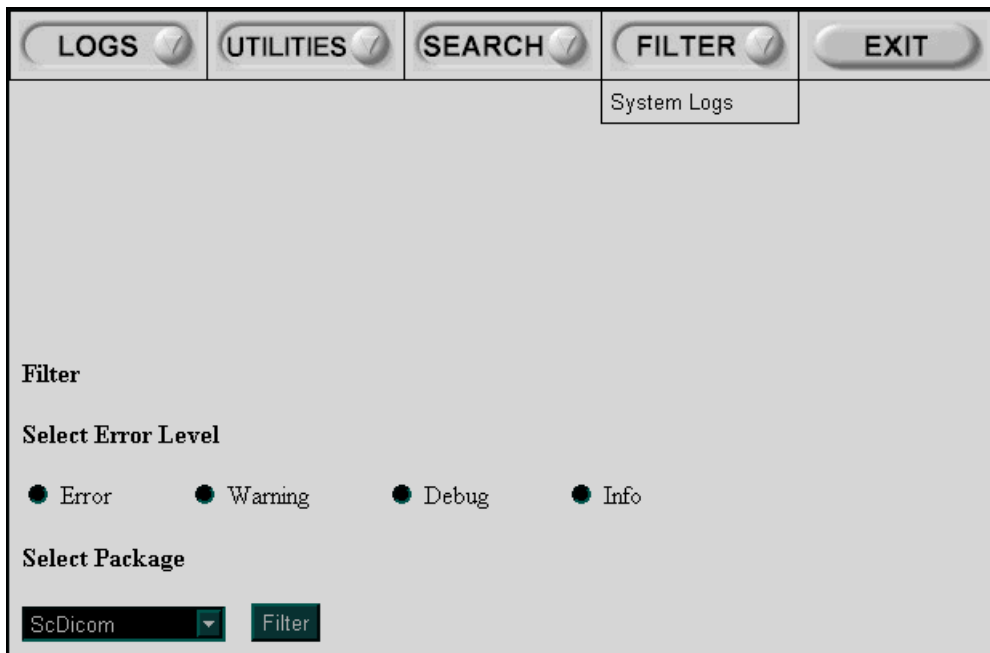

Figure 7-70 Filter Options

7-5-3-1-5 Exit

The **Exit** option on the **Log Viewer** menu enables you to exit the **Log Viewer**. Select the **Exit Log Viewer** option to return to the Common Service Desktop.



Figure 7-71 Exit Option

7-5-3-2 Log Browser

When **Log Browser** is selected in the left pane of the *Error Logs* page, you can browse through the different log categories. All the logs that were generated during the past 3 months are listed under *Logs Available on System*, as shown in [Figure 7-72](#) below:



Figure 7-72 Log Browser

Each system re-boot will generate a new log file; each log file can be viewed by selecting the appropriate link, as shown in the example in [Figure 7-73](#) below:

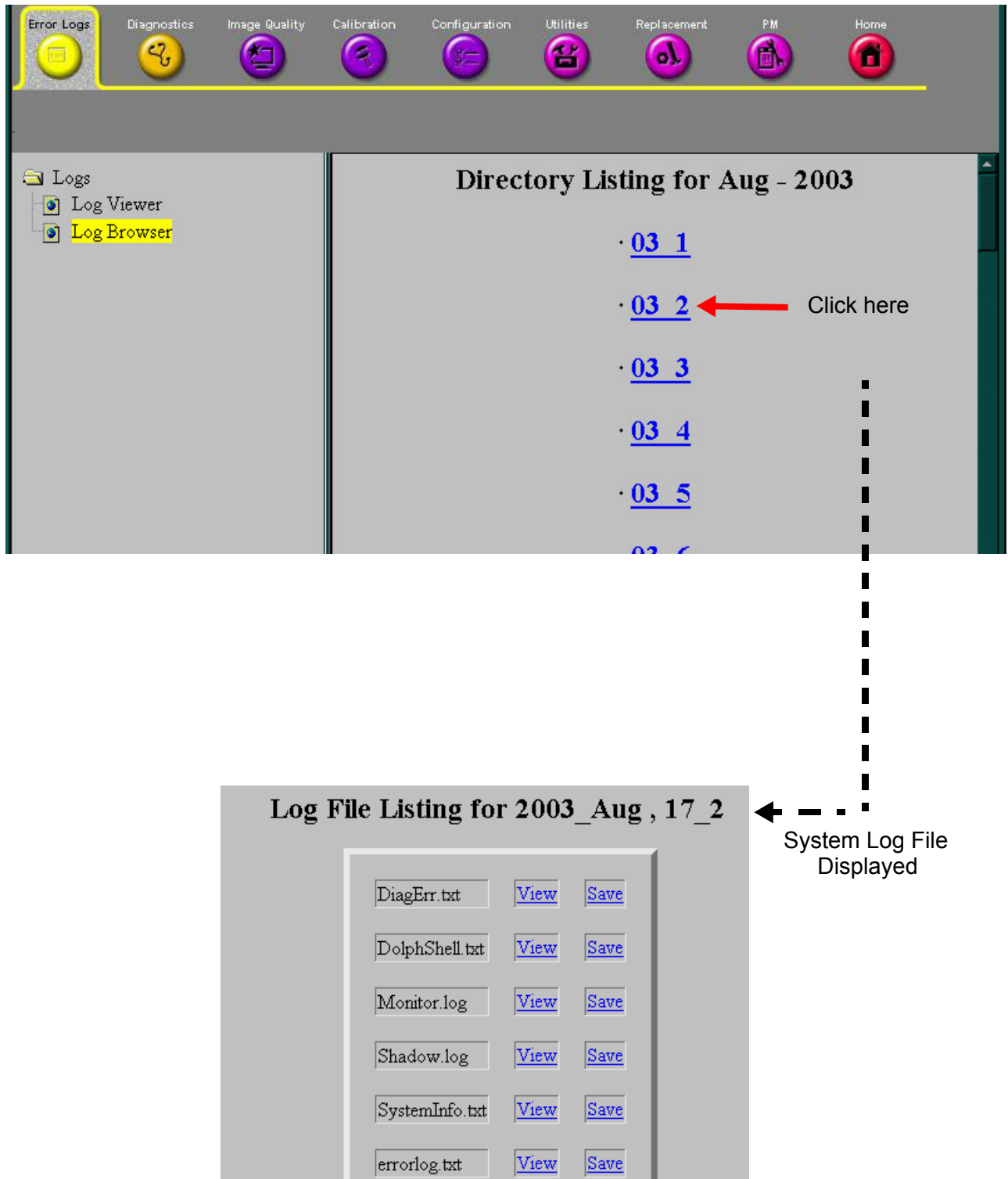

Note: _2 signifies the second reboot of that day

Figure 7-73 Viewing a Log File

If required, a log file can be saved using the **Save** function from this screen ([Figure 7-73](#)) (i.e, when you are connected to the system remotely), or you may save the file to a floppy disk on the system itself.

Only three log files may be reviewed in the field:

- DiagErr
- SystemInfo
- errorlog

For all others, the information contained within the log file would be meaningless since it needs to be reviewed on an actual system and cannot be analyzed remotely.

7-5-4 Diagnostics Page

The service platform uses a web-controlled user interface to provide access to common service components and perform diagnostics. There are two types of diagnostics:

- **Interactive:** The user is required to perform an operation on the ultrasound unit in order for the test to be completed successfully. This option is not applicable when used remotely.
- **Non-Interactive:** The tests are performed without the user's intervention.

When the *Diagnostics* page is selected, as shown below, the options described in the following sections are available:

- [Utilities](#) section, on page 7-97.
- [PC Diagnostics](#) section, on page 7-101.
- [Front End Diagnostics](#) section, on page 7-104.

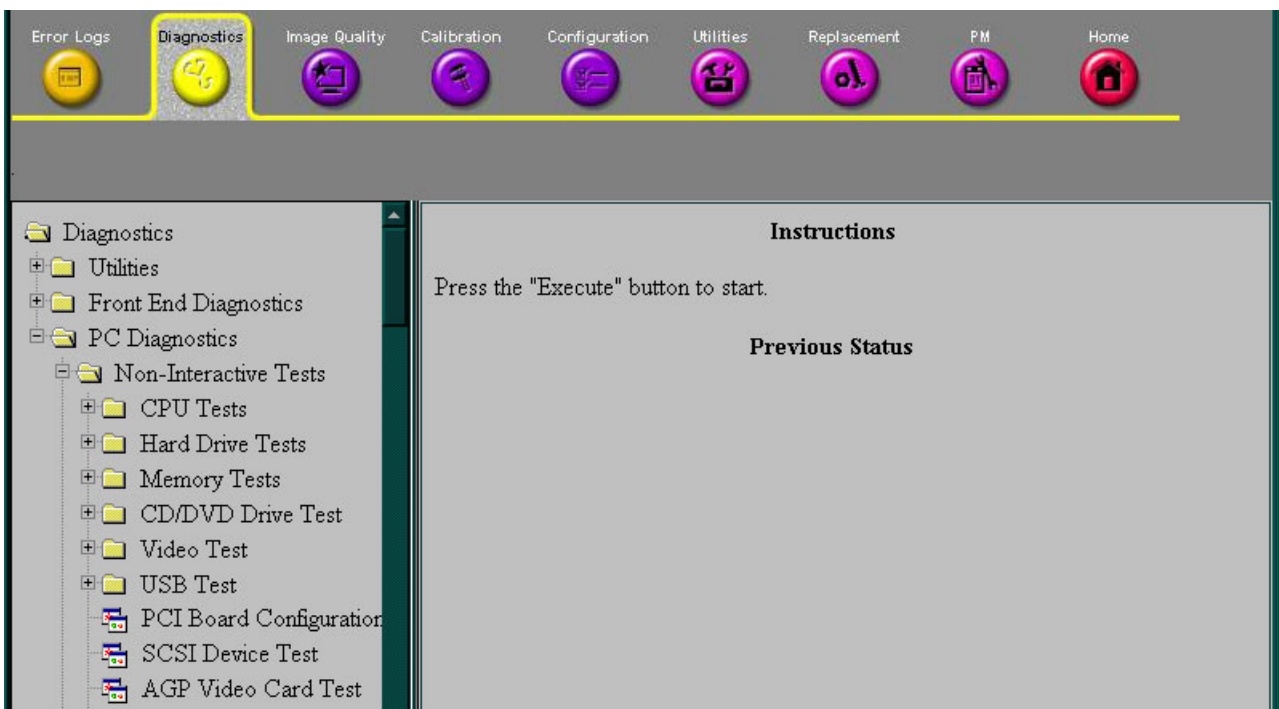

Figure 7-74 Diagnostics Page

7-5-4-1 Diagnostics Page

When a test is selected in the left pane of the *Diagnostics* page, the right pane is divided into three frames, as shown in [Figure 7-74](#) on page 7-96.

7-5-4-1-1 Instructions Frame

The Instructions frame displays a test-specific HTML page, or the default instructions HTML page.

7-5-4-1-2 Status Frame

The Status frame displays the last known status for the particular diagnostic. When a new diagnostic test is performed, the Status frame displays the current status of all test results.

7-5-4-1-3 Control Frame

The Control frame enables you to control the diagnostics and provide feedback. The background color of the Control frame is initially grey. Upon completion of a diagnostic, the background color changes to indicate the completion status - either Red (fail), Green (pass) or Grey (abort).

- **Execute Button:** Enables you to start a selected diagnostic test. Once the diagnostic is running, the Execute button becomes the Abort button, enabling you to stop the diagnostic.
- **Loop Count Field:** Enables you to enter the number of times that the diagnostic test should be performed. Any numeric value between one and four digits can be entered. This field is queried after you press **Execute** to start a diagnostic test.
- **Text Field:** Displays a short starting or aborting message, as well the diagnostic completion status.
- **Progress Indicator:** Displays the test progress.

7-5-4-2 Utilities

When the **Utilities** option is selected in the left pane of the *Diagnostics* page, the following operations can be performed (refer to [Figure 7-75](#)):

- **Disruptive Mode:** Enables you to put the unit into Disruptive Mode, required in order to perform all the Front End diagnostics, as described in the [Front End Diagnostics](#) section, on page 7-104. When this mode is requested by the OLC or by the field engineer, the user will be asked to confirm Disruptive Mode by clicking the **Yes** button, as shown below:

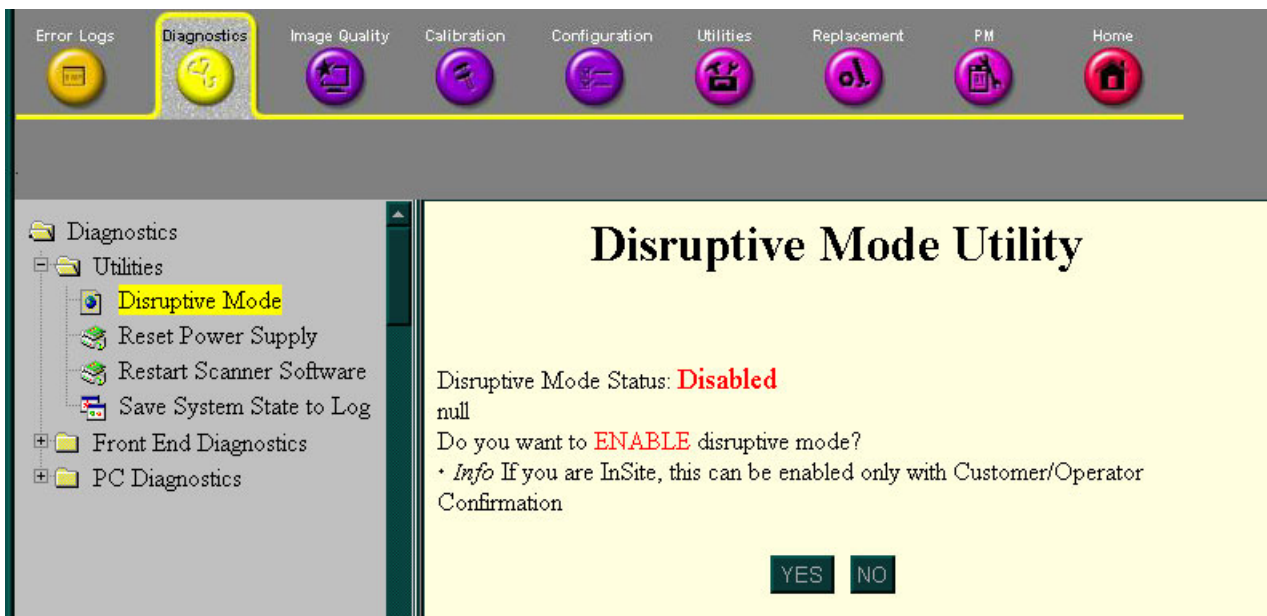

Figure 7-75 Request for Disruptive Mode

- **Reset Power Supply:** Enables you to reset the Front End power supply:

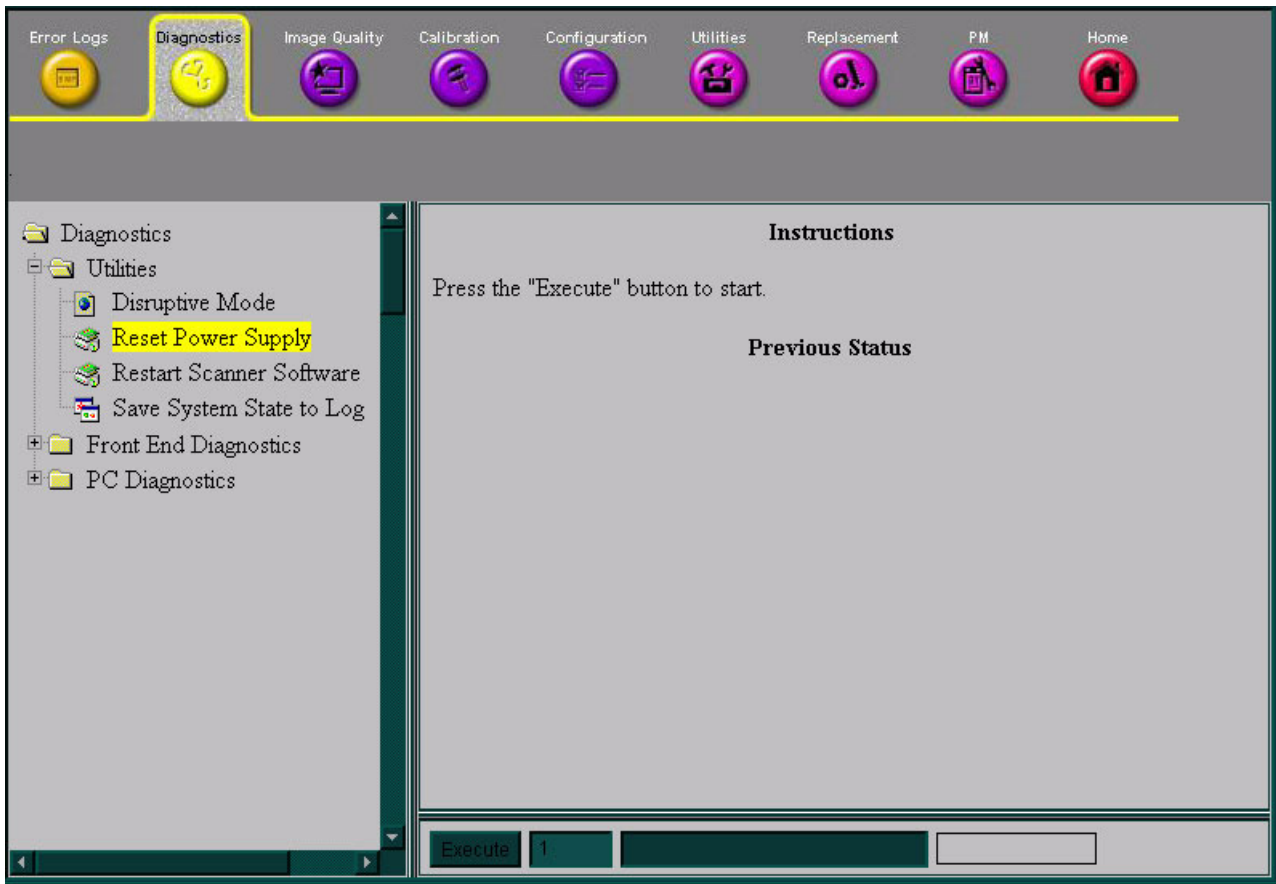

Figure 7-76 Reset Power Supply

- **Restart Scanner Software:** (System Shutdown) Enables you to remotely shutdown or restart the system.

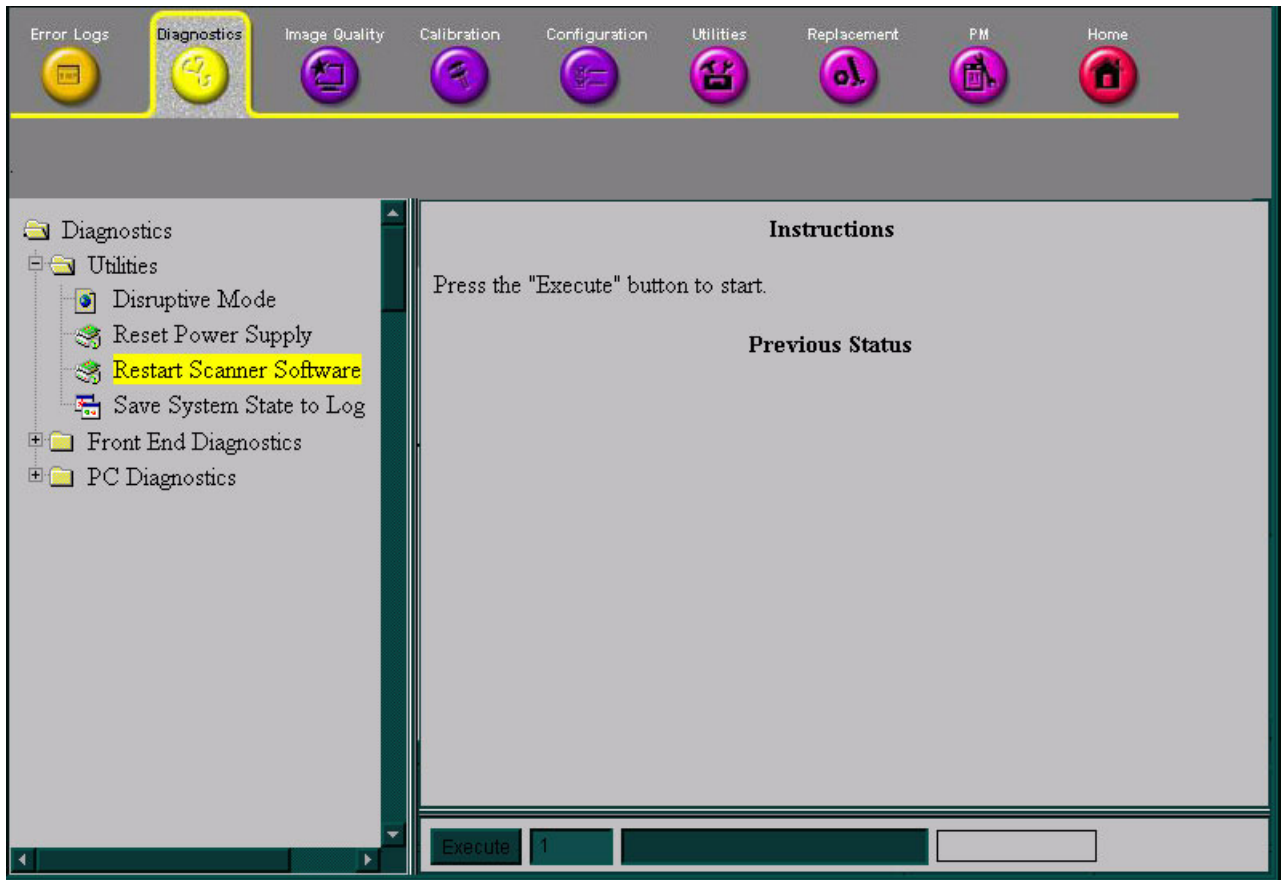

Figure 7-77 Restart Scanner Software

- **Save System State to Log:** This performs the same system operation as that initiated when pressing <Ctrl> F or <Alt> D.

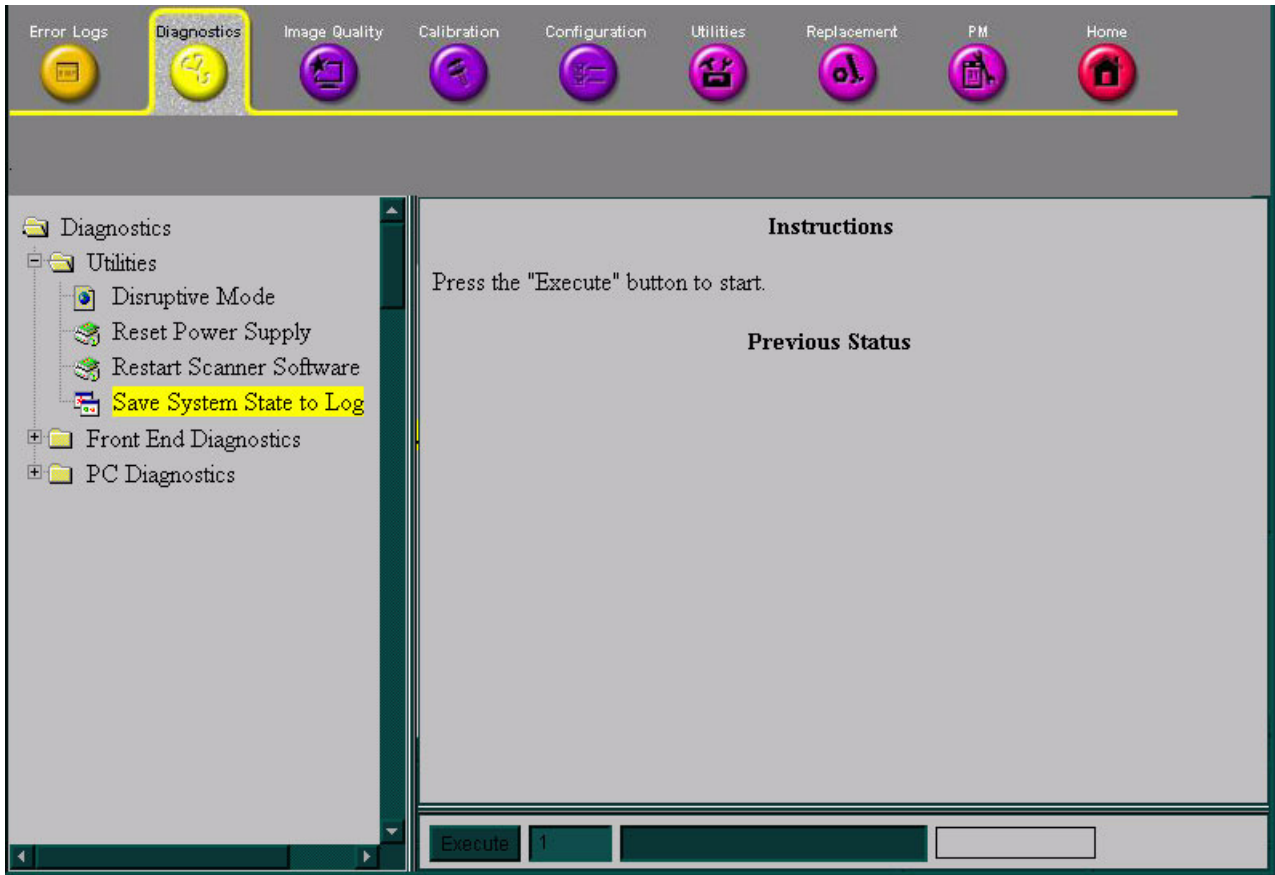

Figure 7-78 Save System State to Log

7-5-4-3 PC Diagnostics

When **PC Diagnostics** is selected in the left pane of the *Diagnostics* page, the diagnostic tests described in the following sections can be performed:

- *CPU Tests* section, below.
- *Hard Drive Tests* section, on page 7-102.
- *Memory Tests* section, on page 7-102.
- *DVD/CD-ROM Drive Tests* section, on page 7-102.
- *Video Test* section, on page 7-103.
- *PCI Board Configuration Test* section, on page 7-103.

NOTE: *The USB Test is also listed under PC Diagnostics, but should not be used.*

7-5-4-3-1 CPU Tests

When **PC Diagnostics** is selected in the left pane of the *Diagnostics* page, the following CPU diagnostic tests can be performed:

- **CPU Test (All):** Performs a battery of tests on your CPU to ensure that it is working properly. All the remaining tests are performed as part of the CPU Test.
- **CPU Registers:** Tests the CPU Registers using the default test patterns. On 32 bit CPUs, the extended registers are also checked. If errors are detected, the failed registers are listed.
- **CPU Arithmetics:** Tests the proper function of the arithmetic commands ADC, ADD, DEC, DIV, IDIV, IMUL, INC, MUL, SBB and SUB with 16 and 32 bit operands. If errors are detected, the failed commands and operands are listed.
- **CPU String Operations:** Tests the proper operation of the string commands LODS, MOVS, SCAS and STOS with 8, 16 and 32 bit operands. If errors are detected, the failed commands and operands are listed.
- **CPU Logical Operations:** Tests the proper operation of the logical operations AND, NOT, OR and XOR with 16 and 32 bit operands. If errors are detected, the failed operands are listed.
- **CPU Math Registers:** Tests the coprocessor register stack, pointers and commands FLDLZ, FLDPI, FLDLN2, FLDLG2M, FLDL2T, FLDL2E and FLD1. If errors are detected, the failed steps and commands are listed.
- **CPU Math Commands:** Tests the coprocessor commands FBLD/FBSTP, FLD/FST, FXCH, FCOM, FICOM, FTST, FXAM and FUCOM. If errors are detected, the failed instructions are listed.
- **CPU Transcendental:** Tests the coprocessor transcendental commands F2XM1, FPATAN, FPTAN, FYL2XP1, FCOS, FSIN and FSINCOS. If errors are detected, the failed commands are listed.
- **CPU MMX Arithmetic:** Tests the MXX commands PADD, PSUB, PMUL and PMADD. If errors are detected, the failed commands are listed.
- **CPU MMX Logical:** Tests the MXX commands PAND, PANDN, POR and PXOR. If errors are detected, the failed commands are listed.
- **CPU MMX Shift:** Tests the MXX commands PSHL and PSRL. If errors are detected, the failed commands are listed.
- **CPU MMX Data Transfer:** Tests the MXX commands MOVD and MOVQ. If errors are detected, the failed commands are listed.
- **CPU MMX Misc.:** Tests the MXX commands PCMPEQ, PCMPGT, PACKSS, PACKUS and PUNPCK. If errors are detected, the failed commands are listed.

7-5-4-3-2 Hard Drive Tests

When **PC Diagnostics** is selected in the left pane of the *Diagnostics* page, the following hard drive diagnostic tests can be performed:

- **Hard Drive Test (All):** Performs a battery of tests to examine the hard drive and ensure that it can perform all its functions. All the remaining tests are performed on the hard drive to ensure that the hard disk controller and the drive mechanism are working correctly. The disk surface itself is also checked. This test may take over ten minutes.
- **Hard Drive Linear Seek:** Moves the hard disk drive heads from track 0 to the maximum track one track at a time.
- **Hard Drive Funnel Seek:** Moves the hard disk drive heads in a funnel fashion (from the first track to the last, then to the second track, the second last track, the third track and so on).
- **Hard Drive Surface Scan:** Scans the surface for defects on the hard disk drive.

7-5-4-3-3 Memory Tests

When **PC Diagnostics** is selected in the left pane of the *Diagnostics* page, the following memory diagnostic tests can be performed:

- **Memory Test (All):** Uses 18 test patterns to test memory locations. If errors are detected, the address of the block in which the error was detected is shown. During testing, these diagnostics will also look for parity errors and other exceptions. If encountered, these are added to the test log as errors.
- **Memory Pattern Test:** Uses several test patterns to test as much memory as possible.
- **Memory Parity Test:** Checks for parity errors on the memory bus during intensive string transfer operation. If an error is detected, the address of the failed block is displayed.

7-5-4-3-4 DVD/CD-ROM Drive Tests

When **PC Diagnostics** is selected in the left pane of the *Diagnostics* page, the following DVD/CD-ROM diagnostic tests can be performed. **Seek** tests ensure that the drive can access all locations on a disk, while **Read** tests ensure that the drive can read all the data.

- **DVD/CD-ROM Test (All):** Examines the DVD or CD-ROM drive to ensure that it is working properly. You can use either a data CD-ROM disk or a DVD disk for these tests, You cannot use an audio CD for this test.
- **DVD/CD-ROM Linear Seek:** Tests that all the locations on a DVD or CD-ROM disk can be accessed in a linear fashion, from the first to the last.
- **DVD/CD-ROM Random Seek:** Tests that all the locations on a DVD or CD-ROM disk can be accessed randomly.
- **DVD/CD-ROM Funnel Seek:** Tests that all the locations on a DVD or CD-ROM disk can be accessed in a funnel fashion, from the first to the last, then from the second to the second last, and so on.
- **DVD/CD-ROM Linear Read:** Reads the data on the DVD or CD-ROM disk in a linear fashion, from the beginning to the end.
- **DVD/CD-ROM Random Read:** Reads the data on the DVD or CD-ROM disk randomly.

7-5-4-3-5 Video Test

When **PC Diagnostics** is selected in the left pane of the *Diagnostics* page, the following video diagnostic tests can be performed. These tests use 18 test patterns to fill the video buffer, testing your graphics acceleration and text output

- **Video Test (All):** Test the system's video capabilities. This involves testing the memory, testing the graphics acceleration and testing the text output. You can follow the tests being performed on the monitor. This test can be cancelled at any time by pressing **<Esc>** on the keyboard.
- **Video Memory:** Tests the video memory by filling the video buffer with 18 test patterns, one pattern at a time. These tests fill the entire screen with a single color.
- **Video Data Transfer:** Tests the graphics acceleration part of the video controller. This test fills the screen with black and white concentric squares, and rectangles of various sizes and colors. If errors are detected, the locations of the problems are displayed.
- **Video Text Output:** Prints a text string in random sizes and colors to test the video device driver and video controller.

7-5-4-3-6 Frame Grabber Test

Testing for proper operation of the Frame Grabber Board is achieved by performing the Video Grabbing Test. For details, refer to the [Video Grabbing Test](#) on page 4 - 4. For information regarding the video grabbing calibration procedure, refer to [Video Grabbing Calibration](#) on page 6 - 17.

7-5-4-3-7 PCI Board Configuration Test

A Peripheral Component Interconnect (PCI) bus is a fast standard bus that is common in Pentium systems. When **PC Diagnostics** is selected in the left pane of the *Diagnostics* page, PCI diagnostic tests can be performed to ensure that the PCI bus is working up to speed. The motherboard is scanned to verify the configuration space and to ensure that the diagnostics can communicate with the board.

7-5-4-3-8 Keyboard Test

When **PC Diagnostics** is selected in the left pane of the *Diagnostics* page, the keyboard diagnostic tests can be performed. After selecting your keyboard type from the drop down list, click the **Test** button. The *PCDR Keyboard Test* window is displayed, showing all the keyboard keys. Press each key on the keyboard once and ensure that the corresponding keys on-screen are removed from view. If a key is not removed, that key may be damaged and need to be replaced or repaired. Click the **Reset Keys** button to reset the keyboard, or click the **Close** button to exit the test.

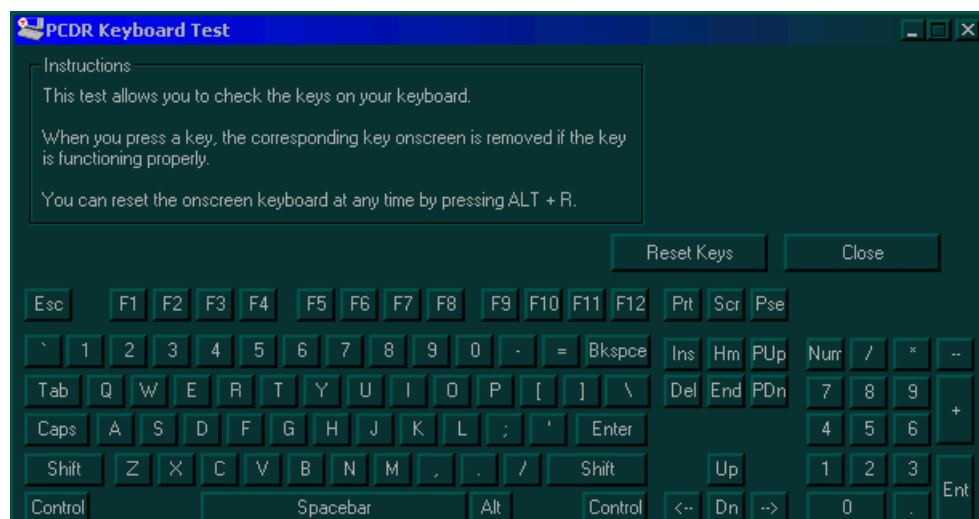

Figure 7-79 PCDR Keyboard Test Window

7-5-4-3-9 Audio Test

The audio test option is not enabled.

7-5-4-3-10 Monitor Test

When **PC Diagnostics** is selected in the left pane of the *Diagnostics* page, the following monitor diagnostic tests can be performed, as shown below:

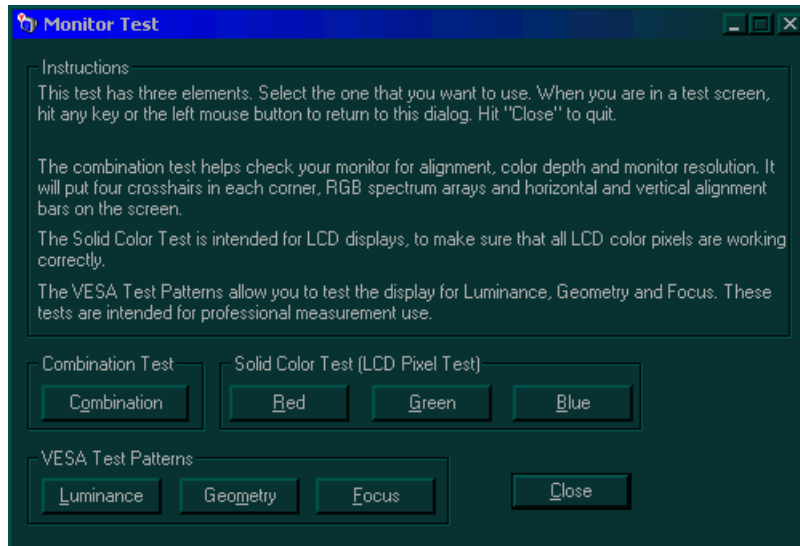

Figure 7-80 Monitor Test

- **Combination Test:** Checks the monitor alignment, color depth and monitor resolution. Four cross hairs are placed in each corner of the screen, as well as RGB spectrum arrays and horizontal and vertical alignment bars.
- **Solid Color Test:** Tests the panel display on laptops and LCD screens. This test display a solid color on the screen to ensure that all the color pixels are operating correctly.
- **VESA (Video Electronics Standards Association) Test Patterns:** Checks luminance, geometry and focus. These tests are designed for professional measurement use.

7-5-4-4 Front End Diagnostics

When the **Front End Diagnostics** option is selected in the left pane of the *Diagnostics* page, the same tests as those performed by pressing **<Ctrl+F11>** during regular operation, can be conducted. Both *Non-interactive* (see [Figure 7-81](#) [or [Figure 7-82](#)]) and *Interactive* (see [Figure 7-83](#)) tests may be performed. However, the *Interactive* tests require the use of specific probes.

NOTE: *To avoid failure alarms during the Front End diagnostics tests, disconnect all probes that are not required to perform the test.*

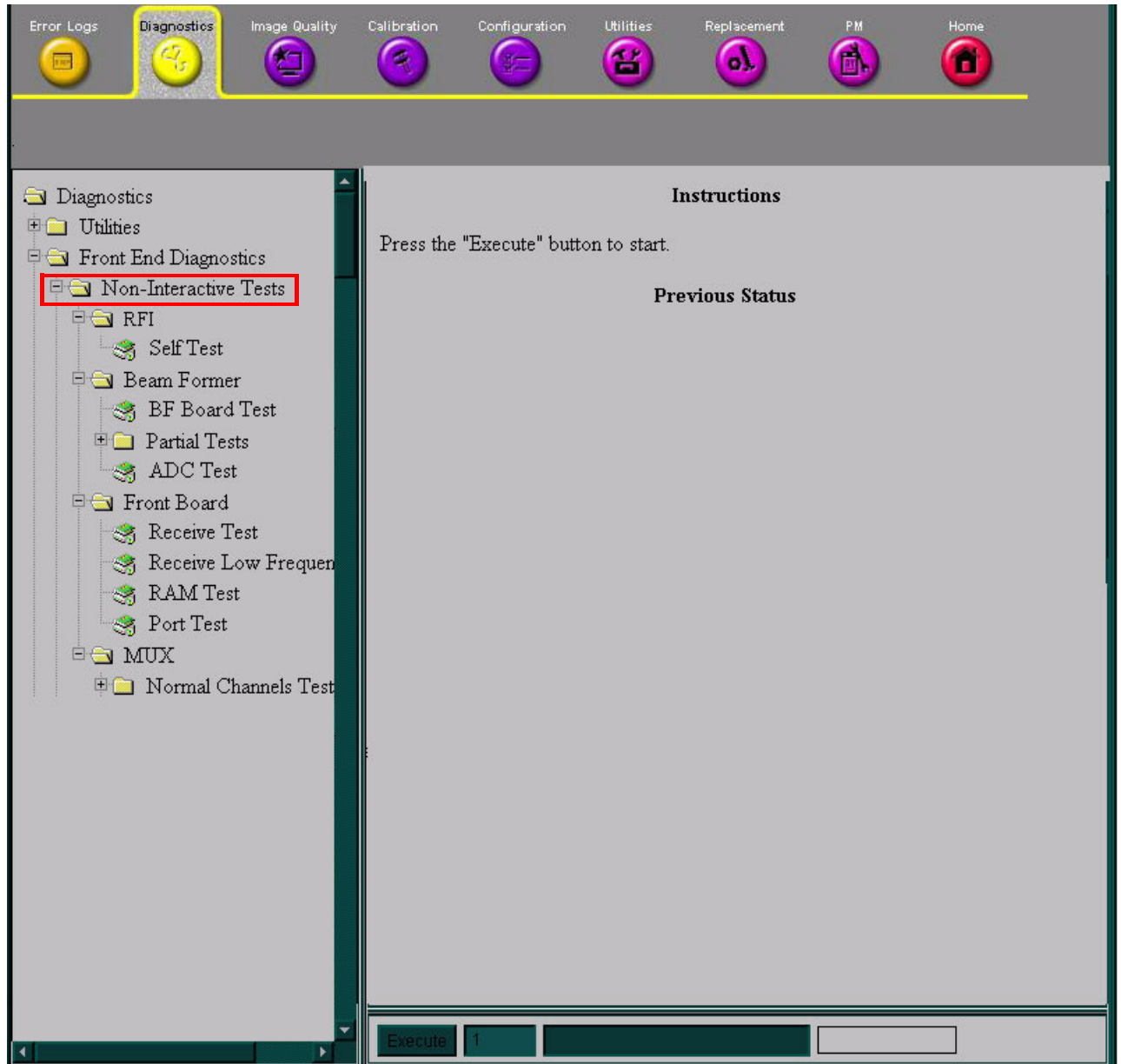

Figure 7-81 Non-Interactive Tests (Systems with RFI Configuration)

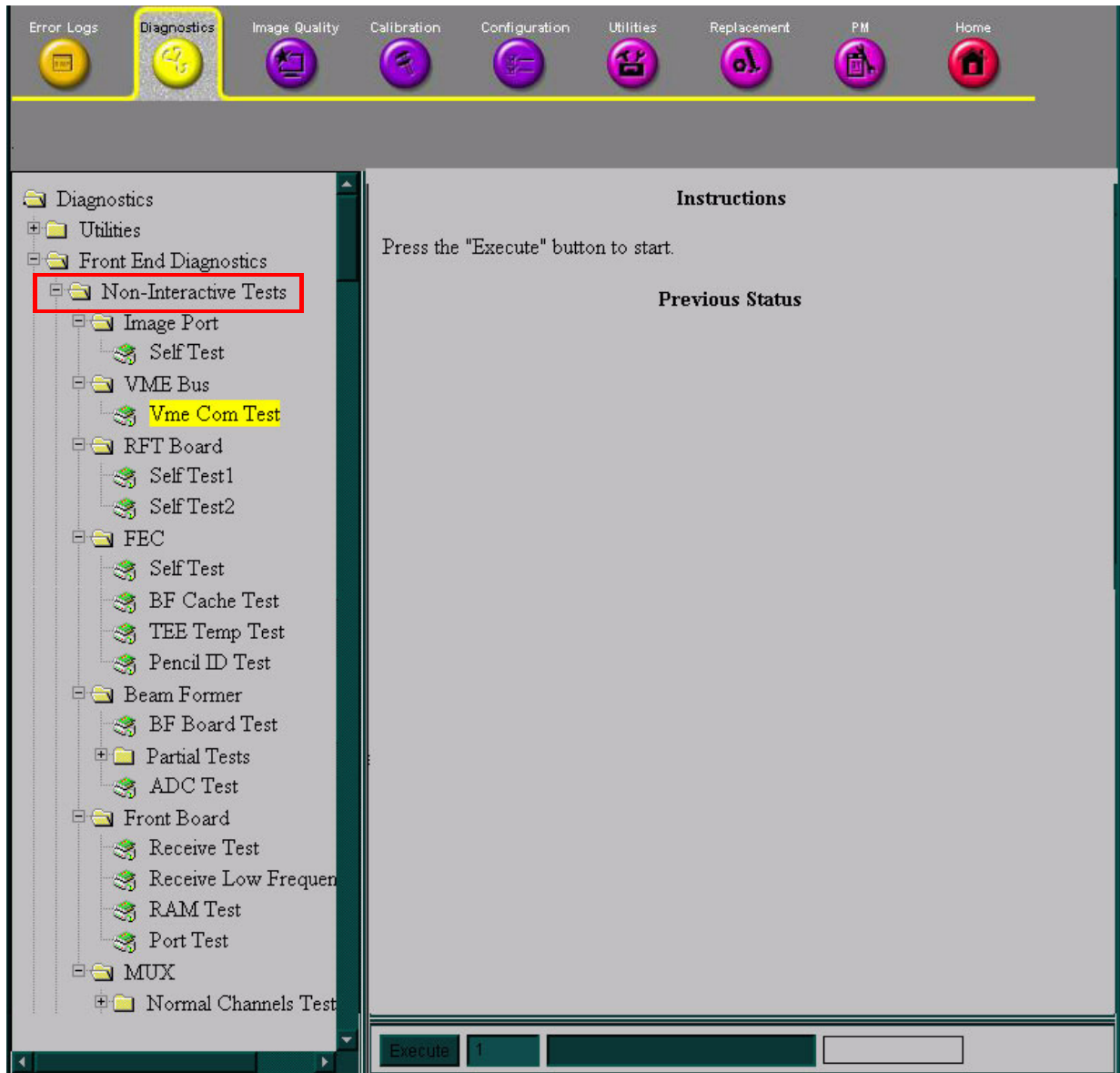

Figure 7-82 Non-Interactive Tests (Systems with RFT Configuration)

For information on performing a specific Non-interactive test, refer to the appropriate section, as follows:

- RFI - see [Radio Frequency Interface \(RFI\) Diagnostic Tests \(for RFI Configuration\)](#) on page 7 - 11
- OR (for systems with RFT Configuration):
 - Image Port - [Image Port \(IMP\) Diagnostic Tests \(for RFT Configuration\)](#) on page 7 - 13.
 - VME Bus - [VME Bus \(VME\) Diagnostic Tests \(for RFT Configuration\)](#) on page 7 - 15.
 - RFT Board - [RFT Diagnostic Tests \(for RFT Configuration\)](#) on page 7 - 17.
 - FEC - [Front End Controller \(FEC\) Diagnostic Tests \(for RFT Configuration\)](#) on page 7 - 19.
- Beam Former - see [Beamformer \(BF\) Diagnostic Tests](#) on page 7 - 21.
- Front Board - see [Front Board Assembly \(FB\) Diagnostic Tests](#) on page 7 - 25.
- MUX - see [MUX Diagnostic Tests](#) on page 7 - 47.

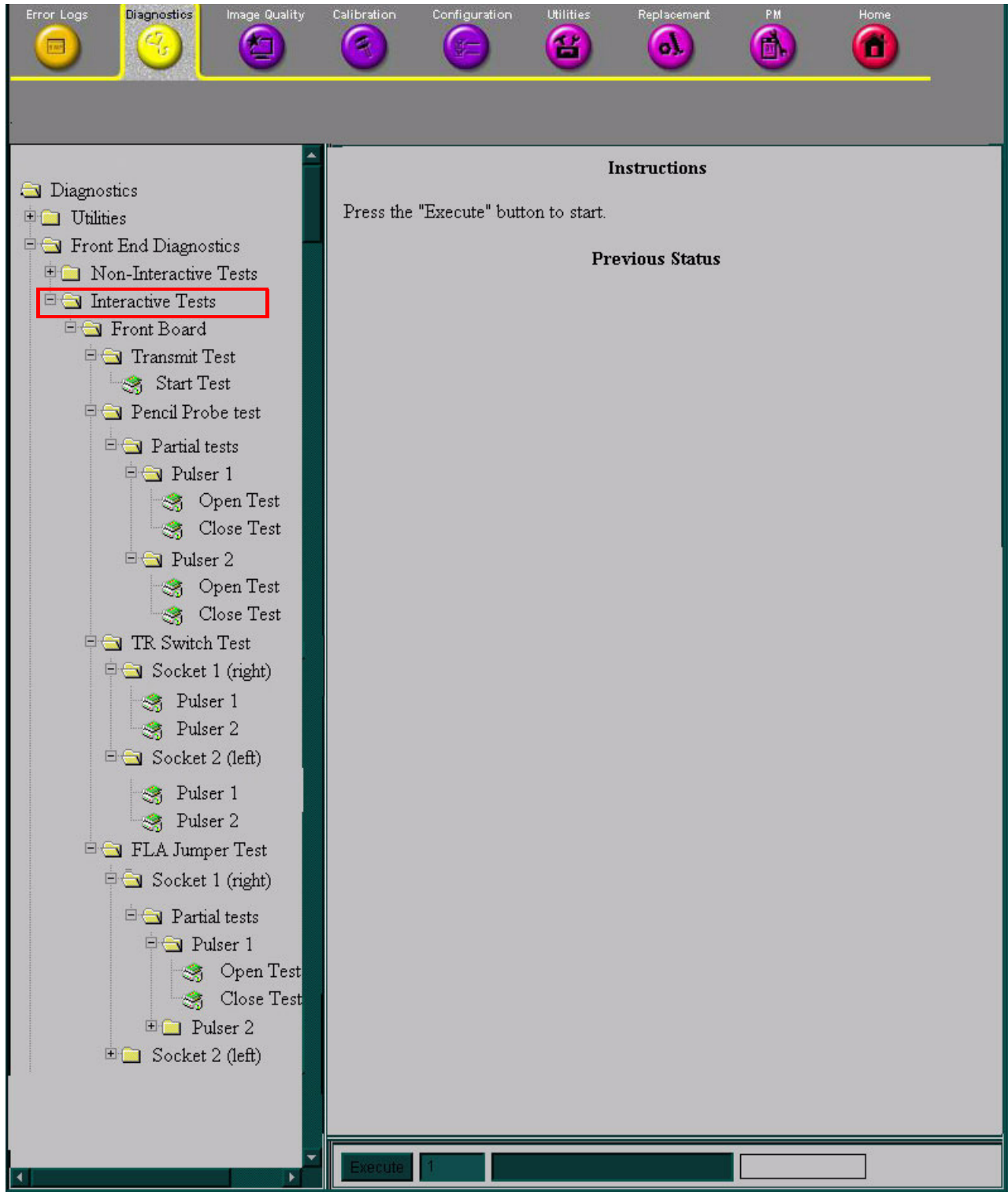

Figure 7-83 Interactive Tests

NOTE: Interactive tests are performed on the Front Board only.

For information on performing a specific Interactive test, refer to the appropriate section, as follows:

- Transmit Test - see [Transmit Test](#) on page 7 - 28.
- FLA Jumper Test - see [FLA Jumper Switch](#) on page 7 - 30
- TR Switch Test - see [TR Switch Test](#) on page 7 - 38.

Note: On the TR Switch Test, *Socket 1* and *Socket 2* relate to which socket the probe is plugged into. Select the appropriate Pulser.

- Pencil Probe Test - see [Pencil Probe Test](#) on page 7 - 40.

7-5-5 Image Quality Page

When the *Image Quality* page is selected, as shown below, you can verify and calibrate image quality.

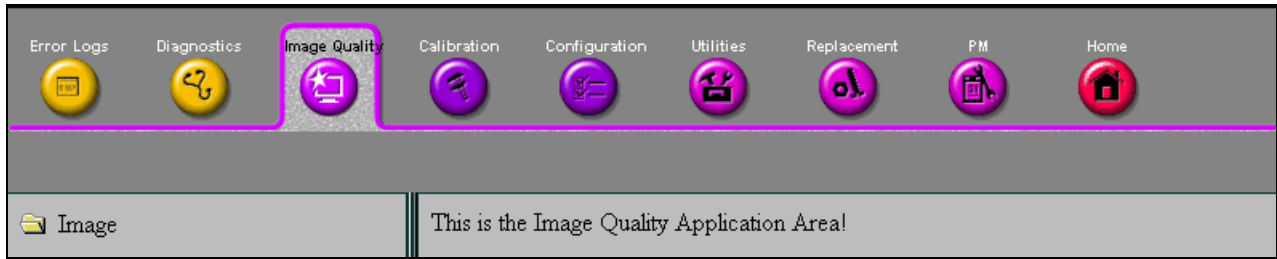

Figure 7-84 Image Quality Page

Note: This page is not populated in this version.

7-5-6 Calibration Page

When the *Calibration* page is selected, as shown below, you can perform different calibration procedures, as described in *Chapter 6, Service Adjustments*.

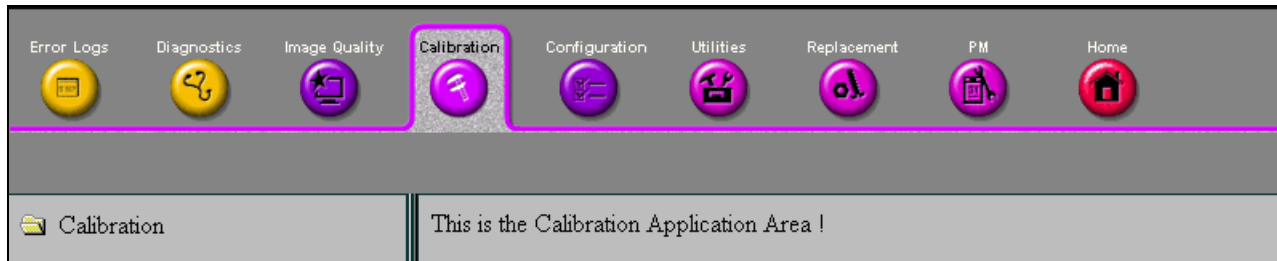

Figure 7-85 Calibration Page

Note: This page is not populated in this version.

7-5-7 Configuration Page

When the *Configuration* page is selected, you can configure the GSUI (InSite). No changes should be made in this page without the help of GE Medical Systems Service Personnel, as any modifications made by untrained personnel can cause damage to the ultrasound unit.

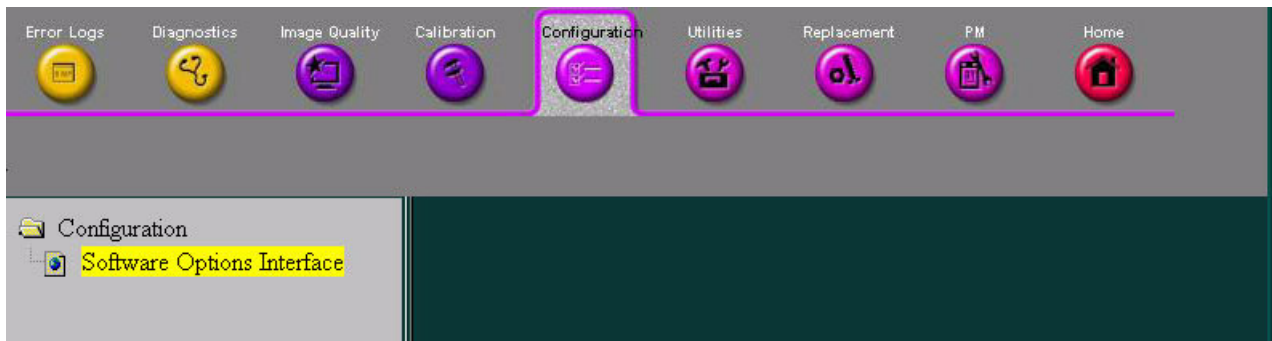

Figure 7-86 Configuration Page

Note: This page is not populated in this version.

7-5-8 Utilities Page

When the *Utilities* page is selected (as shown below), a variety of Windows 2000 utility tools are available to indicate the status of the system, in addition to various other tools.

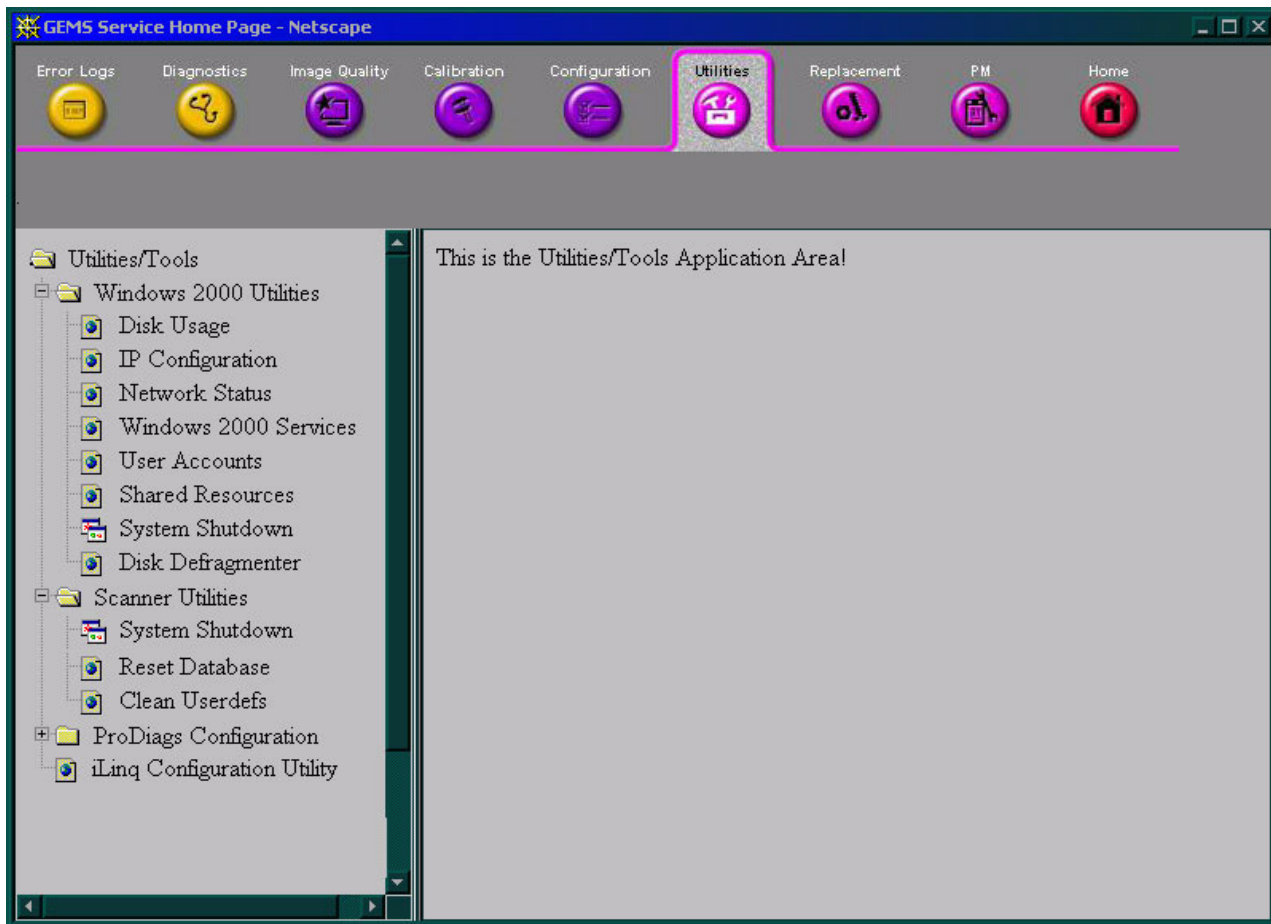

Figure 7-87 Utilities Page

7-5-8-1 Windows 2000 Utility

The information accessed under *Windows 2000 Utilities* are:

- **Disk Usage** - shows the amount of hard disk space available, and the size already utilized.
- **IP Configuration** - shows the IP configuration of the different remote devices - such as, the network or the modem.
- **Network Status** - shows the communication status of active connections on the network.
- **Windows 2000 Services** - shows which services (applications) are currently active on Windows 2000.
- **User Accounts** - shows the internal account information that was provided and set up on the system by the OLC.
- **Shared Resources** - indicates the resources being shared by the system.
- **System Shutdown** - There are three options provided (see [Figure 7-88](#)):
 - Restart System - restart the application
 - Shutdown System - total shutdown of the system
 - Retain Disruptive Mode- request to perform diagnostics remotely

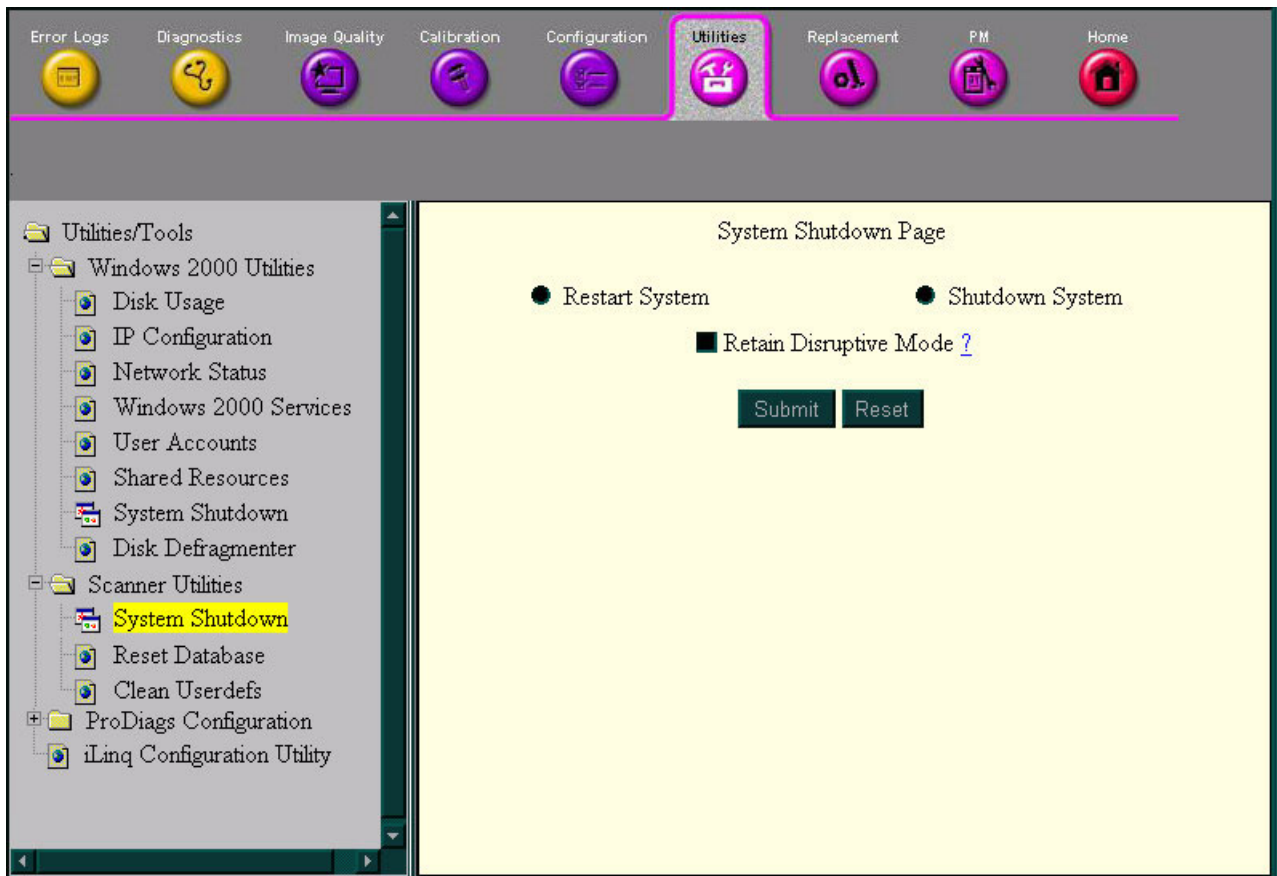

Figure 7-88 System Shutdown

7-5-8-2 Scanner Utilities

The functions accessed under *Scanner Utilities* are described below.

- **System Shutdown** - There are three options provided (described on previous page - also see [Figure 7-88](#))
- **Reset Database** - used to empty the database and reset a new one (see [Figure 7-89](#) below).

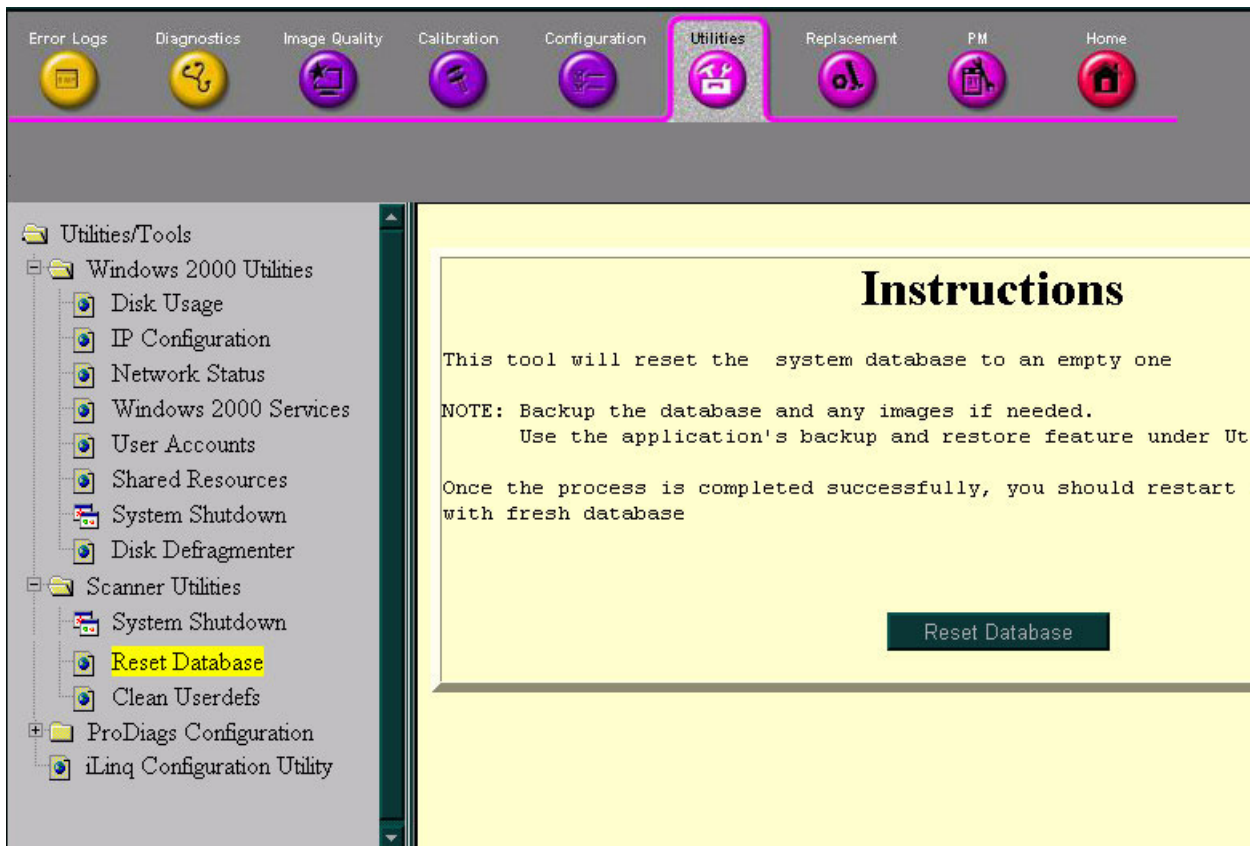
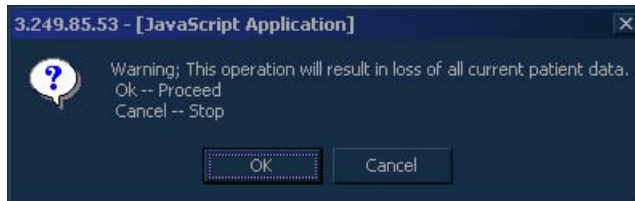

Figure 7-89 Reset Database



WARNING: THIS PROCESS IS IRREVERSIBLE! Before proceeding, make sure you have a complete backup of the existing database.

When selecting **Reset Database**, the following warning message is displayed:



Click **OK** to proceed.

- **Clean UserDefs** - used to clean all user-defined settings and restore the default settings

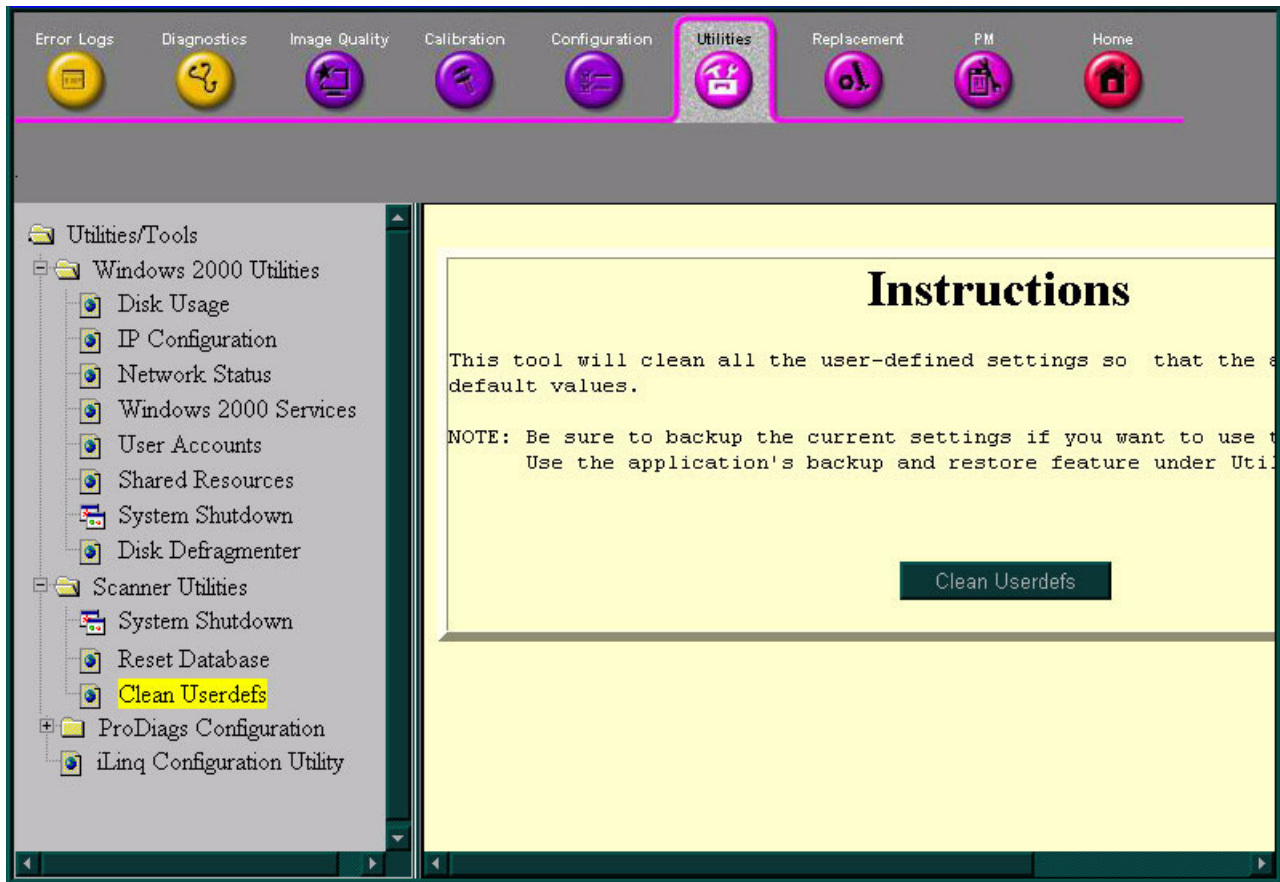
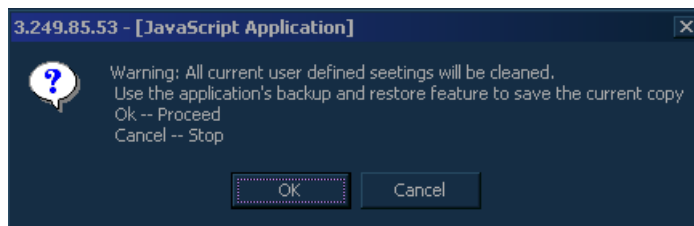

Figure 7-90 Clear User-defined Settings



CAUTION: THIS PROCESS IS IRREVERSIBLE! Before proceeding, make sure you have a complete backup of the current settings if they will be required in the future.

When selecting **Clean Userdefs**, the following warning message is displayed:



After making a back-up copy of the current settings, click **OK** to proceed.

NOTE: This function performs the same procedure as that of Restore Factory Presets (accessed under the System Configuration window - System tab).

7-5-8-3 ProDiags Configuration

7-5-8-3-1 ProDiags Browser

- 1) Select the **Prodiags Browser** under the **Configuration Utility** option. The following message is displayed.

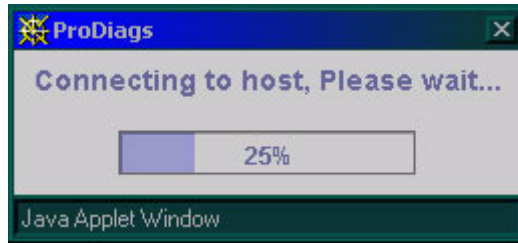

Wait a few minutes, until the following screen is displayed.

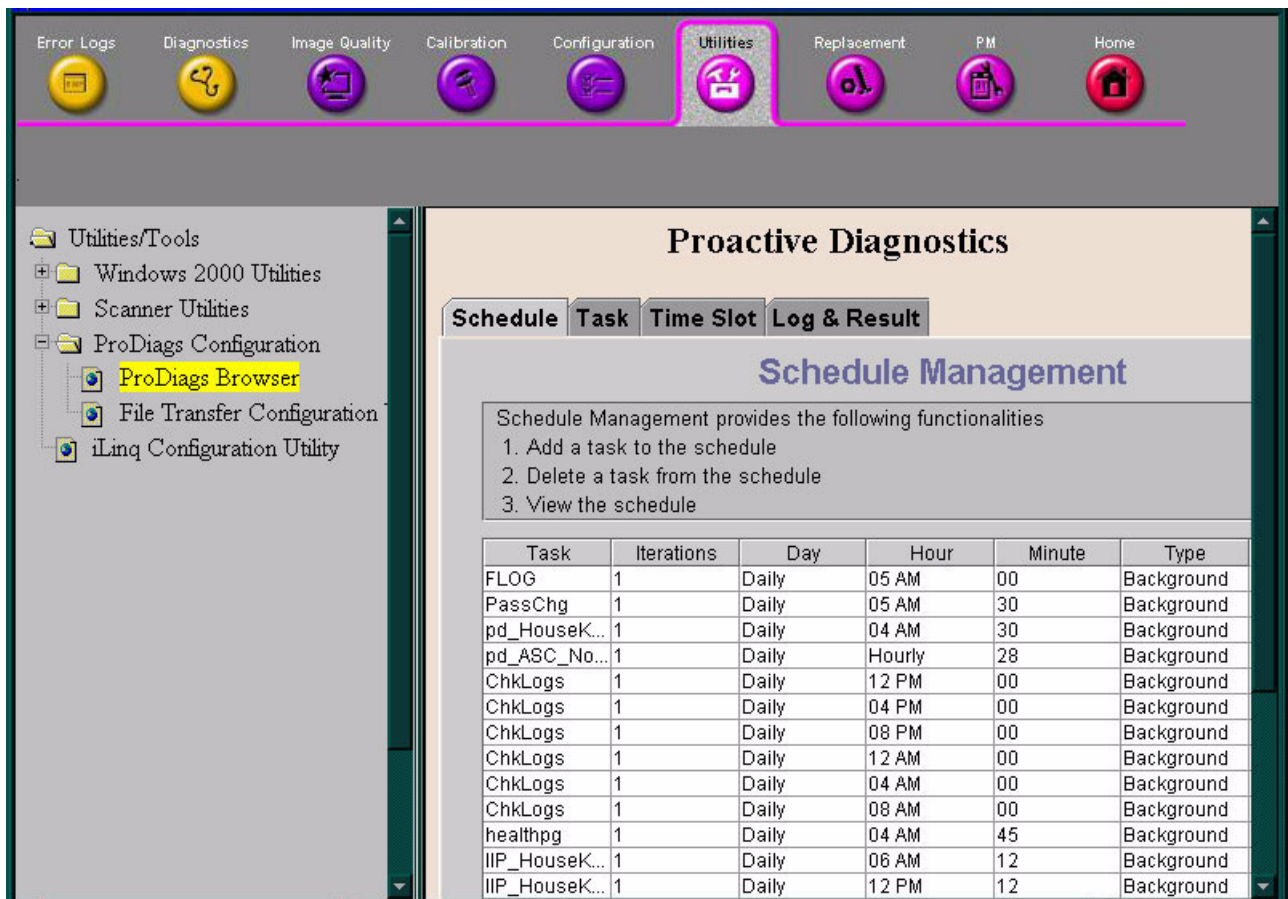

Figure 7-91 ProDiags Browser - Schedule

The **Schedule** tab indicates the tasks that are scheduled, and on which date they are scheduled, and their frequency. It also indicates the type of operation - *Background* or *Foreground*.

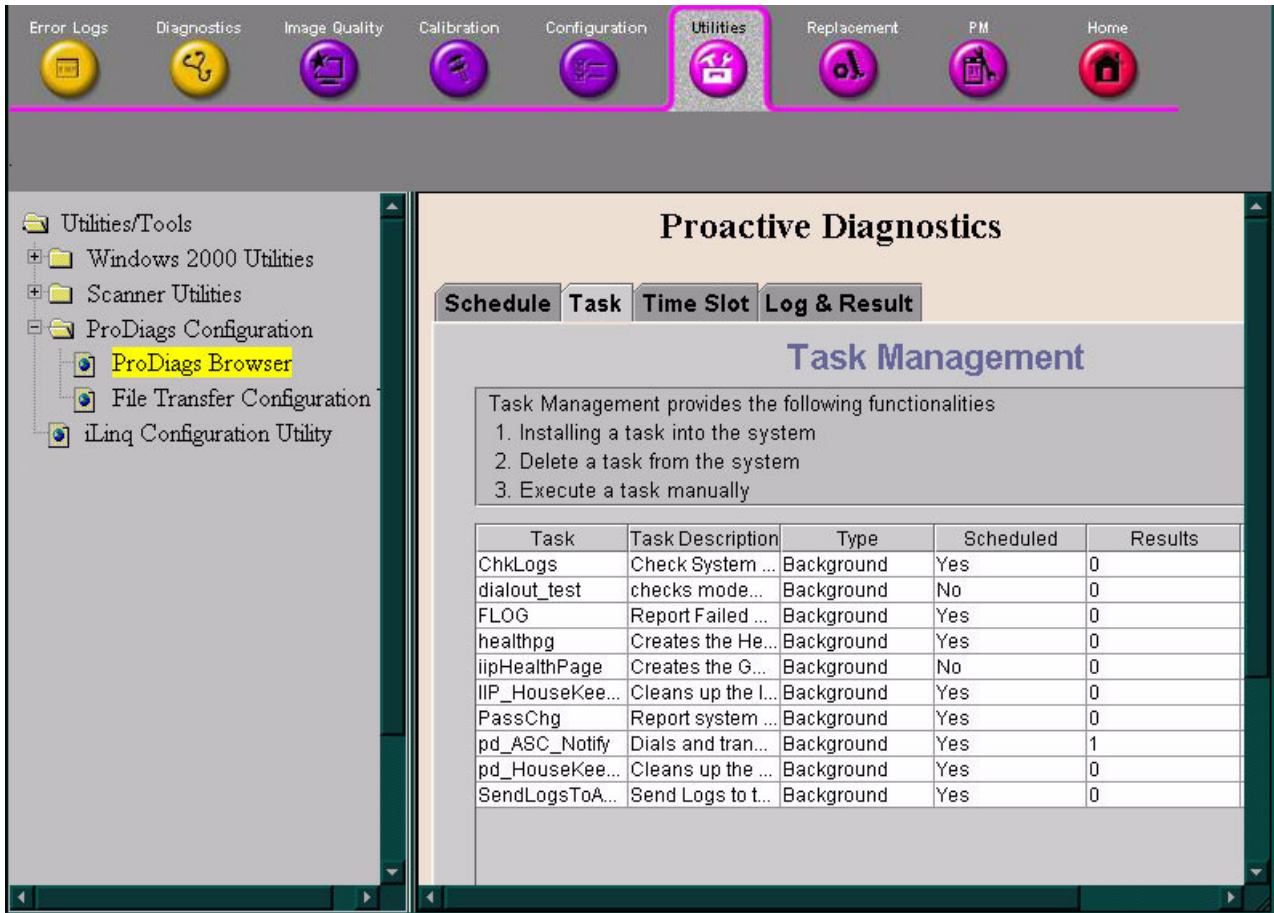

Figure 7-92 ProDiags Browser - Task

The **Task** tab indicates all the tasks that are available for activation. This also indicates which tasks are scheduled, and their type.

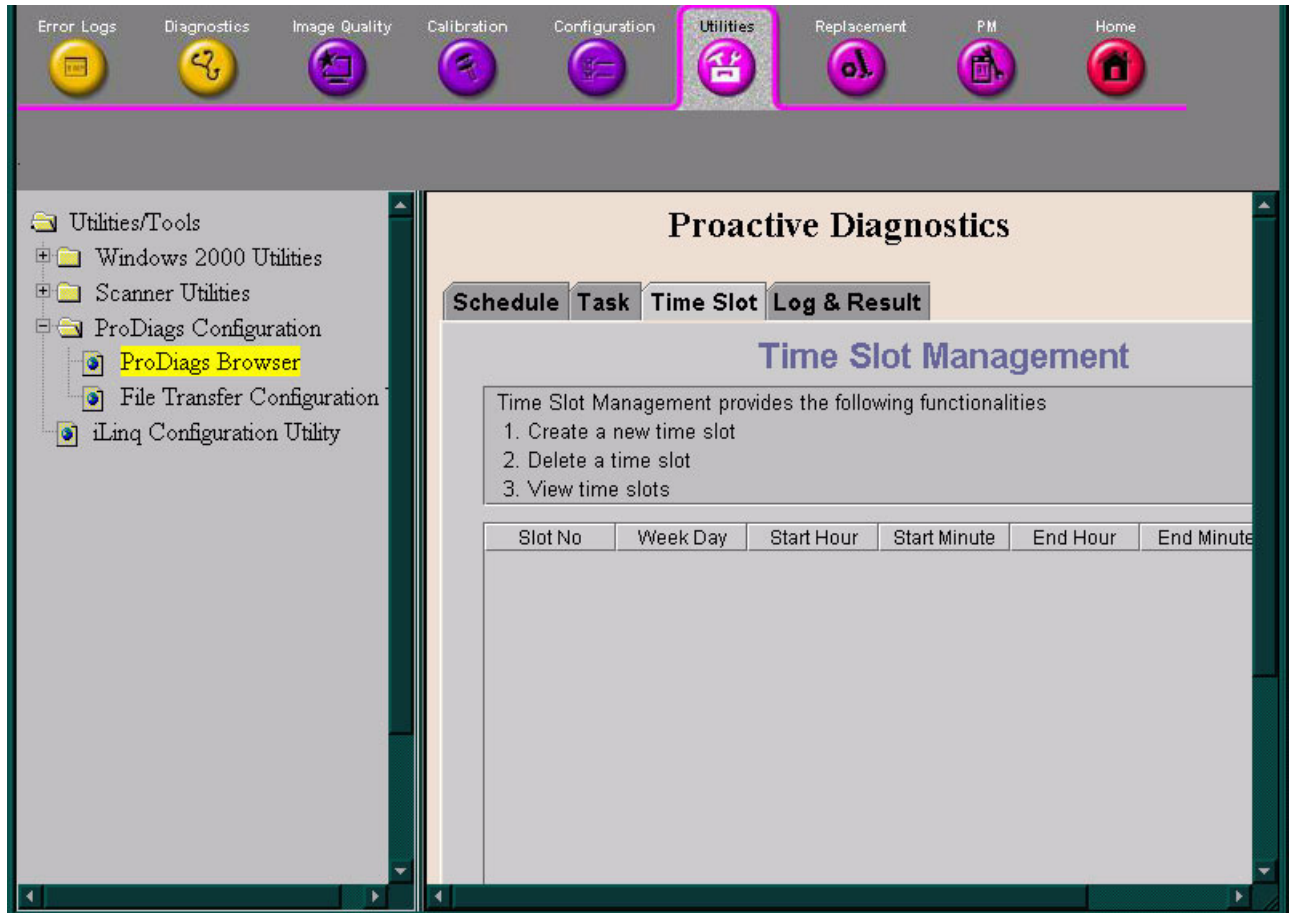

Figure 7-93 ProDiags Browser - Time Slot

The **Time Slot** tab indicates the time slots available for setting tasks.

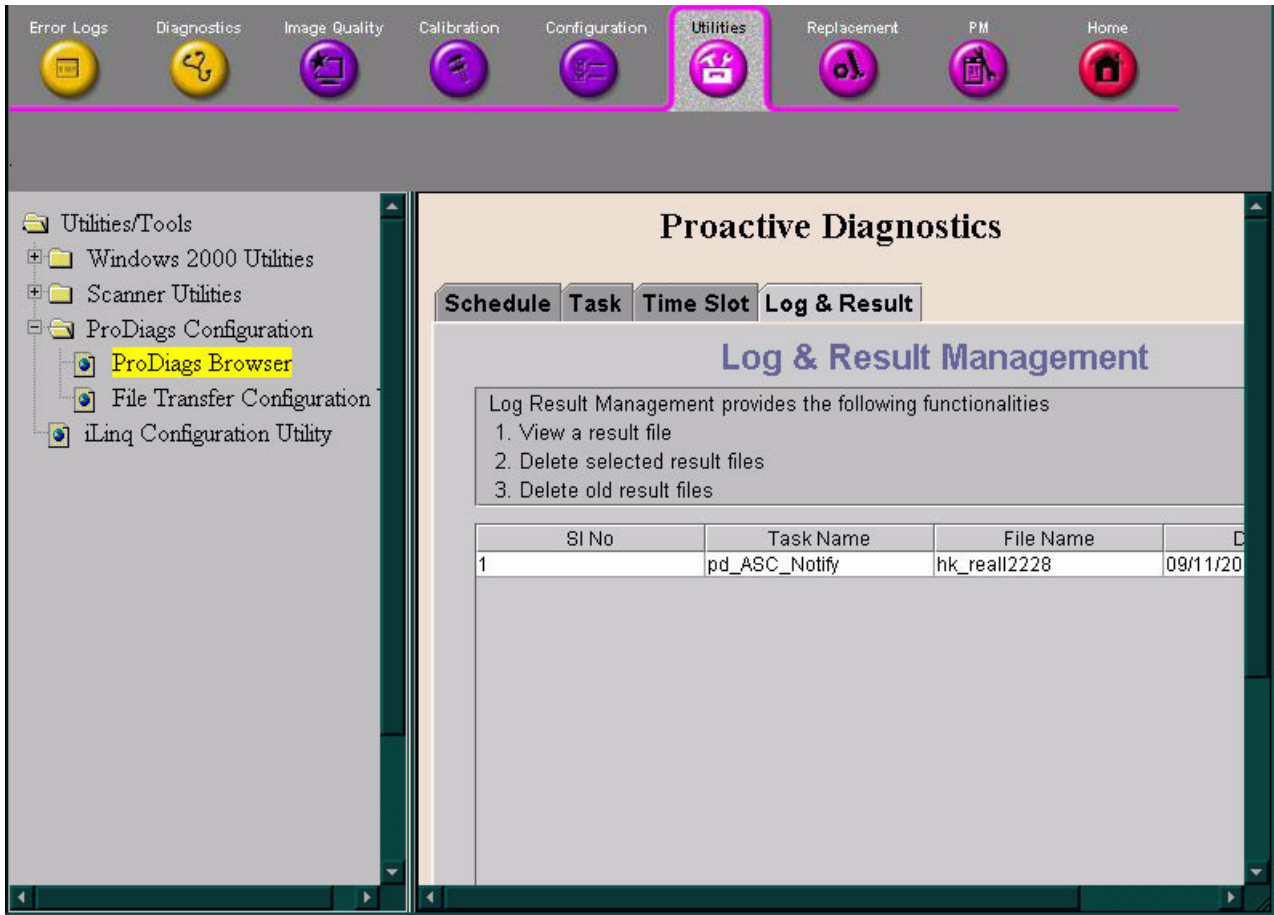

Figure 7-94 ProDiags Browser - Log and Result

The **Log & Result** tab indicates the logs and results of any tasks that have been performed.

At any of the above-mentioned tabs, you can *Add* or *Delete* a task from the list of displayed tasks.

7-5-8-3-2 File Transfer Configuration

The **File Transfer Configuration** utility can be used to transfer files to the GE Service center. Follow the on-screen instructions as shown below.

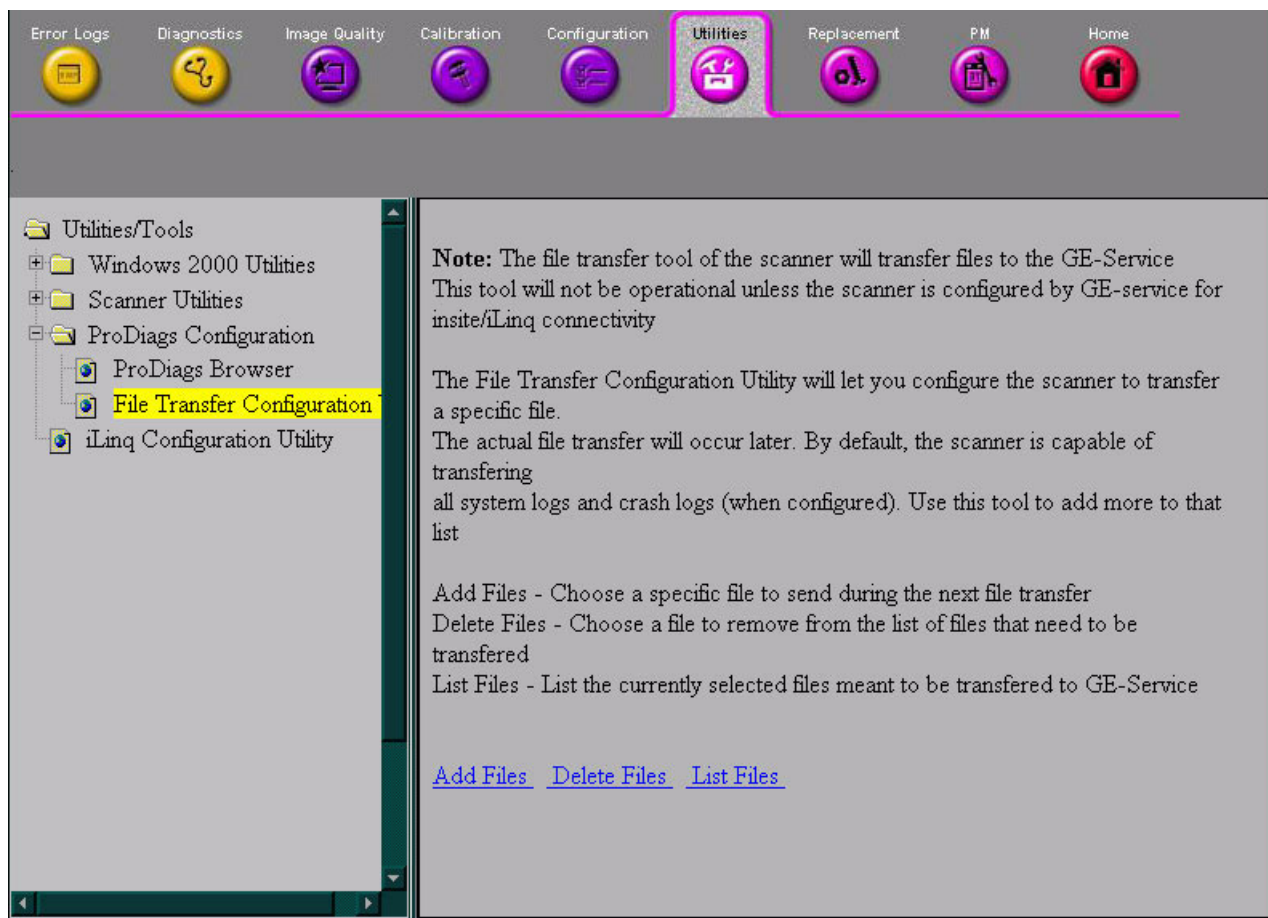

Figure 7-95 File Transfer Configuration

7-5-8-3-3 iLinq Configuration Utility

When the **iLinq Configuration Utility** option is selected in the left pane of the Configuration page (see [Figure 7-96](#) below) - the *InSite Interactive Platform Configuration* window is displayed, as shown in [Figure 7-97](#) on page 7-121.

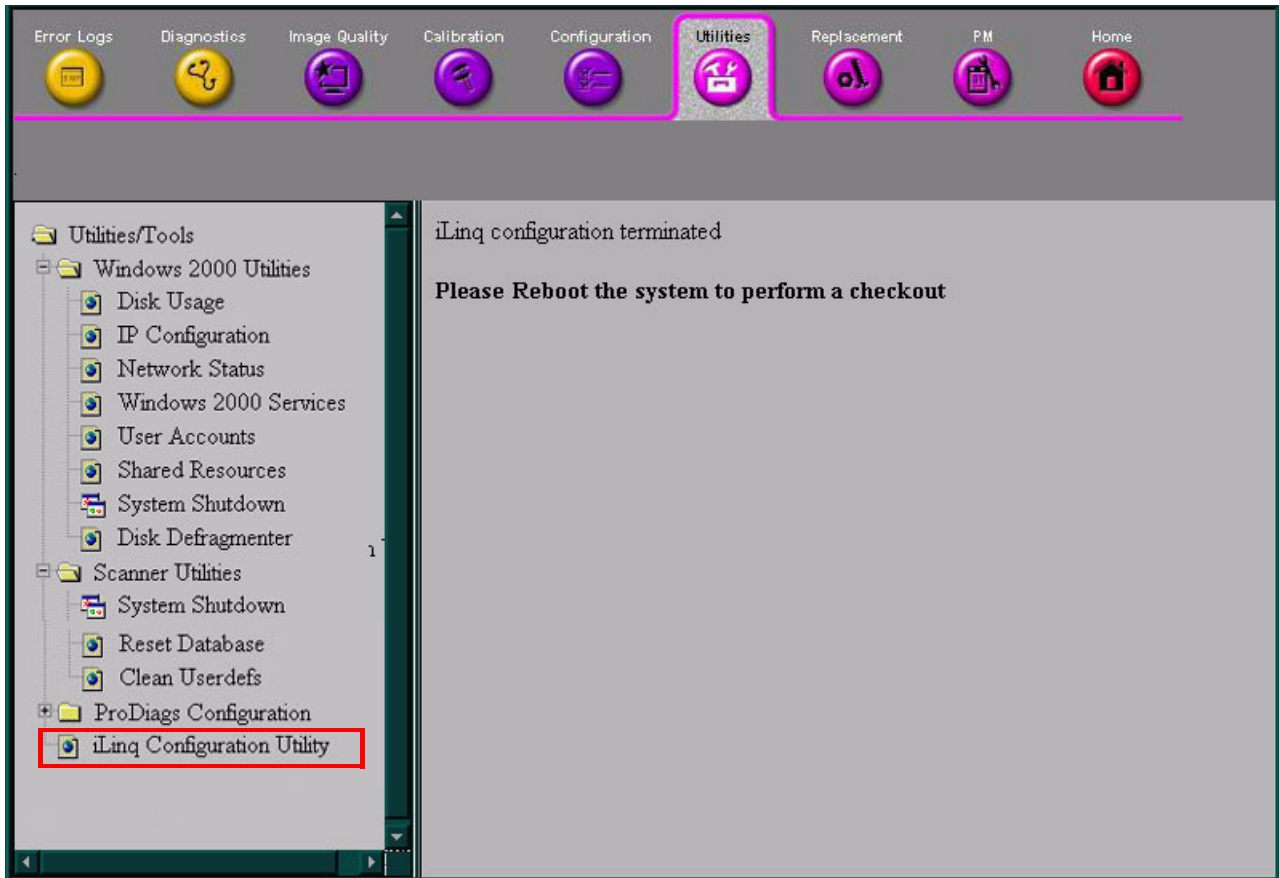

Figure 7-96 iLinq Configuration Utility

Click **Accept** and select the modem device as the communication device to the OLC in the **Device Connection** tab, also shown below.

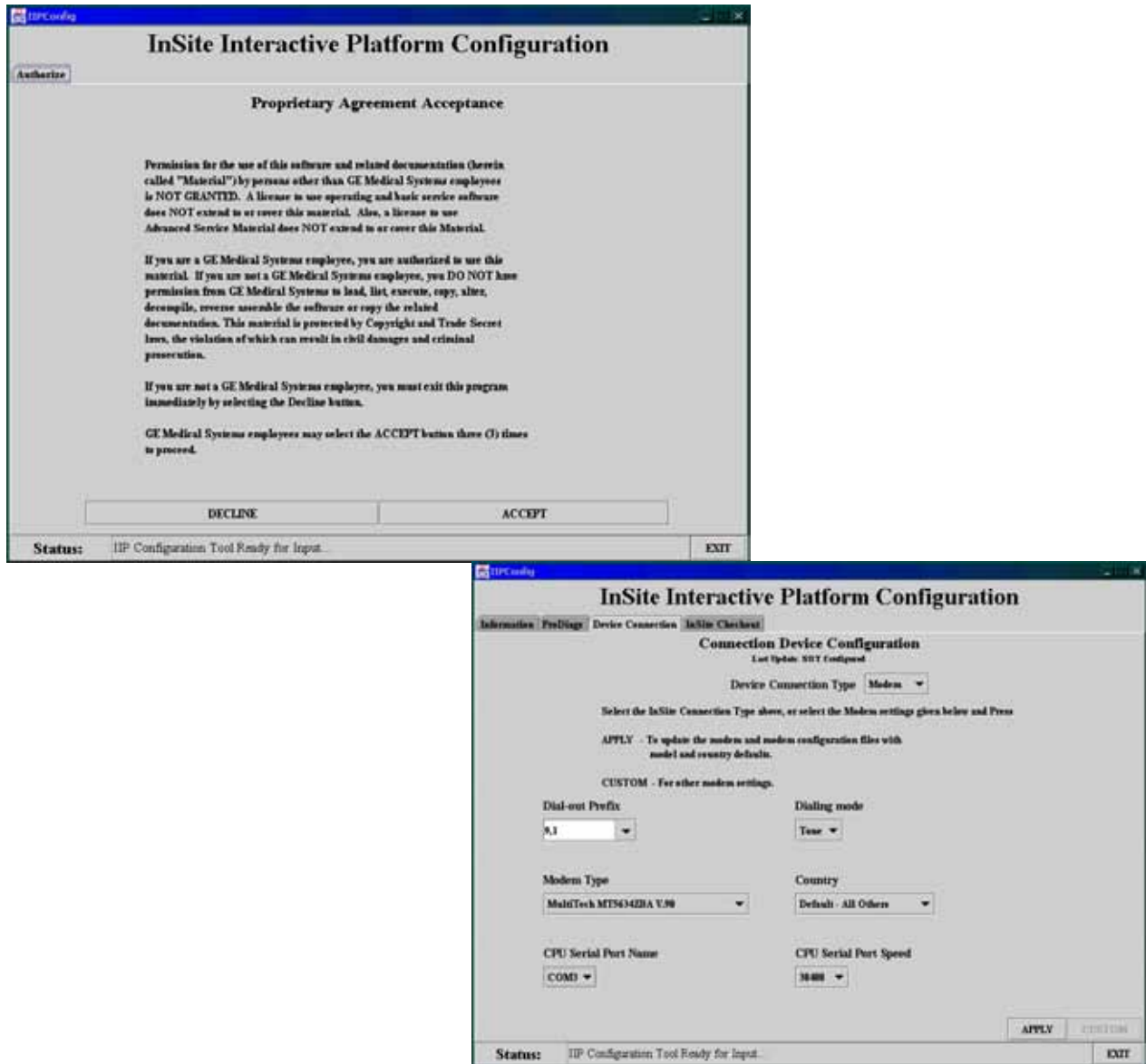

Figure 7-97 InSite Interactive Platform Configuration

Contact the OLC to receive all the setup information required for the **InSite Checkout** tab, as shown below. When all the settings have been entered, click the **CHECKOUT NOW** button twice. The OLC will attempt to communicate with your ultrasound unit via the modem. The unit should be connected to a direct telephone line, so that the OLC can dial in directly to the scanner.



Figure 7-98 InSite Checkout Tab

iLinq IP Save/Restore

The **iLinq IP Save/Restore** utility, which is accessed from the *System Configuration* window (under the *Technical Support* Tab), will allow you to save the iLinq IP settings to the hard disk, as described below.

iLinq IP Save Procedure:

- 1) In the System Configuration window, click on the **Technical Support** tab - see [Figure 7-99](#) below.

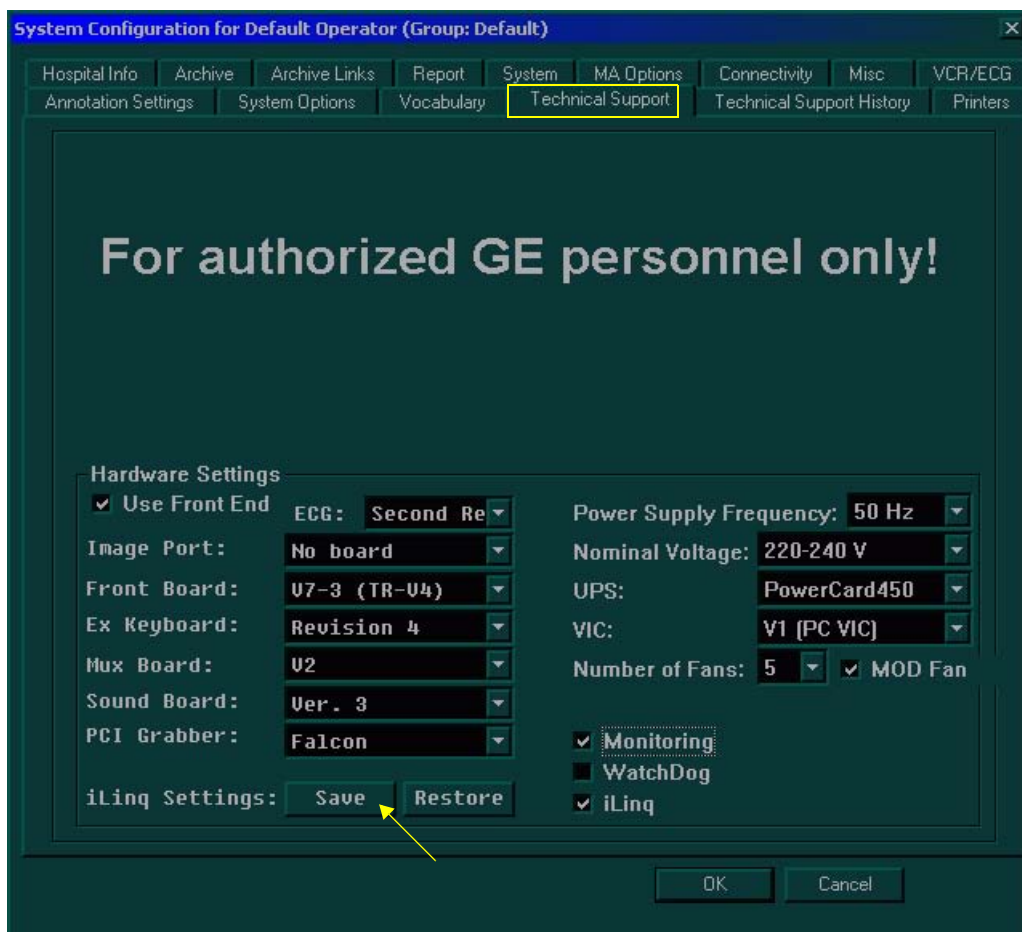

Figure 7-99 Technical Support Tab

- 2) Trackball to **iLinq Settings: Save** and press **Select**.
The system saves the presets to the disk.
- 3) TRACKBALL to **OK** and press **Select**. The scanning screen is re-displayed.

iLinq IP Restore Procedure:

When required (for example, after software re-installation), you can perform Restore of iLinq IP settings from the hard disk, as follows:

- 1) From the System Configuration window (under the *Technical Support* Tab - refer to [Figure 7-99](#), above) trackball to **iLinq Settings: Restore** and press **Select**.

A blank screen appears; wait for a while until the *phone and modem options* message is displayed then TRACKBALL to **OK** and press **Select**.

- 2) Wait while the restore process is running - this may take a while.
When complete, a message is displayed prompting for system shutdown.
- 3.) Perform a full system shutdown, then re-start the Vivid™ 3 system.

The restored iLinq IP settings will now be operational.

7-5-9 Replacement Page

When the *Replacement* page is selected, as shown below, part replacement details and ordering information is displayed, as described in [Chapter 9 - Renewal Parts](#).

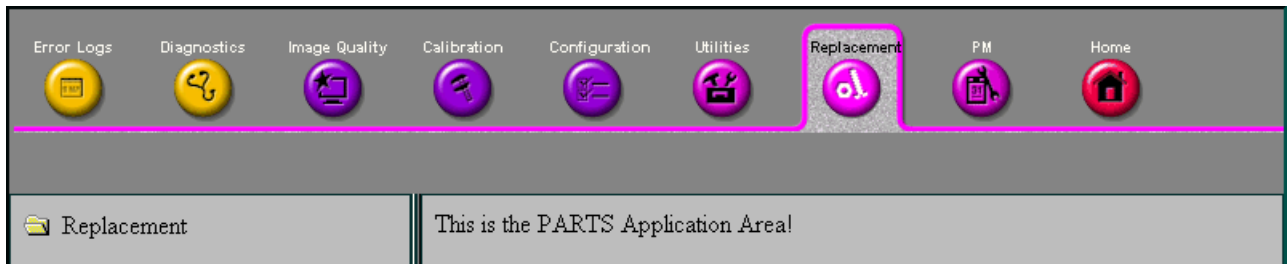

Figure 7-100 Replacement Page

Note: This page is not populated in this version.

7-5-10 PM Page

When the *PM* page is selected, as shown below, information about planned, proactive and preventive maintenance is displayed, as described in [Chapter 10 - Periodic Maintenance](#).

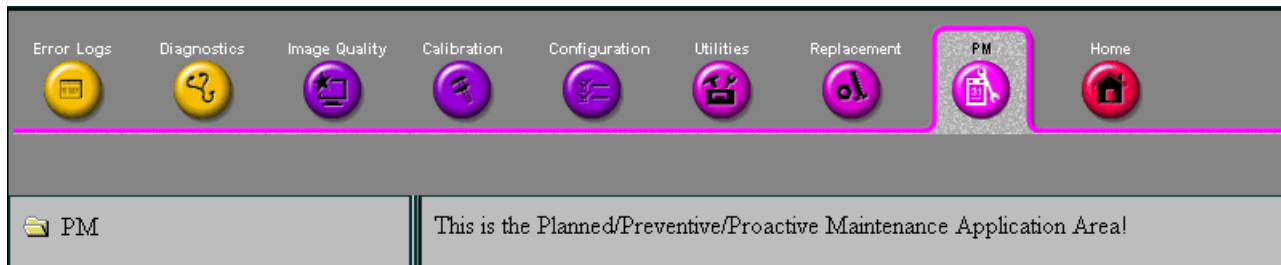

Figure 7-101 PM Page

Note: This page is not populated in this version.

Section 7-6 Automatic Error Log

The Vivid™ 3 automatically logs the software activity, sequences and error messages that occur during normal operation. Each day's activity is compressed into a single daily logger report, with a time stamp appearing in each line of the report. Additional user comments and screen captures, can also be included in the report. Each day's report is saved in the system for 90 days, during which time they can be recalled and saved to disk.

7-6-1 Adding Comments to the Daily Logger Report

In addition to automatic activity logging, you can also enter your own comments, as well as screen captures pertaining to system functionality. These comments are saved as part of the daily logger report.

- 1) When an error occurs, press <Ctrl+F> (or <Alt+D>) on the alphanumeric keyboard. The *Failure Report* window is displayed, as shown below:

The screenshot shows a 'Failure Report' window with the following elements:

- Failure Report** (Section Header)
- Failure date:** 24 Aug 2003
- Failure time:** 23:44
- Problem Description:** A text area containing the placeholder text: "Here the user may type a short description of any issue related to the current screen display (Click "Add to History" button to save into the log file)".
- Attach screen snapshot**
- Attach DB**
- Add To History** (Button)
- Store Daily History** (Section Header)
- 08/24/2003 (Dropdown menu)
- Save Log** (Button)
- Close** (Button)

Figure 7-102 Failure Report Window

- 2) In the **Problem Description** area, enter a description of the problem, and any additional comments. If required, select the **Attach screen snapshot** checkbox to include a snapshot of the screen as it appeared before the *Failure Report* window was accessed.
- 3.) If required, select the **Attach DB** checkbox to attach information about the system archive and database to the report. This information will be added to the zip file.
- 4) Trackball to the **Add To History** button and press **Select**.
- 5) Trackball to the **Close** button and press **Select**.

7-6-2 Saving the Logger Report

The daily logger reports are retained in the system for 90 days, during which time they can be recalled. In addition, each report can be downloaded to a floppy disk, for example in order to be sent to the servicing center.

- 1) Press <Ctrl+F> (or <Alt+D>) on the alphanumeric keyboard. The *Failure Report* window is displayed, as shown in [Figure 7-102](#) on page 7-126.
- 2) Select the date on which the report that you want to save was generated from the calendar displayed when you expand the drop-down list in the **Store Daily History** area, as shown below. By default, the current date is displayed.

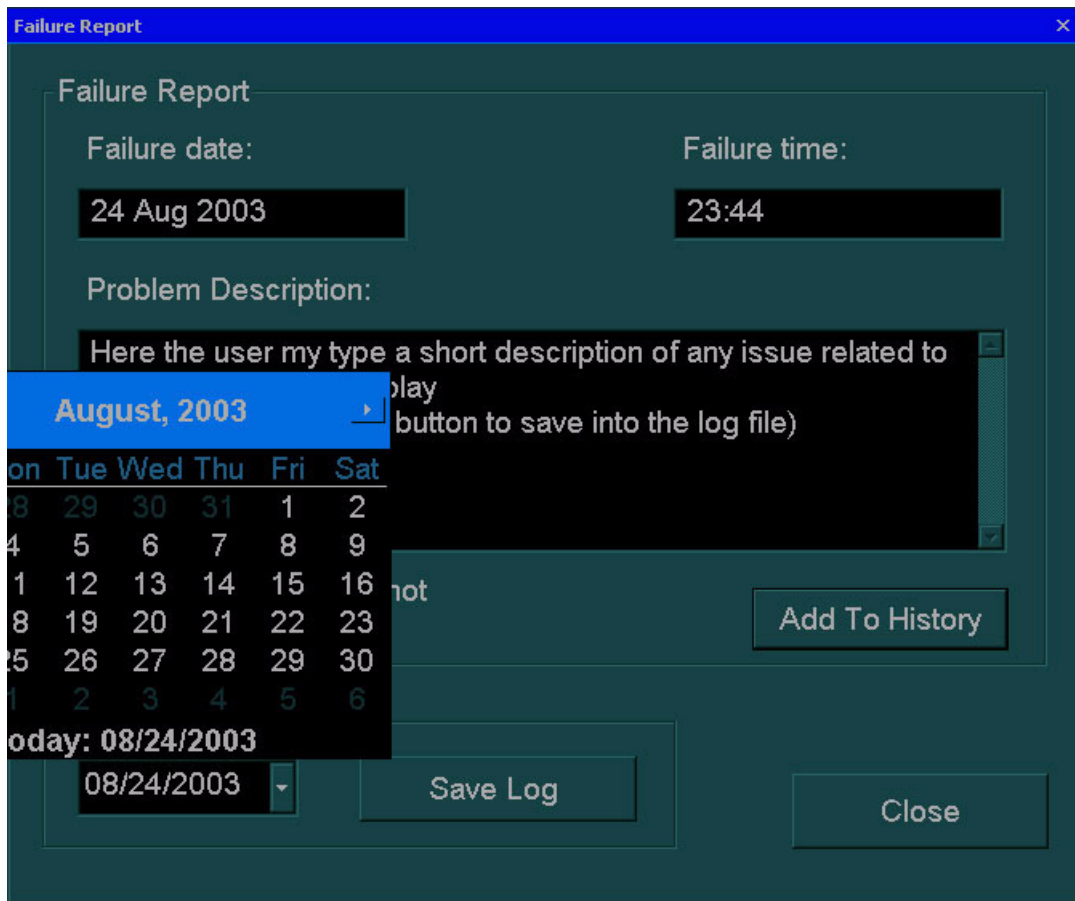

Figure 7-103 Failure Report Calendar

- 3) Insert an empty PC formatted diskette.

Note: An individual empty diskette is required for each report.

- 4) Trackball to the **Save To Diskette** button and press **Select**. The report is copied to the diskette as a single zipped file. If the file is too large for the diskette, insert additional diskettes as indicated. The file name will be identical on each diskette. When sending the report, send each file in a separate e-mail, indicating the correct order of the files.

7-6-3 Sending the Logger Report

Send the zipped file as an attachment to an e-mail message. In the e-mail message, briefly describe the problem and indicate approximately what time of day it occurred.

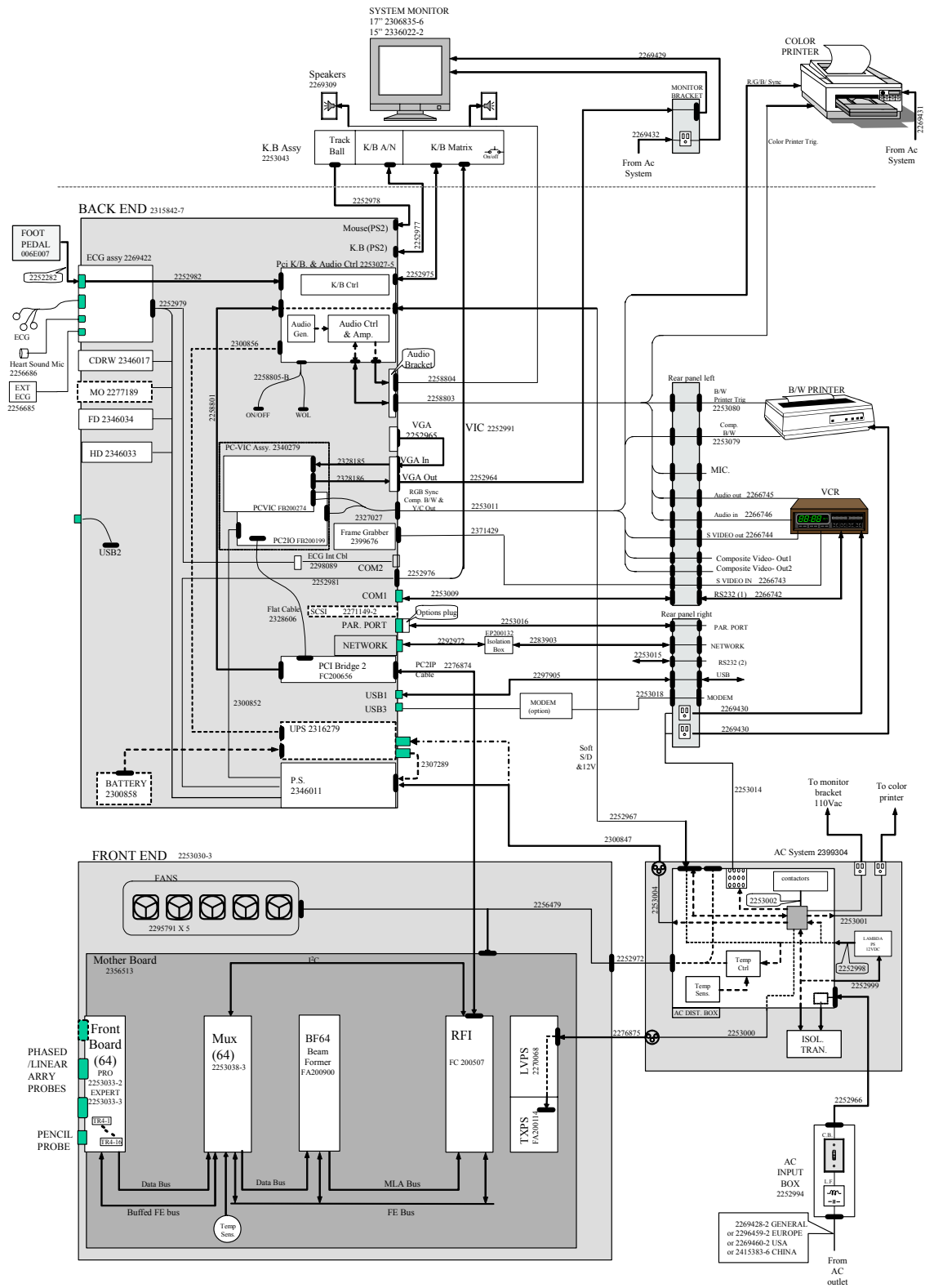

Figure 7-104 System Cabling Diagram - Vivid™ 3 BT03 (RFI Configuration)

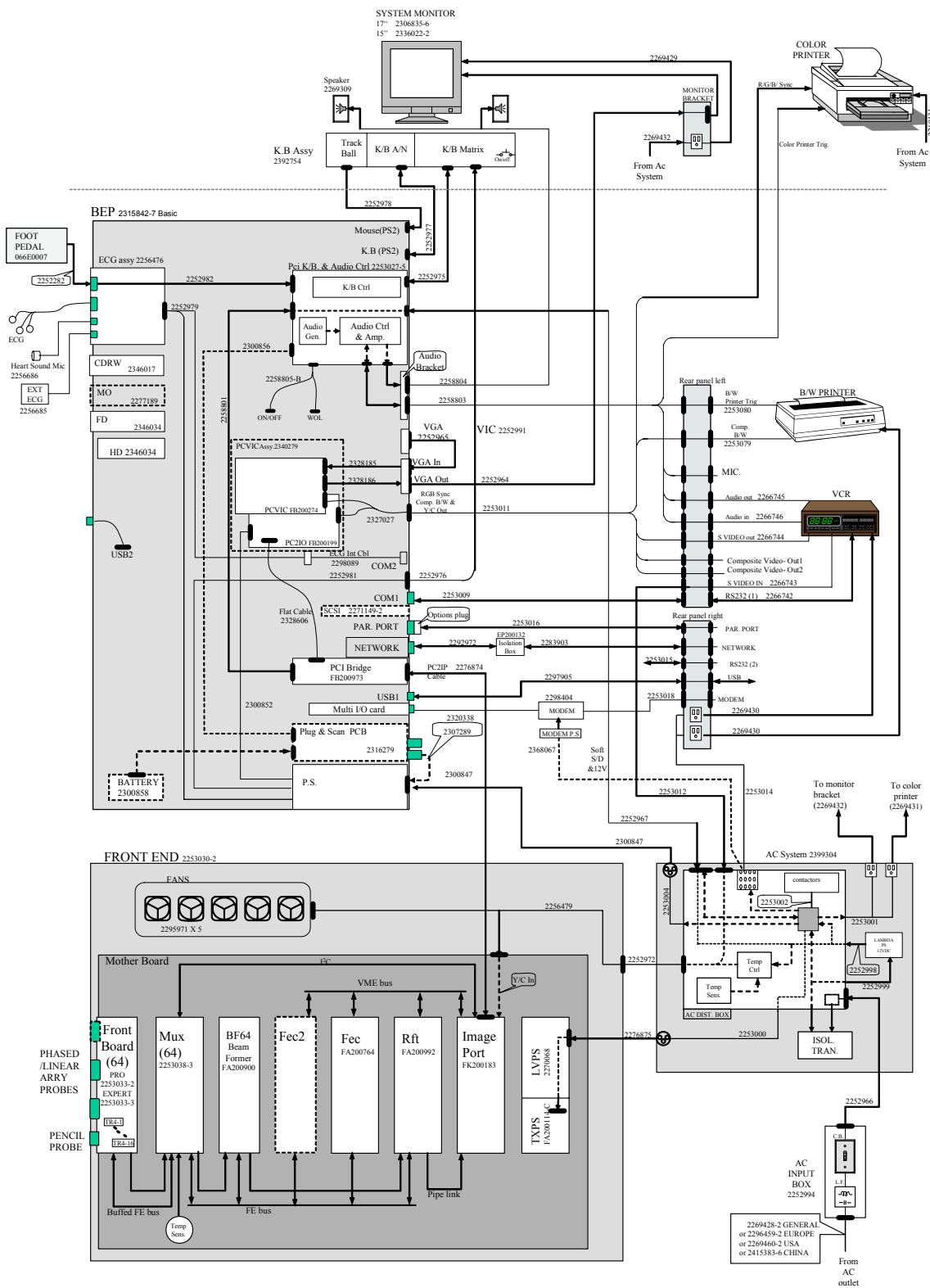

Figure 7-105 System Cabling Diagram - Vivid™ 3 BT03 (RFT Configuration)

Chapter 8

Replacement Procedures

Section 8-1 Overview

8-1-1 Purpose of Chapter 8

This chapter provides replacement procedures for system parts.

Table 8-1 Contents in Chapter 8

Section	Description	Page Number
8-1	Overview	8-1
8-2	Cover Replacement Procedures	8-2
8-3	Control Console Components Replacement	8-27
8-4	Front End Parts Replacement	8-44
8-5	Back End Parts Replacement	8-54
8-6	Lower Section Components Replacement	8-99
8-7	Software Loading	8-121
8-8	Peripherals	8-123

Section 8-2 Cover Replacement Procedures

8-2-1 Overview of Covers

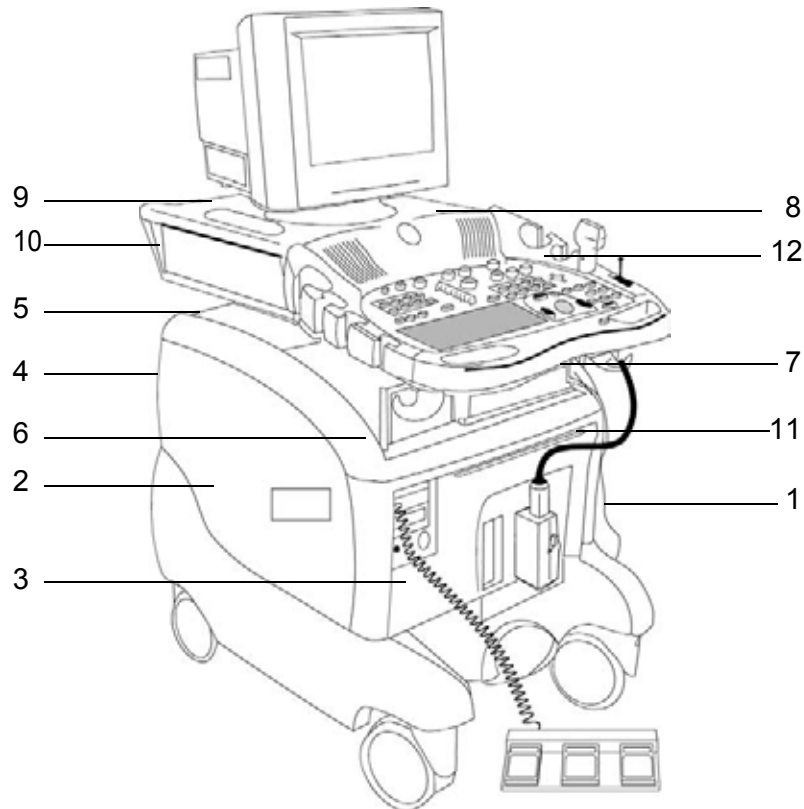

Figure 8-1 Vivid™ 3 Ultrasound Unit

Table 8-2 Vivid™ 3 Ultrasound Unit Covers (Figure 8-1)

Label	Item	Label	Item
1	Right Side Cover	7	Bottom Keyboard Cover (not shown)
2	Left Side Cover	8	Speakers Cover
3	Front Cover	9	Control Console Top Cover
4	Rear Cover (not shown)	10	Control Console Bottom Cover
5	Connector Panels Cover	11	Air Filter
6	Top Cover (Lower Section)	12	Probe Holders

8-2-1-1 Preparations

Shut down the Vivid™ 3 ultrasound unit, as described in [Chapter 3 - Installation](#).



DANGER: Electrical hazards exist at several points in the system. Familiarize yourself with all hazardous voltages and high current levels before removing any of the covers.



DANGER: DO NOT wear the ESD wrist band strap when removing parts from the power supply unit. Before removing any part of the power unit, turn the power OFF and disconnect the power cord.



CAUTION: Before removing circuit boards, turn the power OFF and wear the ESD wrist band strap.

8-2-1-2 Order of Cover Removal

Remove the side covers in the following order:

- Side Covers, as described on [page 8-4](#).
- Front Cover, as described on [page 8-5](#).
- Rear Cover, as described on [page 8-7](#).
- Connector Panels, as described on [page 8-8](#).
- Top Cover (lower section), as described on [page 8-9](#).
- Gas Spring Cover, as described on [page 8-13](#).
- Bottom Keyboard Cover, as described on [page 8-14](#).
- Speakers Cover, as described on [page 8-16](#).
- Control Console Bottom Cover, as described on [page 8-17](#).
- Control Console Top Cover, as described on [page 8-20](#).

8-2-2 Side Covers Replacement Procedures

8-2-2-1 Tools

Use the appropriate Phillips-type screw drivers, as indicated in the side cover replacement procedures.

8-2-2-2 Preparations

Shut down the Vivid™ 3 ultrasound unit, as described in [Chapter 3 - Installation](#).

8-2-2-3 Side Covers Removal Procedure

- 1) Remove the screw from each of the wheel arches of the two side covers (four in total), an example of which is shown below. To easily access the screws, turn the wheels inwards by 90 degrees.

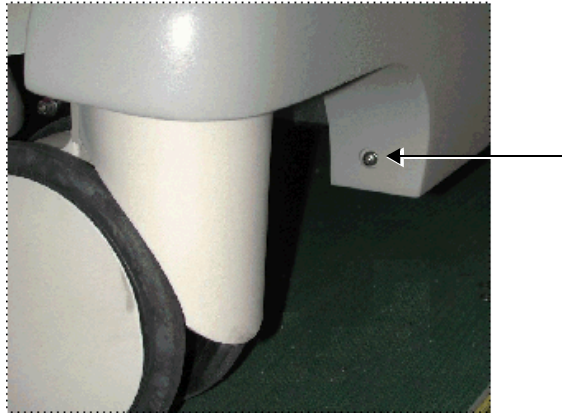

Figure 8-2 Wheel Arch Screw

- 2) Slide the *right* side cover down and outwards until it is free from its holders.
- 3) Slide the *left* side cover down and outwards until it is free from its holders.

8-2-2-4 Side Covers Installation Procedure

- 1) Slide the *right* side cover up and inwards until it fits in place.
- 2) Slide the *left* side cover up and inwards until it fits in place.
- 3) Fasten the screw in each of the wheel arches of the two side covers (four in total), an example of which is shown in [Figure 8-2](#), above. To easily access the screws, turn the wheels inwards by 90 degrees.

8-2-3 Front Cover and Air Filter Replacement Procedures

8-2-3-1 Tools

Use the appropriate Phillips-type screw drivers, as indicated in the front cover and air filter replacement procedures.

8-2-3-2 Preparations

Shut down the Vivid™ 3 ultrasound unit, as described in [Chapter 3 - Installation](#).

8-2-3-3 Front Cover Removal Procedure

- 1) Pull out and remove the air filter, as shown below:



Figure 8-3 Air Filter

- 2) Remove the side covers, as described [Side Covers Replacement Procedures](#) on page 8 - 4.
- 3) The front cover is secured to the base of the main metal frame by a metal bracket on each side. Remove the upper screw from each bracket, and loosen the lower screw securing the bracket to the metal frame, as shown below:

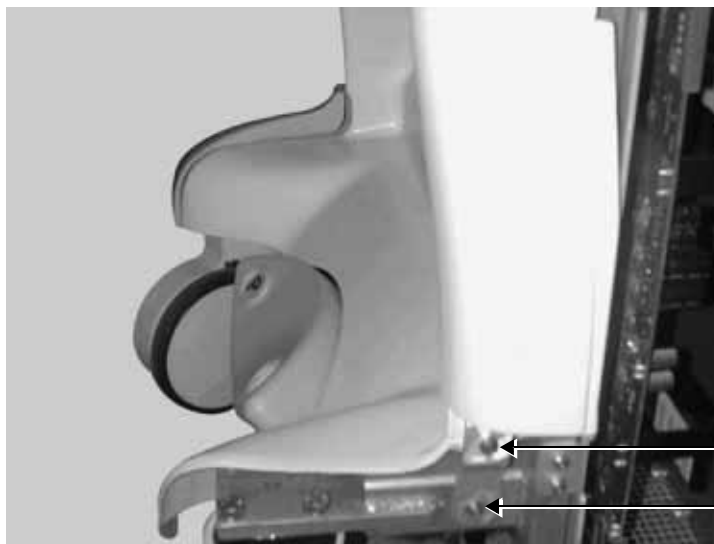

Figure 8-4 Front Cover Bracket Screws

- 4) Remove the three screws located across the front of the top cover, shown below:

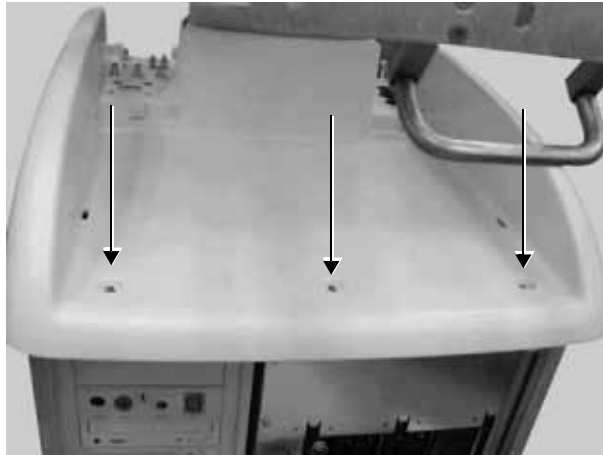

Figure 8-5 Top Cover Screws (Lower Section)

- 5) In order to free the front cover, grip the cover by its lower sides, and push upwards while pulling it towards you.

8-2-3-4 Front Cover Installation Procedure

- 1) Return the front cover to its original position at the front of the unit, taking care to first insert its upper edge under the top cover.
- 2) Fasten the front cover with the three screws at the edge of the top cover, as shown in [Figure 8-5](#), above.
- 3) Fasten the left and right brackets at the lower end of the front cover, one each side, by tightening each bracket with its two screws to the main metal frame, as shown in [Figure 8-4](#) on page 8-5.
- 4) Install the side covers, as described [Side Covers Installation Procedure](#) on page 8 - 4.
- 5) Insert the air filter to its original location, as shown in [Figure 8-3](#) on page 8-5.

Note: It is recommended to clean the filter before returning it to its original location, as described in [Chapter 10 - Periodic Maintenance](#).

8-2-4 Rear Cover Replacement Procedures

8-2-4-1 Tools

Use the appropriate Phillips-type screw drivers, as indicated in the rear cover replacement procedures.

8-2-4-2 Preparations

Shut down the Vivid™ 3 ultrasound unit, as described in [Chapter 3 - Installation](#).

8-2-4-3 Rear Cover Removal Procedure

- 1) Remove the side covers, as described in the [Side Covers Replacement Procedures](#) on page 8 - 4.
- 2) Remove the four screws that secure the rear cover in position. Two screws are located on the sides of the rear cover, as shown below. The other two screws are located in the AC Input Box Unit, as shown in [Figure 8-7](#) below.



Figure 8-6 Rear Cover Screws



Figure 8-7 Rear Cover Screws in AC Input Box Unit

- 3.) Remove the rear cover.

8-2-4-4 Rear Cover Installation Procedure

- 1) Return the rear cover in its original position.
- 2) Insert the four screws and secure the rear cover in position. Two screws are located on the sides of the rear cover, as shown in [Figure 8-6](#), above. The remaining two screws are located in the AC Input Box Unit, as shown in [Figure 8-7](#), above.
- 3) Install the side covers, as described in the [Side Covers Installation Procedure](#) on page 8 - 4.

8-2-5 Connector Panels Cover Replacement Procedures

8-2-5-1 Tools

Use the appropriate Phillips-type screw drivers, in indicated in the connector panels cover replacement procedures.

8-2-5-2 Preparations

Shut down the Vivid™ 3 ultrasound unit, as described in [Chapter 3 - Installation](#).

8-2-5-3 Connector Panels Cover Removal Procedure

- 1) Remove the two screws, located one on either side of the cover.
- 2) Lift and remove the cover.



Figure 8-8 Connector Panels Cover

8-2-5-4 Connector Panels Cover Installation Procedure

- 1) Return the cover to its original position above the connector panels.
- 2) Insert the two screws, located one on either side of the cover, and tighten them firmly.

8-2-6 Top Cover (Lower Section) Replacement Procedures

8-2-6-1 Tools

Use the appropriate Phillips-type screw drivers, and a wire cutter as indicated in the replacement procedures for the lower section of the top cover.

8-2-6-2 Preparations

Shut down the Vivid™ 3 ultrasound unit, as described in [Chapter 3 - Installation](#).

8-2-6-3 Top Cover Lower Section Removal Procedure

- 1) Remove the side covers, as described in the [Side Covers Replacement Procedures](#) on page 8 - 4.
- 2) Remove the rear cover, as described in the [Rear Cover Replacement Procedures](#) on page 8 - 7.
- 3) Raise the control console to its *maximum* height.
- 4) Remove the two screws located in the brackets underneath the lower section of the top cover, one on either side of the unit, as shown below:

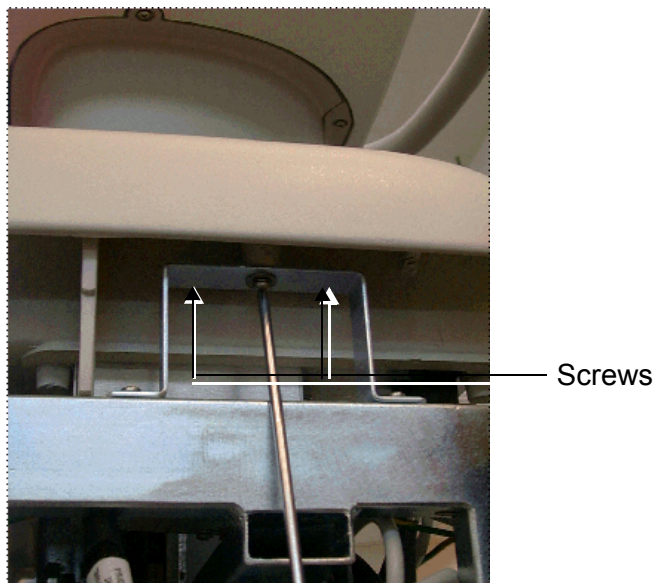

Figure 8-9 Top Cover (Lower Section) Screws

- 5) Remove the connectors panels cover, as described the [Connector Panels Cover Replacement Procedures](#) on page 8 - 8.
- 6) Unplug all the peripheral cables connected to the rear connector panels.

Note: Pay attention to the location of each cable, as each one must be reconnected to its original location during the installation process.

- 7) Cut the cable tie holding the AC cable (P/N 2253013) to the other cables, and unplug the AC cable from the AC Outlet in the AC Distribution Box, as shown below:

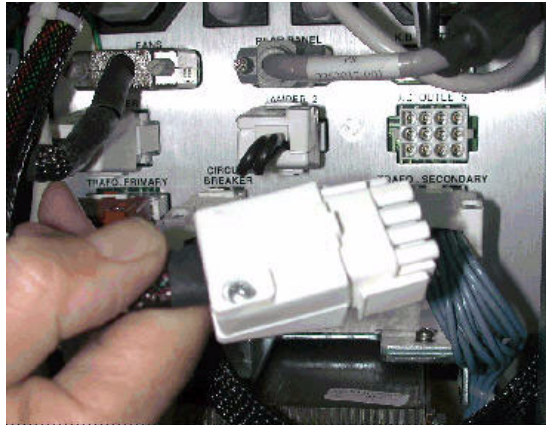

Figure 8-10 AC Distribution Box Cables



CAUTION: Do not unplug any cables from below the rear panels, except for those indicated in this procedure.

- 8) Viewing the unit from behind, there are two small metal plates at the back of the top cover, each with two screws. Remove only the outer screw from each plate, releasing the small section of the collar with its two metal plates attached, as shown below:



Figure 8-11 Top Cover Collar

- 9) Remove the section of the collar released in the previous step, leaving an open gap at the rear of the top cover, as shown below:



Figure 8-12 Top Cover with Collar Removed

- 10) Remove the four screws that secure each connector panel to the top cover.
- 11) Gently pull the rear panels backwards, leaving them hanging loosely on their cables, as shown below:



Figure 8-13 Connector Panels - Loosened

- 12) Remove the two screws securing the rear section of the gas spring cover, and then remove this cover.
- 13) Remove the three screws securing the remaining section of the gas spring cover, shown below, and lower it into the collar of the top cover.

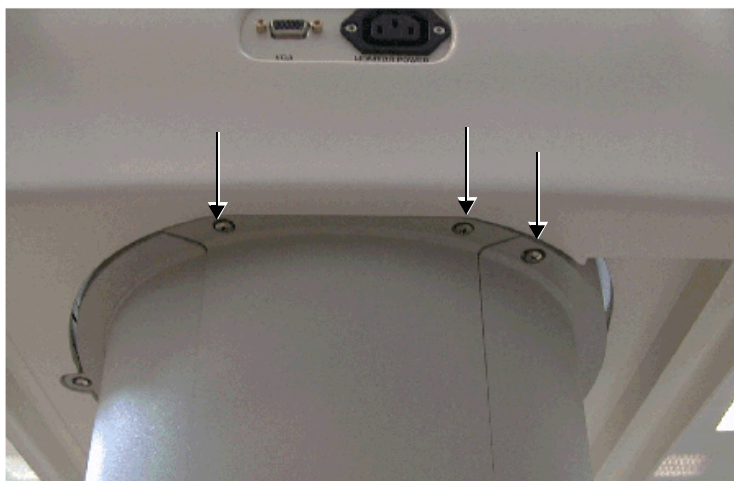

Figure 8-14 Gas Spring Cover Screws



CAUTION: The remaining section of the gas spring cover cannot be removed at this stage. Do not attempt to remove it.

- 14) Remove the three screws located at the front edge of the top cover, and allow it to sink down into the top cover collar.
- 15) Slightly lift the top cover, together with the remaining section of the gas spring cover, and turn them 90 degrees *clockwise*.
- 16) Keep the opened gap of the gas spring cover parallel to the opened gap of the top cover's collar, and pull them out together in a *clockwise* direction.
- 17) Remove the gas spring cover section from the top cover.

8-2-6-4 Top Cover Lower Section Installation Procedure

- 1) Return the gas spring cover section back to its original position in the top cover.
- 2) Align the opened gap of the gas spring cover to be in parallel with the opened gap of the top cover collar.
- 3) Hold the top cover and the gas spring cover section so that they are at a 90-degree angle to the front of the unit, then insert them from the *left* side of the unit through their opened gap.
- 4) Insert and screw the three screws located at the top edge of the top cover, shown in [Figure 8-5](#) on page 8-6.
- 5) Lift the gas cover spring cover from the top cover and fasten it with the three screws in its original location.
- 6) Return the rear section of the gas spring cover to its original position and fasten it with the two screws shown in [Figure 8-14](#) on page 8-11.
- 7) Gently fit the left and right connector panels back to their original position on the top cover and fasten each with its four screws.
- 8) Mount the small section of the top cover collar, closing the open gap at the rear of the top cover, and fasten it to the top cover with the two screws shown in [Figure 8-11](#) on page 8-10.
- 9) Plug in the AC cable (P/N 2253013) to the AC Dis. Box, shown in [Figure 8-10](#) on page 8-10, and secure the cable to the other cables with a tie-wrap.
- 10) Plug all peripheral cables into their original locations in the connector panels.
- 11) Return the connectors panels cover, as described in the [Connector Panels Cover Installation Procedure](#) on page 8 - 8.
- 12) Fasten the top cover with the two screws located in the brackets underneath the top cover, on either side of the unit, as shown in [Figure 8-9](#) on page 8-9.
- 13) Return the rear cover, as described in the [Rear Cover Installation Procedure](#) on page 8 - 7.
- 14) Return the side covers, as described in the [Side Covers Installation Procedure](#) on page 8 - 4.

8-2-7 Gas Spring Cover Replacement Procedure

8-2-7-1 Tools

Use the appropriate Phillips-type screw drivers, as indicated in the gas spring cover replacement procedures.

8-2-7-2 Preparation

Shut down the Vivid™ 3 ultrasound unit, as described in [Chapter 3 - Installation](#).

8-2-7-3 Gas Spring Cover Removal Procedure

The procedure for removing the gas spring cover is identical to the procedure for removing the lower section of the top cover, as described in the [Top Cover Lower Section Removal Procedure](#) on page 8 - 9.

8-2-7-4 Gas Spring Cover Installation Procedure

The procedure for installing the gas spring cover is identical to the procedure for installing the lower section of the top cover, as described in the [Top Cover Lower Section Installation Procedure](#) on page 8 - 12.

8-2-8 Bottom Keyboard Cover Replacement Procedure

8-2-8-1 Tools

Use the appropriate Phillips-type screw drivers, as indicated in the bottom keyboard cover replacement procedures.

8-2-8-2 Preparation

Shut down the Vivid™ 3 ultrasound unit, as described in [Chapter 3 - Installation](#).

8-2-8-3 Bottom Keyboard Cover Removal Procedure

- 1) Raise the control console monitor to its *maximum* height.
- 2) Remove the screws in each of the probe cable hooks located underneath the keyboard, and then remove the cable hooks.



Figure 8-15 Removing Probe Cable Hooks under Keyboard Cover

- 3) With one hand, hold the Up/Down (height adjustment) handle, while pulling the cover down towards you with your other hand until the cover is free.
- 4) Lower the rear end of the bottom keyboard cover and free it from the Up/Down handle by passing the handle through the slot on the cover, as shown [Figure 8-16](#) below.



Figure 8-16 Removing the Bottom Keyboard Cover

8-2-8-4 Bottom Keyboard Cover Installation Procedure

- 1) Raise the control console monitor to its *maximum* height.
- 2) Position the bottom keyboard cover so that the Up/Down (height adjustment) handle is correctly aligned with the slot on the cover.
- 3) With one hand, lift the bottom keyboard cover upwards while using the other hand to guide the Up/Down handle down through the slot in the cover. Push the cover all the way up to return it to its original location (refer to [Figure 8-16](#), above).
- 4) Return the cable hooks to their original position underneath the keyboard and fasten them securely with their screws - refer to [Figure 8-15](#) on page 8-14.

8-2-9 Speaker Cover Replacement Procedure

8-2-9-1 Tools

Use the appropriate Phillips-type screw drivers, as indicated in the speakers cover replacement procedures.

8-2-9-2 Preparation

Shut down the Vivid™ 3 ultrasound unit, as described in [Chapter 3 - Installation](#).

8-2-9-3 Speaker Cover Removal Procedure

- 1) Remove the bottom keyboard cover, as described in the [Bottom Keyboard Cover Removal Procedure](#) on page 8 - 14.
- 2) Remove the two screws located beneath the keyboard on either side, and the fastening bracket in the middle, that secure the speaker cover.

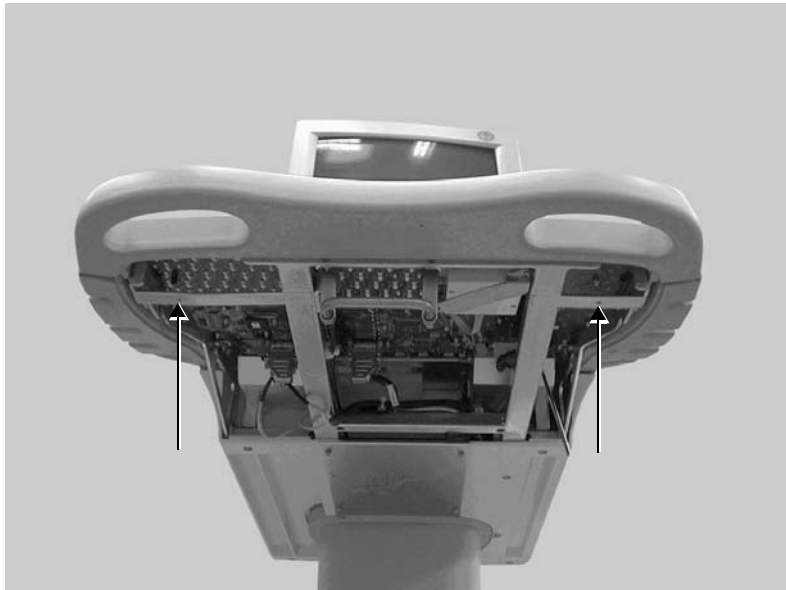

Figure 8-17 Speaker Cover Screws

- 3) Remove the speaker cover.

8-2-9-4 Speaker Cover Installation Procedure

- 1) Return the speaker cover to its original position.
- 2) Fasten the cover with two screws and bracket in the middle, beneath the keyboard. Before tightening the fastening screws, adjust the speaker cover to fit properly and symmetrically.
- 3) Install the bottom keyboard cover, as described in the [Bottom Keyboard Cover Installation Procedure](#) on page 8 - 15.

8-2-10 Control Console Bottom Cover (Upper Section) Replacement Procedure

8-2-10-1 Tools

Use the appropriate Phillips-type screw drivers, as indicated in the replacement procedures of the upper section of the control console's bottom cover.

8-2-10-2 Preparation

Shut down the Vivid™ 3 ultrasound unit, as described in [Chapter 3 - Installation](#).

8-2-10-3 Control Console Bottom Cover (Upper Section) Removal Procedure

- 1) Raise the control console to its *maximum* height.
- 2) Remove any peripherals.
- 3) Unplug the AC cable and VGA cable from the rear of the control console, as shown below:

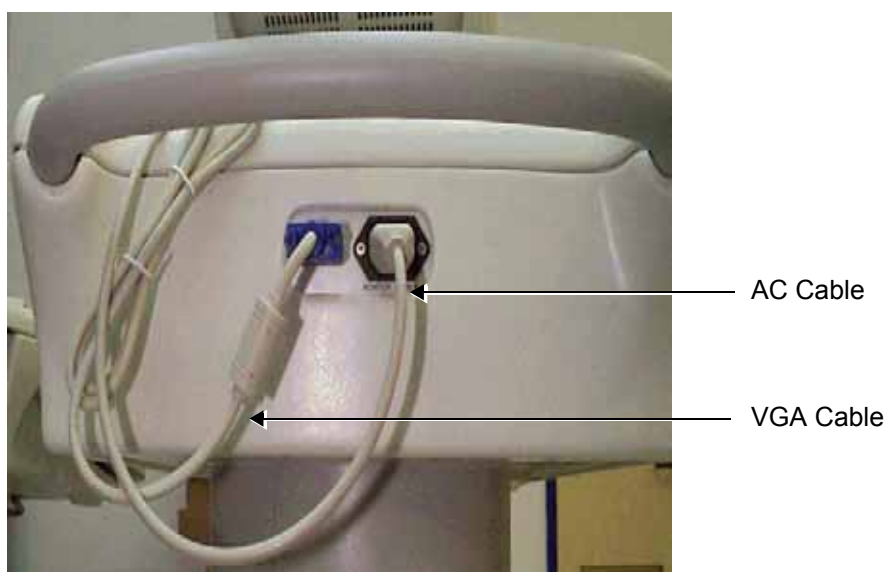

Figure 8-18 AC and VGA Cables at Rear of Control Console

- 4) Remove the two screws that fasten the rear section of the gas spring cover, and remove this section.
- 5) Remove the three screws that fasten the front section of the gas spring cover, and allow this section to sink down into the top cover collar.
- 6) Remove the two screws located on the white painted metal shelf inside the compartment that is located on the left side of the control console, and remove this shelf.

- 7) Loosen the two screws fastening the AC/VGA connectors box. These screws can be accessed from the opened space at the rear of the gas spring using a long screw driver, as shown below:



Figure 8-19 Removing Screws from the AC/VGA Connectors Box

- 8) Remove the four screws fastening the metal cover under the front part of the control console, and remove this cover.

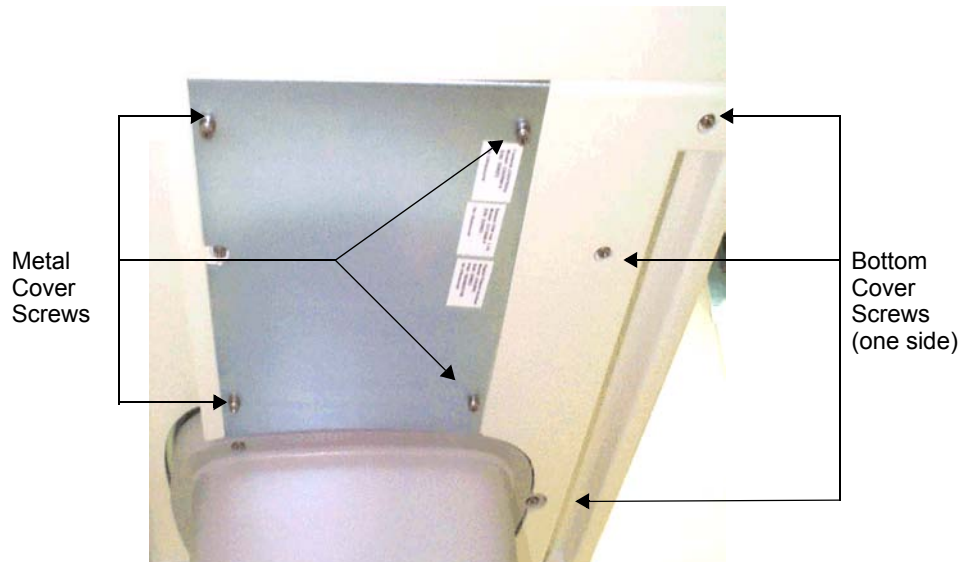

Figure 8-20 Removing the Metal Cover and Bottom Cover Screws

- 9) Remove the six screws fastening the bottom cover, three on either side.
- 10) Remove the bottom cover towards the rear of the machine.

8-2-10-4 Control Console Bottom Cover (Upper Section) Installation Procedure

- 1) Raise the control console to its *maximum* height.
- 2) Return the bottom cover to its original position at the rear of the machine.
- 3) Fasten the bottom cover with its six screws, three on either side.
- 4) Fasten the bottom metal cover in its original position with its four screws.
- 5) Tighten the two fastening screws of the AC/VGA connectors box. These screws can be accessed from the opened space at the back of the gas spring, using a long screw driver.
- 6) Return the white painted metal shelf to its original position inside the compartment located on the left side of the control console and fasten it at its base with its two screws.
- 7) Lift the front section of the gas spring cover from the top cover collar and fasten it with its three screws, as shown in [Figure 8-14](#) on page 8-11.
- 8) Return the rear section of the gas spring cover to its original position and fasten it with its two screws.
- 9) Plug the AC cable and VGA cable in to the rear of the control console, as shown in [Figure 8-18](#) on page 8-17.
- 10) Return all peripherals to their original positions.

8-2-11 Control Console Top Cover Replacement Procedure (Upper Section)

8-2-11-1 Tools

Use the appropriate Phillips-type screw drivers, as indicated in the replacement procedures for the upper section of the control console's top cover.

8-2-11-2 Preparation

Shut down the Vivid™ 3 ultrasound unit, as described in [Chapter 3 - Installation](#).

8-2-11-3 Control Console Top Cover Removal Procedure (Upper Section)

- 1) Raise the control console to its *maximum* height.
- 2) Remove any peripherals.
- 3) Unplug the AC cable and VGA cable from the rear of the control console, as shown in [Figure 8-18](#) on page 8-17.
- 4) Remove the monitor, as described in the [Vivid™ 3 Monitor 15" Replacement Procedure \(Samsung; P/N 2336022-2\)](#) on page 8 - 27.
- 5) Remove the two screws that fasten the rear section of the gas spring cover, and remove this section.
- 6) Remove the three screws that fasten the front section of the gas spring cover, and allow this section to sink down into the machine's top cover collar.
- 7) Remove the two fastening screws of the AC/VGA connectors box. These screws can be accessed from the opened space at the rear of the gas spring using a long screw driver, as shown in [Figure 8-19](#) on page 8-18. Move the AC/VGA box away, to free it from the top cover.
- 8) Using a short screw driver, remove six of the eight screws that fasten the top cover to the metal frame. The remaining two screws are located next to the AC/VGA connectors box, and can be accessed from the opened space at the rear of the gas spring using a long screw driver.

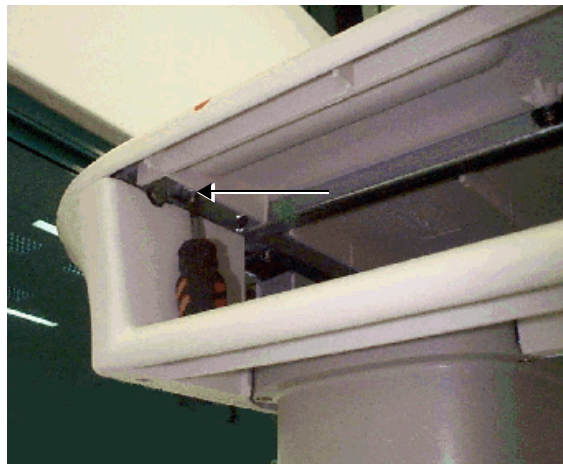

Figure 8-21 Removing Top Cover Screws (1)



Figure 8-22 Removing Top Cover Screws (2)

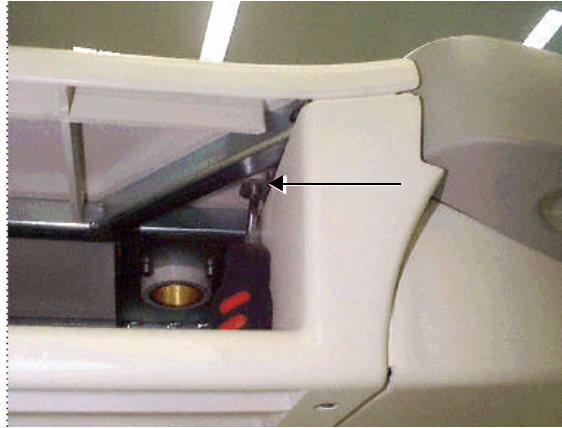

Figure 8-23 Removing Top Cover Screws (3)

- 9) Lift and remove the top cover.

8-2-11-4 Control Console Top Cover Installation Procedure (Upper Section)

- 1) Raise the control console to its *maximum* height.
- 2) Return the top cover to its original position and fasten it with six of its eight screws using a short screw driver. The remaining two screws are located next to the location of the AC/VGA connectors box, and can be accessed from the opened space at the rear of the gas spring using a long screw driver.
- 3) Mount the AC/VGA connectors box into its original position and fasten it with its two screws. These screws can be accessed from the opened space at the rear of the gas spring using a long screw driver, as shown in [Figure 8-19](#) on page 8-18.
- 4) Lift the front section of the gas spring cover from the top cover collar and fasten it with its three screws, as shown in [Figure 8-14](#) on page 8-11.
- 5) Return the rear section of the gas spring cover into its original position and fasten it with its two screws.
- 6) Install the monitor, as described in the [Vivid™ 3 Monitor 15" Replacement Procedure \(Samsung; P/N 2336022-2\)](#) on page 8 - 27.
- 7) Plug the AC cable and VGA cable to the rear of the control console, as shown in [Figure 8-18](#) on page 8-17.
- 8) Return all peripherals to their original locations.

8-2-12 Right and Left Probe Holders Replacement Procedure

8-2-12-1 Tools

Use the appropriate Phillips-type screw drivers and an 8mm wrench, to replace the *right* and *left* probe holders.

8-2-12-2 Preparation

Shut down the Vivid™ 3 ultrasound unit, as described in [Chapter 3 - Installation](#).

8-2-12-3 Right and Left Probe Holders Removal Procedure

- 1) Remove the bottom keyboard cover, as described in the [Bottom Keyboard Cover Removal Procedure](#) on page 8 - 14.
- 2) Remove the two 8mm securing nuts (located below the keyboard) that fasten each of the probe holders to the metal frame, as shown below:



Figure 8-24 Probe Holder Nuts

- 3) Remove the probe holders.

8-2-12-4 Right and Left Probe Holders Installation Procedure

- 1) Return the probe holders to their original position on either side of the keyboard.
- 2) Fasten each probe holder beneath the keyboard with its two 8 mm securing nuts.
- 3) Return the bottom keyboard cover to its original position, as described in the [Bottom Keyboard Cover Installation Procedure](#) on page 8 - 15.

8-2-13 Front Handle Replacement Procedure

8-2-13-1 Tools

Use the appropriate Phillips-type screw drivers and an 8mm wrench, to replace the *right* and *left* probe holders.

8-2-13-2 Preparation

Shut down the Vivid™ 3 ultrasound unit, as described in [Chapter 3 - Installation](#).

8-2-13-3 Front Handle Removal Procedure

- 1) Remove the bottom keyboard cover, as described in the [Bottom Keyboard Cover Removal Procedure](#) on page 8 - 14.
- 2) Remove the two 8mm securing nuts (located below the keyboard) that fasten each of the probe holders to the metal frame - refer to [Figure 8-24](#) on page 8-23.
- 3) Remove the probe holders.

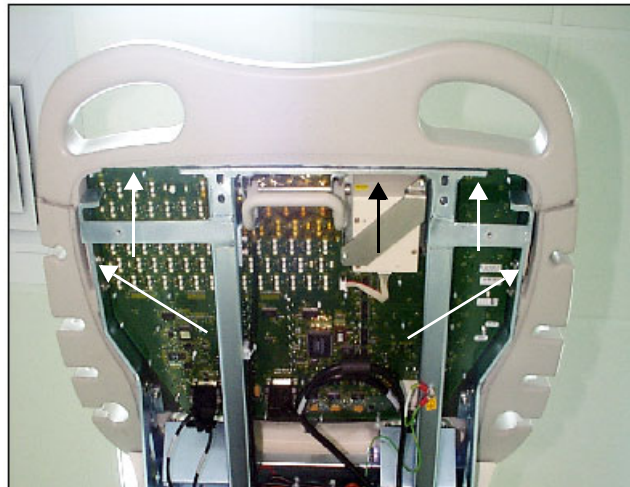

Figure 8-25 Front Handle Securing Nuts

- 4.) Remove the five 8mm securing nuts (located below the keyboard) that fasten Front Handle to the metal frame, as shown in [Figure 8-25](#), above.
- 5) Remove the Front Handle.

8-2-13-4 Front Handle Installation Procedure

- 1) Return the Front Handle to its original position on the front of the machine.
- 2) Fasten each side of the Front Handle beneath the keyboard with its 8 mm securing nuts (five in total), as seen in [Figure 8-25](#), above.
- 3) Return the probe holders to their original position on either side of the keyboard.
- 4) Fasten each probe holder beneath the keyboard with the two (8 mm) securing nuts, shown in [Figure 8-24](#) on page 8-23.
- 5) Return the bottom keyboard cover to its original position, as described in the [Bottom Keyboard Cover Installation Procedure](#) on page 8 - 15.

8-2-14 Rear Handle Replacement Procedure

NOTE: This procedure describes the replacement procedure for the Vivid 3 Rear Handle (P/N 225392-5)

8-2-14-1 Tools

Use the appropriate Phillips-type screw drivers and a combination wrench, as described in the procedures below.

8-2-14-2 Preparation

Shut down the Vivid™ 3 ultrasound unit, as described in [Chapter 3 - Installation](#).

8-2-14-3 Rear Handle Removal Procedure

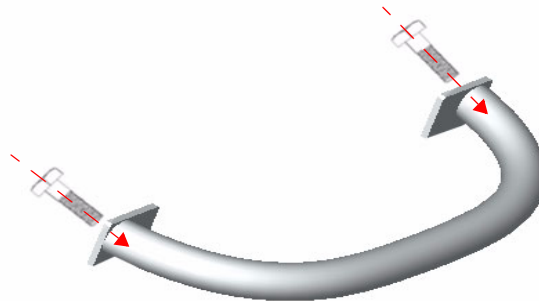

Figure 8-26 Vivid 3 Rear Handle

- 1.) Carefully remove the monitor, as described in the [Vivid™ 3 Monitor 15" Removal Procedure](#) on page 8 - 28 or the [Vivid 3 17" Monitor Removal - Procedure 1](#) on page 8 - 30 (as appropriate).
- 2.) Remove the control console lower cover, as described in the [Control Console Bottom Cover \(Upper Section\) Removal Procedure](#) on page 8 - 17.
- 3.) Remove the six screws from the metal service cover on the base assembly and remove the cover.
- 4.) Push the VGA connector slightly to allow the control console bottom cover (lower section) to slide down sufficiently to expose the rear handle securing screws (see [Figure 8-27](#) below).
- 5.) Using a combination wrench, loosen and remove the two hexagon-head screws (one on each side) that secure the rear handle to the upper console cover, as shown in [Figure 8-27](#).
- 6.) Remove the Rear Handle.



Figure 8-27 Rear Handle Securing Screws

8-2-14-4 Rear Handle Installation Procedure

- 1) Return the Rear Handle to its original position on the rear of the control console.
- 2) Fasten each side of the Rear Handle to the rear of the upper console with the two hexagon-head screws previously removed (one on each side). Use a combination wrench to tighten the handle firmly in position (do not over-tighten the screws).
- 3.) Slide the control console bottom cover (lower section) *upwards* until back in the correct position
- 4.) Return the six screws previously removed from the metal service cover on the base assembly and fasten the cover firmly in position.
- 5.) Return the control console lower cover to its original position, as described in the [Control Console Bottom Cover \(Upper Section\) Installation Procedure](#) on page 8 - 19.
- 6.) Reinstall the monitor on the control console, as described in the [Vivid™ 3 Monitor 15" Installation Procedure](#) on page 8 - 28 or the [Vivid™ 3 17" Monitor Installation - Procedure1](#) on page 8 - 31 (as appropriate).

Section 8-3 Control Console Components Replacement

The Vivid™ 3 Control Console comprises various components, the replacement procedures for each of which is described as follows:

- **Vivid™ 3 15" Monitor**
 Newer type: refer to [Vivid™ 3 Monitor 15" Replacement Procedure \(Samsung; P/N 2336022-2\)](#), as described below.
- **Vivid™ 3 17" Monitor** - refer to either of the following:
 Samsung type: see [Vivid™ 3 17" Monitor Replacement - Procedure 1](#) on page 8 - 30.
 Mag type: see [Vivid™ 3 17" Monitor Replacement - Procedure 2](#) on page 8 - 34.
- **Keyboard** - see [Keyboard Replacement Procedure](#) on page 8 - 37.
- **Keypad** - see [Keypad Replacement Procedure](#) on page 8 - 38.
- **Trackball** - see [Trackball Replacement Procedure](#) on page 8 - 42.
- **Speakers** - see [Speaker Replacement Procedure](#) on page 8 - 43.

8-3-1 Vivid™ 3 Monitor 15" Replacement Procedure (Samsung; P/N 2336022-2)

NOTE: This describes the procedure for replacing a Samsung (SyncMaster 591S) 15" monitor.

The Samsung 15" Monitor Assembly Kit (P/N: 2336022-2) contains the following items:

Item Part No.	Description	Quantity
2335250-2	Monitor "SAMSUNG" 15" Assy	1
2415943	Monitor "SAMSUNG" 15" Installation Instructions document	1
2306836	Monitor Base Cover	1
2269429	Pwr.Cord, Male/Female	1

NOTE: For the Samsung (SyncMaster 591S) 15" monitor operation and calibration instructions, refer to the information provided in the following sections:

- [Vivid™ 3 Samsung 15" and 17" Monitor Operation](#) on page 6 - 9.
- [Image Quality Calibration for the Vivid™ 3 15" and 17" Samsung Monitors](#) on page 6 - 12.

8-3-1-1 Tools

Use the appropriate Phillips-type screw drivers, as indicated in the Vivid™ 3 monitor 15" replacement procedures.

8-3-1-2 Preparation

Shut down the Vivid™ 3 ultrasound unit, as described in [Chapter 3 - Installation](#).

8-3-1-3 Vivid™ 3 Monitor 15" Removal Procedure

- 1.) Turn OFF the Vivid™ 3 main circuit breaker, located at the rear of the system (lower end).
- 2.) Disconnect the main AC power cable from the wall outlet.
- 3.) Unplug the VGA cable and AC power cable from the rear control console.
- 4.) Remove the four screws that fasten the plastic cover to the base assembly (two from each side). Remove the plastic cover.
- 5.) Loosen the securing screw located at the rear of the monitor base - see [Figure 8-28](#) below. Once this screw is loosened, the monitor may be fully rotated and lifted *upwards*, away from the Vivid 3 scanner.



Figure 8-28 Releasing Screw at Base of Samsung 15" Monitor

- 6.) Carefully remove the monitor by pulling it *upwards*. While pulling upwards, swiveling it slightly to the *right* and *left* will ease removal.

NOTE: *When removing the monitor, make sure that the Teflon washer remains in place on top of the monitor mounting base.*

8-3-1-4 Vivid™ 3 Monitor 15" Installation Procedure

NOTE: *Before mounting the replacement monitor into position, make sure that the Teflon washer has remained in place on top of the monitor mounting base.*

- 1.) In the upright position, carefully lift the replacement monitor and insert its pivot shaft ([Figure 8-29](#)) through the Teflon washer and into the hole on the monitor base.

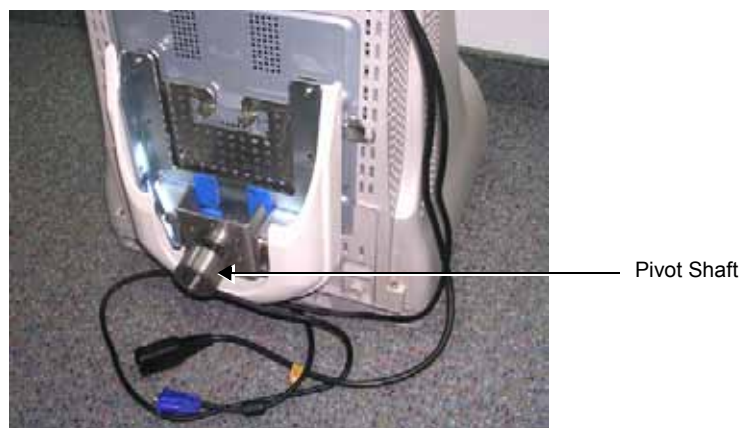

Figure 8-29 Samsung 15" Monitor - Viewed from Underside

Note: While lowering the monitor downwards, swivel it slightly to the *right* and *left* to ease insertion.

- 2.) Check that the pivot shaft is fully inserted, and that the monitor base is resting on the Teflon washer.
- 3.) Position the monitor directly in line with the front of the control console and tighten the securing screw located at the rear of the monitor base (refer to [Figure 8-28](#) on page 8-28).
- 4.) Mount the plastic cover of the base assembly back into position and secure with the four fastening screws provided (two on each side).
- 5.) Plug the VGA cable and AC power cable into the rear of the control console.
- 6.) Check that the monitor is sufficiently loose to enable swivelling slightly from *left* to *right*.
- 7.) Make sure the monitor can be tilted *up* and *down*, and that it maintains its set position.
- 8.) Adhere the appropriate Vivid™ 3 system label.
- 9.) For the next stage of the monitor installation procedure, proceed to the instructions for [Image Quality Calibration for the Vivid™ 3 15" and 17" Samsung Monitors](#) on page 6 - 12.

8-3-2 Vivid™ 3 17" Monitor Replacement - Procedure 1

NOTE: This section describes the procedure for replacing a 17" monitor based on a Samsung 17" monitor type.

With this new type of monitor ordered as a spare part, the 17" Monitor Kit (P/N: 2306835-6) will include the following items:

P/N	Description	Quantity
2306835-3	Monitor "SAMSUNG" 17" Assy	1
2337694	Monitor "SAMSUNG" 17" Rear label	1
2337700	Monitor "SAMSUNG" 17" Right Label	1
2338047	VIC Correlation Box Module	1

8-3-2-1 Tools

Use the appropriate Phillips-type screw drivers as indicated in the Vivid™ 3 monitor replacement procedures.

8-3-2-2 Preparation

Shut down the Vivid™ 3 ultrasound unit, as described in [Chapter 3 - Installation](#).

8-3-2-3 Vivid 3 17" Monitor Removal - Procedure 1

- 1.) Turn OFF the Vivid™ 3 main circuit breaker, located at the rear of the machine (lower end).
- 2.) Disconnect the main AC power cable from the wall outlet.
- 3.) Unplug the VGA cable and AC power cable from the rear control console.
- 4.) Remove the four screws that fasten the plastic cover to the base assembly (two from each side). Remove the plastic cover.
- 5.) Loosen the securing screw located at the rear of the monitor base - see [Figure 8-30](#) on page 8-30. Once this screw is loosened, the monitor may be fully rotated and lifted upwards, away from the machine.



Figure 8-30 Releasing Screw at Base of 17" Monitor

- 6.) Remove the monitor by pulling it upwards. While pulling the monitor upwards, swiveling it slightly to the *right* and *left* will ease removal.

NOTE: *When removing the monitor, make sure that the Teflon washer remains in place on top of the monitor mounting base.*

You are now ready to install a new monitor, as described in the following procedure.

8-3-2-4 Vivid™ 3 17" Monitor Installation - Procedure1

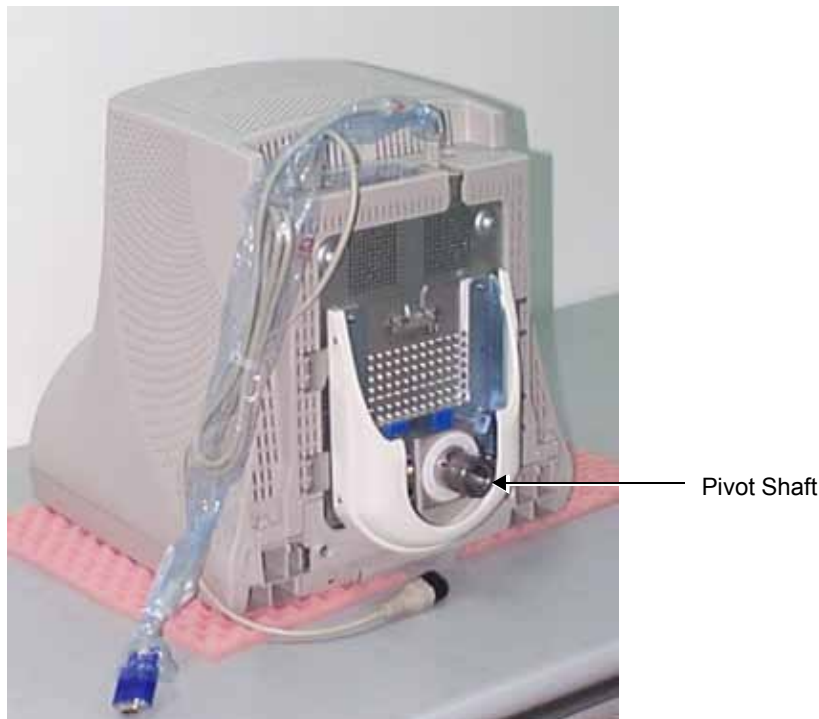

Figure 8-31 New Samsung 17" Monitor - Viewed from Underside

NOTE: *Before mounting the new monitor into position, make sure that the Teflon washer has remained in place on top of the monitor mounting base.*

- 1.) In the upright position, carefully lift the new monitor and insert its pivot shaft (see [Figure 8-31](#)) through the Teflon washer and into the hole on the monitor base.
While lowering the monitor downwards, swivel it slightly to the *right* and *left* to ease insertion.
- 2.) Check that the pivot shaft is fully inserted, and that the monitor base is resting on the Teflon washer.
- 3.) Position the monitor directly in line with the front of the control console and tighten the securing screw located at the rear of the monitor base.
- 4.) Mount the plastic cover of the base assembly back into position and secure with the four fastening screws provided (two on each side).
- 5.) Plug the VGA cable and AC power cable into the rear of the control console.
- 6.) Check that the monitor is sufficiently loose to enable swivelling slightly from *left* to *right*.
- 7.) Make sure the monitor can be tilted *up* and *down*, and that it maintains its set position.
- 8.) Adhere the appropriate Vivid™ 3 system label.

For the next stage of the new monitor installation procedure, proceed to the instructions for [Image Quality Calibration for the Vivid™ 3 15" and 17" Samsung Monitors](#) on page 6 - 12.

8-3-2-4-1 Installing a New VIC Correlation Box

NOTE: *This procedure should be performed only when installing a Samsung 17" monitor, or when replacing an existing VIC Correlation box!*

NOTE: *Before commencing this procedure, check that system has been disconnected from the mains power as described in [step 1 of Vivid 3 17" Monitor Removal - Procedure 1](#) on page 8 - 30.*

- 1.) Remove the machine's side covers see [Side Covers Removal Procedure](#) on page 8 - 4
- 2.) Unscrew and remove the two screws located on the upper BEP bracket.
- 3.) Unscrew and remove the two screws located at the top of the bracket that connects the VIC assembly to the metal frame - see [Figure 8-32](#).

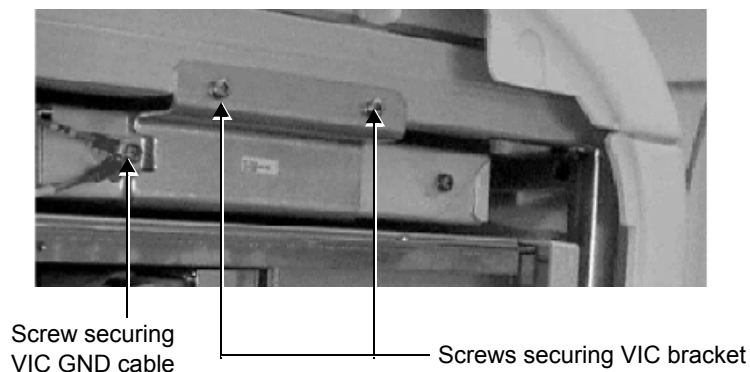

Figure 8-32 VIC Assembly

- 4.) Rotate the VIC sideways and pull out the VGA cable.
- 5.) Assemble the VIC correlation module (P/N: 2338047) and connect it to *VGA OUT* on the VIC module.
- 6.) Connect the cable (P/N: 2252964) to VIC correlation module (P/N: 2338047) and pass it through BEAM 3 energy chain (P/N: 2272900) and up into the VGA box.
- 7.) Return the VIC to its original position above the BEP - see [Figure 8-33](#).

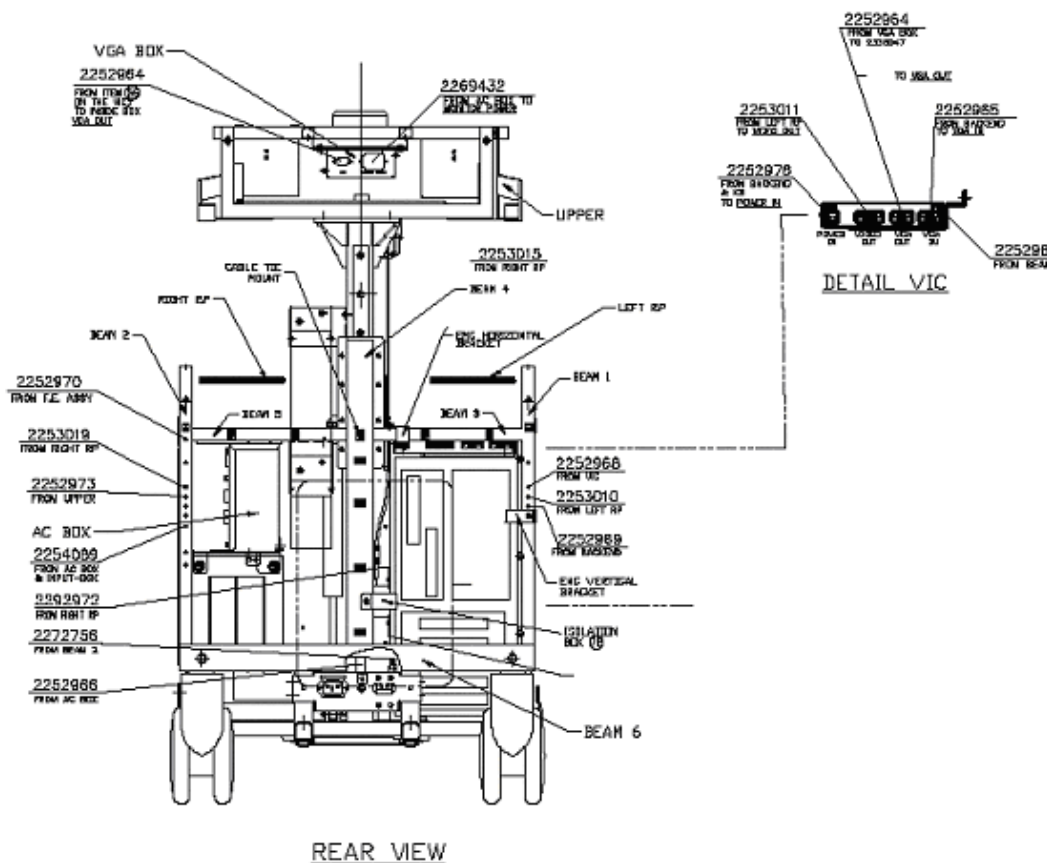

Figure 8-33 VIC Correlation Module in Position

- 8.) Fasten the VIC assembly to the metal frame, using the two screws removed in [step 3](#).
- 9.) Fasten the upper back-end BEP bracket in position, using the two screws removed in [step 2](#).
- 10.) Reassemble the side covers - see [Side Covers Installation Procedure](#) on page 8 - 4
- 11.) Check that all covers are fixed firmly in position.

For the next stage of the new monitor installation procedure, proceed to the instructions for [Image Quality Calibration for the Vivid™ 3 15" and 17" Samsung Monitors](#) on page 6 - 12.

8-3-3 Vivid™ 3 17" Monitor Replacement - Procedure 2

NOTE: This section describes the procedure for replacing a 17" monitor based on a MAG 17" monitor type.

8-3-3-1 Tools

Use the appropriate Phillips-type screw drivers as indicated in the Vivid™ 3 monitor replacement procedures.

8-3-3-2 Preparation

Shut down the Vivid™ 3 ultrasound unit, as described in [Chapter 3 - Installation](#).

8-3-3-3 Vivid™ 3 17" Monitor Removal - Procedure 2

- 1) Unplug the VGA cable and AC power cable from the rear control console.
- 2) Remove the four screws that fasten the plastic cover of the base assembly, two screws from either side. Remove the plastic cover.
- 3) Loosen the securing screw located at the rear of the monitor base. Once this screw is loose, you can fully rotate and lift the monitor out from the machine.



Figure 8-34 Vivid™ 3 Monitor Release Screw

- 4) Remove the monitor by pulling it upwards. You may need to swivel the monitor slightly *right* and *left* while pulling it upwards.

NOTE: *Ensure that the Teflon washer remains in place when you remove the monitor.*

- 5) Carefully lay the monitor on a soft surface and turn it upside down, so that its underside is accessible, as shown in [Figure 8-35](#) on page 8-35.



Figure 8-35 Vivid™ 3 Monitor showing Underside

- 6) Remove the three screws that fasten the bracket at the front of the monitor, and then remove the bracket.
- 7) Remove the screw located on the left of the VGA cable at the back of the monitor.
- 8) Remove the two remaining screws from the back of the monitor. This will release the space bar located between the back of the monitor and the monitor base assembly.
- 9) Remove the two screws securing the base assembly to the monitor, located one on either side of the bottom front of the monitor.
- 10) Push the base assembly towards the rear of the monitor until its hinges are released from the monitor's case to release the base assembly, which can then be removed, as shown below:

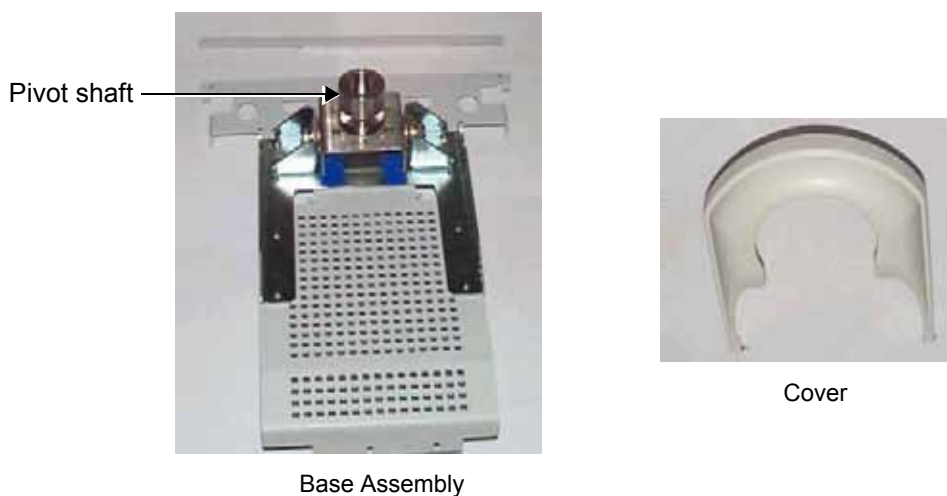

Figure 8-36 Vivid™ 3 Base Assembly and Cover

8-3-3-4 Vivid™ 3 17" Monitor Installation - Procedure 2

- 1) Carefully lay the monitor on a soft surface and turn it upside down, so that its bottom is accessible.
- 2) Place the base assembly on the bottom of the monitor's case.
- 3) Push the base assembly towards the front of the monitor while ensuring that its hinges are inserted into their slots on the monitor case.
- 4) Insert the space bar between the back of the monitor and the monitor base assembly, and then fasten it loosely with its two screws. Do not tighten the screws.
- 5) Fasten the base assembly with its two screws, one on each side of the bottom front of the monitor.
- 6) Correct the positioning of the space bar and tighten it with its two screws.
- 7) Fasten the base assembly with the screw located to the left of the VGA cable at the back of the monitor.
- 8) Mount the bracket at the front of the monitor case with its three screws.

Note: *Ensure that the Teflon washer is in place before you return the monitor to the control console.*

- 9) Carefully lift the monitor and insert its pivot shaft through the Teflon washer into the hole on the top of the control console. You may need to swivel the monitor slightly *right* and *left* while pushing it downwards. Check that the pivot shaft of the monitor base is fully inserted, and that the base is resting on the Teflon washer.
- 10) Position the monitor directly in line with the front of the control console and tighten the securing screw located at the rear of the monitor base.
- 11) Mount the plastic cover of the base assembly back in position with its four screws, two on either side.
- 12) Plug the VGA cable and AC power cable into the rear of the control console.
- 13) Check that the monitor can turn to the *left* and *right* to a limited degree. Also check that it can be tilted *upwards* and *downwards*, and that it holds its set position.

8-3-4 Keyboard Replacement Procedure

8-3-4-1 Tools

Use the appropriate flat and Phillips-type screw drivers, a wire cutter and the appropriate Hex wrench keys as indicated in the keyboard replacement procedure.

8-3-4-2 Preparation

Shut down the Vivid™ 3 ultrasound unit, as described in [Chapter 3 - Installation](#).

8-3-4-3 Keyboard Removal Procedure

- 1) Remove the bottom keyboard cover and cable hooks, as described in the [Bottom Keyboard Cover Removal Procedure](#) on page 8 - 14.
- 2) Unplug the three keyboard cables located at the bottom of the keyboard.
- 3) Remove the speaker covers, as described in the [Speaker Cover Removal Procedure](#) on page 8 - 16.
- 4) Remove the two nuts securing the probe holders to the keyboard, located beneath the keyboard on either side, and then remove the probe holders.
- 5) Remove the two M4 nuts securing the keyboard to the metal frame, located one on either corner of the far end of the keyboard.
- 6) Loosen the three M5 nuts and two M5 side screws securing the front handle and pull the front handle backwards to free the front edge of the keyboard.
- 7) Lift out the keyboard.

8-3-4-4 Keyboard Installation Procedure

- 1) Return the keyboard to its original position.
- 2) Push the keyboard as far in as it can go, and then fasten it to the metal frame from underneath at its far end corners with the two M4 nuts, one on either corner.
- 3) Push the front handle forwards to its original position so that it overlaps the front edge of the keyboard, and then fasten it to the metal frame with the three M5 nuts and the two M5 side screws.
- 4) Return the two probe holders to their positions on either side of the keyboard and fasten each with two nuts to the metal frame. Before tightening the nuts adjust each probe holder to fit properly and symmetrically on the sides of the keyboard.
- 5) Return the speakers cover to its original position, as described in the [Speaker Cover Installation Procedure](#) on page 8 - 16. Before tightening the screws, adjust the cover to fit properly and symmetrically.
- 6) Plug in the three keyboard cables, located at the bottom of the keyboard.
- 7) Return the bottom keyboard cover and cable hooks to their original location, as described in the [Bottom Keyboard Cover Installation Procedure](#) on page 8 - 15.

8-3-5 Keypad Replacement Procedure

8-3-5-1 Tools

Use a small flat screw driver, as indicated in the keypad replacement procedure.

8-3-5-2 Preparation

Shut down the Vivid™ 3 ultrasound unit, as described in [Chapter 3 - Installation](#).

8-3-5-3 Keypad Removal Procedure

- 1) Carefully place a small flat screw driver between the keypad you wish to remove and its neighboring keypad - see [Figure 8-37](#) below.
- 2) Use the screw driver to gently lever off the defective keypad, until it is completely loosened from its base.
- 3.) Lift off and remove the defective keypad.

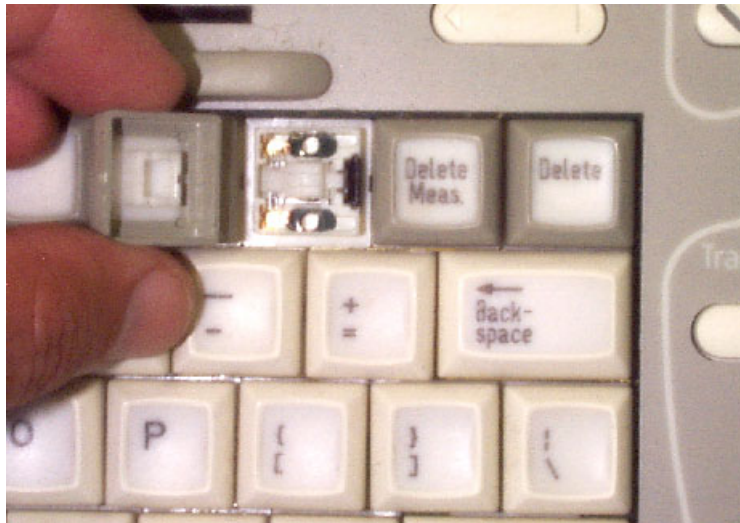

Figure 8-37 Keypad Replacement

NOTE: For Key Pad Part Numbers, refer to [Table 9-8 on page 9-19](#).

8-3-5-4 Keypad Installation Procedure

- 1) Carefully place a new keypad into position on the keyboard, taking care to align the two notches on the base of the pad with those on the securing base plate.

NOTE: The notches must be vertically aligned with the base, otherwise the keypad will not sit at the correct height on the keyboard.

- 2) Gently push the keypad down until it snaps into position.

8-3-6 Keycaps (External Keyboard) Replacement Procedure

NOTE: This section describes the replacement procedure for ATGC slider Keycaps on the external keyboard.

NOTE: ATGC Slider Keycaps are supplied in a Keycap Kit - for details of the Part Number, refer to [Table 9-8](#) on page 9-19.

NOTE:

8-3-6-1 Tools

Use a small flat screw driver, as indicated in the keycaps replacement procedure.

8-3-6-2 Preparation

Shut down the Vivid™ 3 ultrasound unit, as described in [Chapter 3 - Installation](#).

8-3-6-3 Keycaps Removal Procedure

- 1) Carefully place a small flat screw driver between the ATGC slider keycap you wish to remove and the surface of the keyboard.
- 2) Use the screw driver to gently lever off the defective keycap, until it is completely loosened from its base.
- 3.) Lift off and remove the defective keycap - see [Figure 8-37](#) below.



Figure 8-38 ATGC Slider Keycap Replacement

8-3-6-4 Keycap Installation Procedure

- 1) Carefully place a new keycap into position on the securing pin, taking care to align the notches on the base of the keycap with those on the securing pin.

NOTE: The notches must be aligned correctly, otherwise the keycap will not sit at the correct height on the external keyboard.

- 2) Gently push the keycap down until it snaps into position.

8-3-7 Rotary Knob (External Keyboard) Replacement Procedure

NOTE: This section describes the replacement procedure for a parameter adjustment Rotary Knob on the external keyboard.

NOTE: Rotary knobs are supplied as part of the Keycap Kit - for details of the Part Number, refer to [Table 9-8](#) on page 9-19.

NOTE:

8-3-7-1 Tools

Use a small flat screw driver, as indicated in the rotary knob replacement procedure.

8-3-7-2 Preparation

Shut down the Vivid™ 3 ultrasound unit, as described in [Chapter 3 - Installation](#).

8-3-7-3 Rotary Knob Removal Procedure

- 1) Carefully place a small flat screw driver between the rotary knob you wish to remove and the surface of the keyboard - see [Figure 8-37](#) below.
- 2) Use the screw driver to gently lever off the defective rotary knob, until it is completely loosened from its base.
- 3.) Lift off and remove the defective knob - see [Figure 8-39](#) below.



Figure 8-39 Rotary Knob Replacement

- 4.) Carefully take out the metal tension plate from the centre of the knob (refer to [Figure 8-40](#) on page 8-41), before discarding the defective knob. **Do not discard the tension plate.**

8-3-7-4 Rotary Knob Installation Procedure

- 1) Using a new rotary knob, insert the metal tension plate (removed in [step 4](#) above) into the centre of the knob, aligning the plate correctly with the notches on each side of the hole. The plate, which is slightly curved (to provide tension), should be positioned with the curved surface facing towards the center of the hole, as shown in [Figure 8-40](#) below.

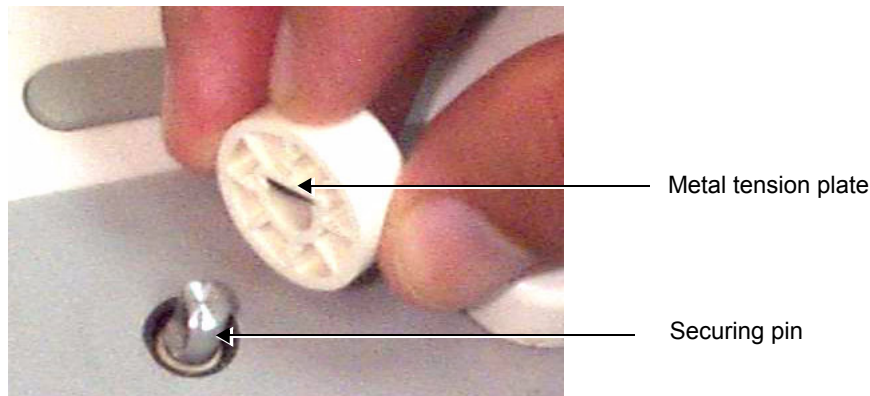

Figure 8-40 Tension Plate Fitted in Centre of Knob

- 2) Carefully place the new rotary knob into position on the securing pin, taking care that the tension plate remains in position inside the knob, while aligning the core of the knob base with the flat-sided notch on the securing pin - see [Figure 8-40](#), above.

NOTE: *The notch must be aligned correctly, otherwise the rotary knob will not sit at the correct height on the external keyboard.*

- 3.) Gently push the rotary knob down until it snaps into position.

8-3-8 Trackball Replacement Procedure

8-3-8-1 Tools

Use the appropriate flat and Phillips-type screw drivers, a wire cutter and the appropriate Hex wrench keys as indicated in the trackball replacement procedure.

8-3-8-2 Preparation

Shut down the Vivid™ 3 ultrasound unit, as described in [Chapter 3 - Installation](#).

8-3-8-3 Trackball Removal Procedure

- 1) Remove the bottom keyboard cover, as described in the [Bottom Keyboard Cover Installation Procedure](#) on page 8 - 15.
- 2) Disconnect the trackball cable from the trackball unit - see [Figure 8-41](#) below.

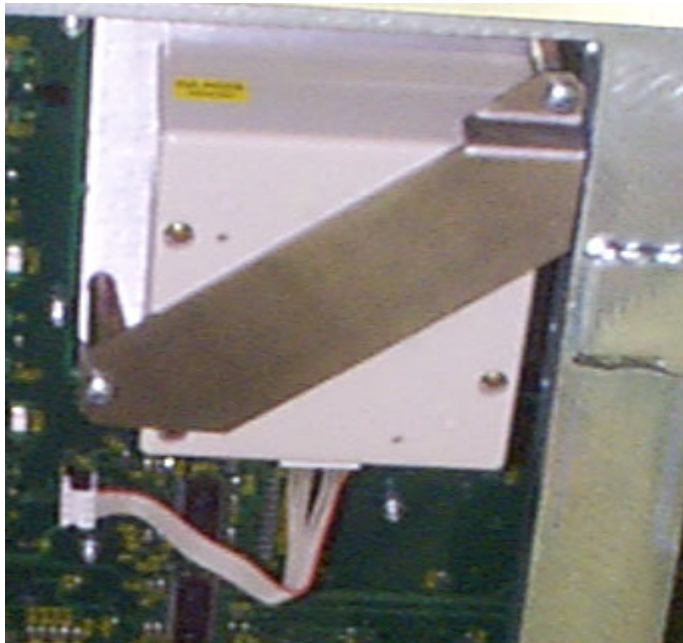

Figure 8-41 Trackball Removal

- 3) Remove the two screws located on the bracket on either side of the trackball unit, and then remove the trackball unit.

8-3-8-4 Trackball Installation Procedure

- 1) Return the trackball unit to its original location and insert the two screws located on the bracket on either side of the trackball unit.
- 2) Connect the trackball cable to the trackball unit.
- 3) Return the bottom keyboard cover to its original location, as described in the [Bottom Keyboard Cover Installation Procedure](#) on page 8 - 15.

8-3-9 Speaker Replacement Procedure

8-3-9-1 Tools

Use the appropriate flat and Phillips-type screw drivers, a wire cutter and the appropriate Hex wrench keys as indicated in the speaker replacement procedure.

8-3-9-2 Preparation

Shut down the Vivid™ 3 ultrasound unit, as described in [Chapter 3 - Installation](#).

8-3-9-3 Speaker Removal Procedure

- 1) Remove the bottom keyboard cover, as described in the [Bottom Keyboard Cover Removal Procedure](#) on page 8 - 14.
- 2) Remove the speaker cover, as described in the [Speaker Cover Removal Procedure](#) on page 8 - 16.
- 3) Remove the four speaker screws, one from each corner of both of the speakers.
- 4) Gently pull the speakers towards you.
- 5) Disconnect the wires at the back of the speakers.

8-3-9-4 Speaker Installation Procedure

- 1) Reconnect the wires to the back of the new speakers.
- 2) Return the speakers to their original position, ensuring that the two connection legs of each speaker are facing the two connection legs of the opposite speaker, otherwise an electrical short may occur.
- 3) Fasten each speaker with the four screws at its corners.
- 4) Return the speaker cover to its original position, as described in the [Speaker Cover Installation Procedure](#) on page 8 - 16.
- 5) Return the bottom keyboard cover to its original position, as described in the [Bottom Keyboard Cover Installation Procedure](#) on page 8 - 15.

Section 8-4 Front End Parts Replacement

8-4-1 Front End Boards Replacement Procedure

NOTE: The procedures below provide the instructions for replacing the following boards:
FB, MUX, BF, FEC, RFT or IMP.

8-4-1-1 Tools

Use the appropriate flat and Phillips-type screw drivers and an ESD wrist band strap as indicated in the front end boards replacement procedures.



CAUTION: DO NOT TOUCH ANY BOARDS WITH INTEGRATED CIRCUITS PRIOR TO TAKING THE NECESSARY ESD PRECAUTIONS:



1.ALWAYS CONNECT YOURSELF, VIA AN ARM-WRIST STRAP, TO THE ADVISED ESD CONNECTION POINT LOCATED ON THE REAR OF THE SCANNER (TO THE RIGHT OF THE POWER CONNECTOR).

2.FOLLOW GENERAL GUIDELINES FOR HANDLING OF ELECTROSTATIC SENSITIVE EQUIPMENT.

8-4-1-2 Preparation

Shut down the Vivid™ 3 ultrasound unit, as described in [Chapter 3 - Installation](#).

8-4-1-3 Front End Boards Removal Procedure



CAUTION: FRONT END BOARDS ARE HEAVY!



FAILURE TO TAKE PRECAUTIONS WHEN LIFTING , COULD RESULT IN PERSONAL INJURY AND/OR DAMAGE TO THE SYSTEM.

- 1) Remove the *left* side cover, as described in the [Side Covers Removal Procedure](#) on page 8 - 4.
- 2) Remove the front door of the crate by unscrewing the two large screws at the top of the door, and gently pulling the door down and lifting it off its hinges.
- 3) Release the plastic latches located at the top and the bottom of each card (board) - see [Figure 8-42](#).

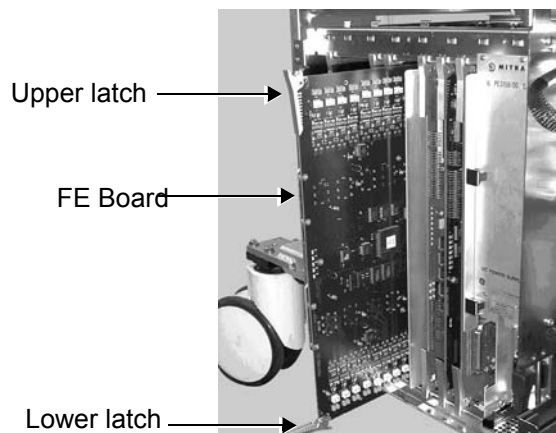

Figure 8-42 Front End Boards

- 4) Gently pull the required card from the crate.



CAUTION: When removing the card, ESD may cause damage to the card. Always have the ESD hand strip connected to the machine chassis and to your hand.

8-4-1-4 Front End Boards Installation Procedure

- 1) Gently slide and push the required card to its original location, using the metal frame guiding tracks.
- 2) Use the plastic latches to firmly lock in the card in position, so that the connectors are firmly placed in their sockets.
- 3) Return the front door of the crate to its original position and tighten the two screws that secure the door in place.
- 4) Return the left side cover to its original position, as described in the [Side Covers Installation Procedure](#) on page 8 - 4.

Note: When you insert a Front End Board into the crate, ensure that the probe connector's metal frame slides into its tracks.

Note: The [Beamformer Calibration](#) procedure must be performed each time a Beamformer is replaced. Refer to the instructions on page 6-17

8-4-2 TR4 Boards Replacement Procedure

NOTE: The procedure below provides the instructions for replacing any of the TR4 boards (P/N 2253036).

8-4-2-1 Tools

Use the appropriate flat and Phillips-type screw drivers and an ESD wrist band strap as indicated in the TR4 Boards replacement procedure.



CAUTION: DO NOT TOUCH ANY BOARDS WITH INTEGRATED CIRCUITS PRIOR TO TAKING THE NECESSARY ESD PRECAUTIONS:



1.ALWAYS CONNECT YOURSELF, VIA AN ARM-WRIST STRAP, TO THE ADVISED ESD CONNECTION POINT LOCATED ON THE REAR OF THE SCANNER (TO THE RIGHT OF THE POWER CONNECTOR).

2.FOLLOW GENERAL GUIDELINES FOR HANDLING OF ELECTROSTATIC SENSITIVE EQUIPMENT.

8-4-2-2 Preparation

Shut down the Vivid™ 3 ultrasound unit, as described in [Chapter 3 - Installation](#).

8-4-2-3 TR4 Boards Removal Procedure

1) Remove the FE Board, as described in the [Front End Boards Removal Procedure](#) on page 8 - 44.



CAUTION: FRONT END BOARDS ARE HEAVY!



FAILURE TO TAKE PRECAUTIONS WHEN LIFTING , COULD RESULT IN PERSONAL INJURY AND/OR DAMAGE TO THE SYSTEM.

2.) Place the FE Board on a desk or a stable surface, on top of an ESD mat.

3.) Remove each of the four screws (two from each side) that hold the two brackets that secure the TR4 boards to the FE Board main plate, as shown in [Figure 8-43](#) below.

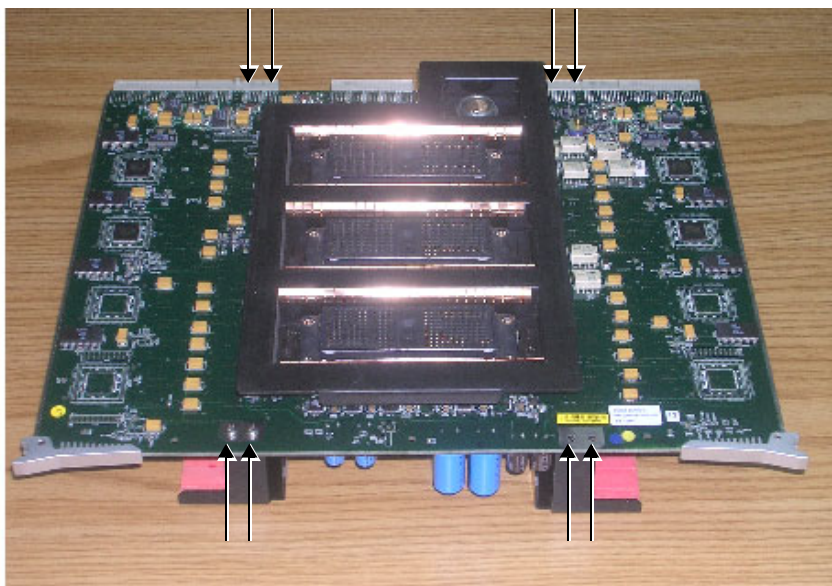

Figure 8-43 Location of Screws on Securing Brackets

- 4.) Turn the FE Board over, then remove the brackets that secure the TR4 boards in place as shown in [Figure 8-44](#) below.

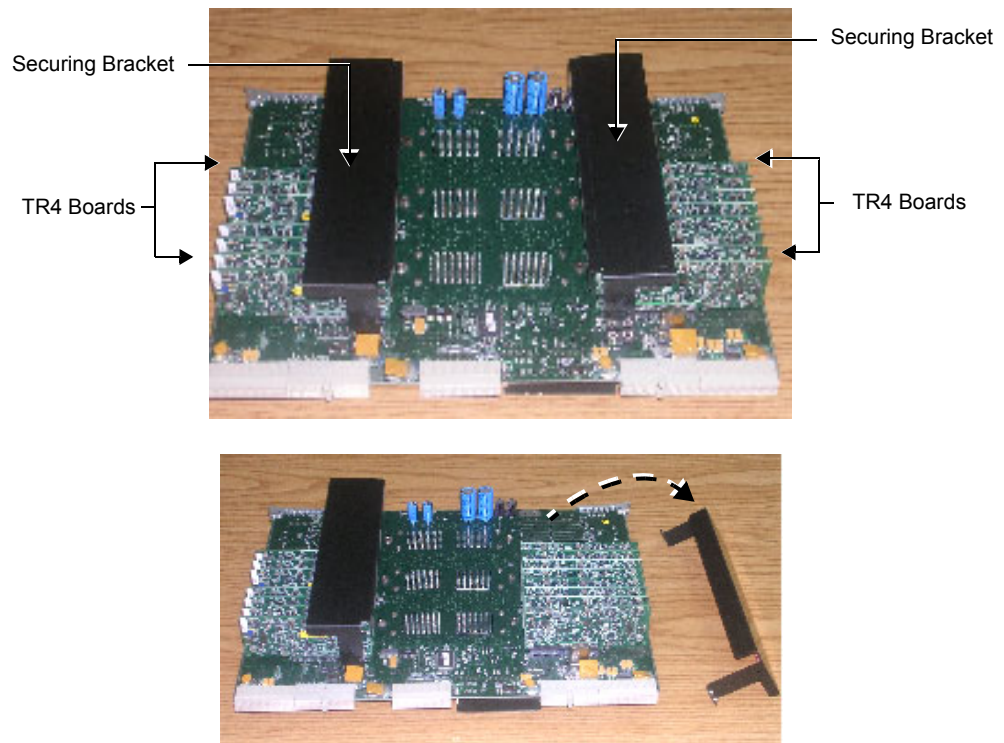

Figure 8-44 Removing the Securing Brackets

- 5.) Carefully pull *upwards* and gently remove the suspected faulty TR4 board.

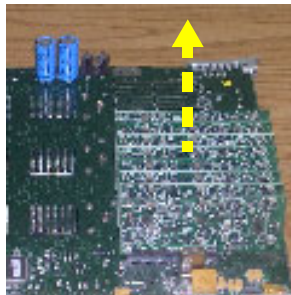

Figure 8-45 Removing the TR4 Board

8-4-2-4 TR4 Boards Installation Procedure

- 1.) Carefully insert the new TR4 board in position on the FE Board, making sure it is plugged firmly in place.
- 2.) Return the bracket (previously removed) that secures the TR4 boards to its original location above the TR4 boards.
- 3.) Return and tighten the four screws (two on each side) to fasten the bracket in position and secure the TR4 boards to the Front board main plate - refer to [Figure 8-43](#) on page 8-46.
- 4.) Carefully return the FE Board to its original position in the FE crate, as described in the [Front End Boards Installation Procedure](#) on page 8 - 45.

NOTE: When you insert a Front End Board into the crate, ensure that the probe connector's metal frame slides into its tracks.

8-4-3 DC Power Supply Replacement Procedure

8-4-3-1 Tools

Use the appropriate flat and Phillips-type screw drivers and a wire cutter, as indicated in the DC power supply replacement procedure.

8-4-3-2 Preparation

Shut down the Vivid™ 3 ultrasound unit, as described in [Chapter 3 - Installation](#).

8-4-3-3 DC Power Supply Removal Procedure

- 1) Disconnect the PCI cable from the Image Port Board.
- 2) Release the securing clip and disconnect the AC power supply cable from the bottom of the DC power supply.
- 3) Disconnect the AC power supply cable that is connected to the Tx P.S (HV P.S.).
- 4) Remove the four small screws located one at each corner of the front panel of the power supply.
- 5) Remove the DC power supply by pulling it out using its handle on the front panel.

8-4-3-4 DC Power Supply Installation Procedure

- 1) Return the DC power supply to its original position.
- 2) Fasten the front panel of the power supply with its four small screws, one at each corner.
- 3) Reconnect the AC power cable to the Tx P.S.
- 4) Reconnect the AC power cable to the bottom of the DC power supply, and secure it with the clip.
- 5) Reconnect the PCI cable to the Image Port Board.

8-4-4 TX Power Supply Replacement Procedure

8-4-4-1 Tools

Use the appropriate flat and Phillips-type screw drivers, a wire cutter, and the appropriate Hex wrenches as indicated in the Tx power supply replacement procedure.

8-4-4-2 Preparation

Shut down the Vivid™ 3 ultrasound unit, as described in [Chapter 3 - Installation](#).

8-4-4-3 TX Power Supply Removal Procedure

- 1) Remove the *right* cover, as described in the [Side Covers Removal Procedure](#) on page 8 - 4.
- 2) Remove the DC power supply - refer to the [DC Power Supply Removal Procedure](#) on page 8 - 48.
- 3) Remove the two screws located at the top of the Tx power supply unit.
- 4) Remove the Tx power supply unit by pulling it out by the handle on the front panel.

8-4-4-4 TX Power Supply Installation Procedure

- 1) Return the Tx power supply unit to its original position.
- 2) Fasten the Tx power supply unit with the two screws at its top.
- 3) Install the DC power supply, as described in the [DC Power Supply Installation Procedure](#) on page 8 - 48.
- 4) Reconnect the Tx power supply input cable.

- 5) Return the right side cover to its original position, as described in the [Side Covers Installation Procedure](#) on page 8 - 4.

Note: When you install the Tx power supply unit, ensure that it slides into its guiding tracks.

8-4-5 Front End Crate Replacement Procedure

8-4-5-1 Tools

Use the appropriate flat and Phillips-type screw drivers, a wire cutter and the appropriate Hex wrenches as indicated in the front end crate replacement procedure.

8-4-5-2 Preparation

Shut down the Vivid™ 3 ultrasound unit, as described in [Chapter 3 - Installation](#).

8-4-5-3 Front End Crate Removal Procedure



CAUTION: Support the crate while removing it. The crate is heavy, weighing approximately 16 Kg (35.2 lbs).

- 1) Pull out and remove the air filter from the front of the machine.
- 2) Disconnect all probes from the probe sockets.
- 3) Remove the *right* side cover, as described in the [Side Covers Removal Procedure](#) on page 8 - 4.
- 4) Remove the front door of the crate by unscrewing the two large screws at the top of the door, and gently pulling the door down and lifting it off its hinges.
- 5) Disconnect the AC power cable from the DC power supply.
- 6) Loosen the two wing nuts of the PCI flat cable spring clamp (located on the right wall of the crate) and release the cable from the wall.
- 7) Slide out the Image Port board and unplug the PCI cable from the board.
- 8) Remove the eight screws that secure the front end crate to the frame then gently slide the crate out towards you.
- 9) Disconnect the fan power cable, located on the upper part of the outside wall of the front end crate, as shown below:

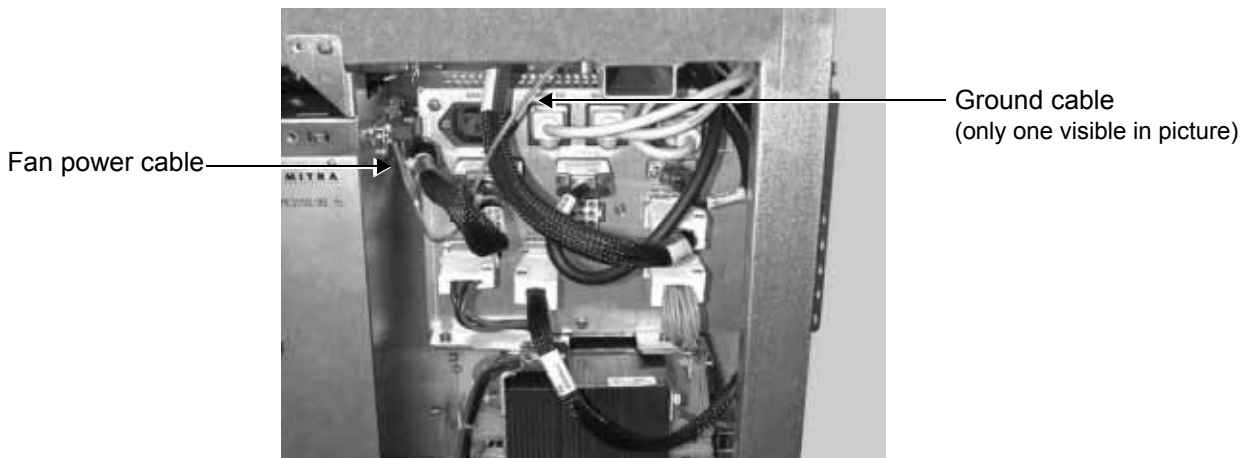

Figure 8-46 Fan Power Cable Connections

- 10) Disconnect the two Ground cables from the crate - see [Figure 8-46](#) on page 8-50.
- 11) Carefully remove the front end crate.



CAUTION: To avoid damaging the Ground cables, pull the crate out very slowly.

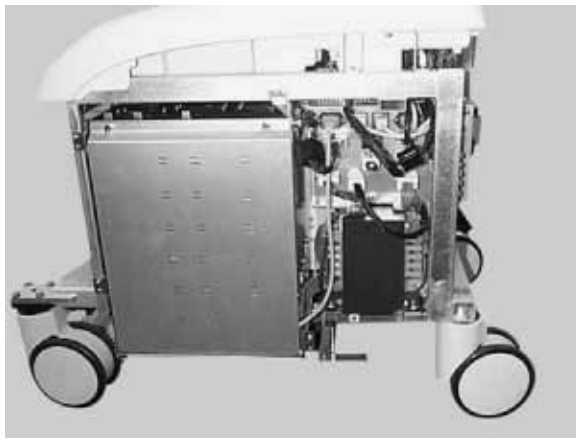

Figure 8-47 Front End Crate

8-4-5-4 Front End Crate Installation Procedure

- 1) Return the front end crate, but do not slide it to its final position.
- 2) Reconnect the two Ground cables to their original position on the front end crate.
- 3) Reconnect the front end fan power cable, located on the upper part of the outside wall of the front end crate.
- 4) Gently slide the front end crate back to its original position.
- 5) Fasten the front end crate to the frame with the eight screws.
- 6) Reconnect the PCI cable to the Image Port Board and slide it back to its original slot in the crate.
- 7) Mount the PCI flat cable under the spring clamp, and then tighten the two winding nuts to secure the cable to the right wall of the crate.
- 8) Reconnect the AC power cable to the DC power supply.
- 9) Return the front door of the crate and tighten the two screws that secure the door in place.
- 10) Return the left side cover to its original position, as described in the [Side Covers Installation Procedure](#) on page 8 - 4.
- 11) Ensure that the filter is clean, and then return it to its original position.

Note: Refer to [Chapter 10 - Periodic Maintenance](#) for filter cleaning procedures.

- 12) Reconnect the probes.

8-4-6 Fan Replacement Procedure

8-4-6-1 Tools

Use the appropriate flat and Phillips-type screw drivers, a wire cutter and the appropriate Hex wrenches as indicated in the fan replacement procedure.

8-4-6-2 Preparation

Shut down the Vivid™ 3 ultrasound unit, as described in [Chapter 3 - Installation](#).

8-4-6-3 Fan Removal Procedure

- 1) Remove the front end crate, as described in the [Front End Crate Removal Procedure](#) on page 8 - 50.
- 2) Unscrew and remove the four screws that secure the fans to the top of the front end crate.



Figure 8-48 Fan Screws

Note: Mark the position at which the fan is attached to the connector, to ensure that the new fan is reconnected correctly.

- 3) Gently lift up the fan and disconnect its wires from the block terminal.
- 4) Unwrap the spiral wrapping around the harness and release the fan wires.
- 5) Remove the fan, together with its four Isodamp Grommets and Insulation Sleeves found under each corner.

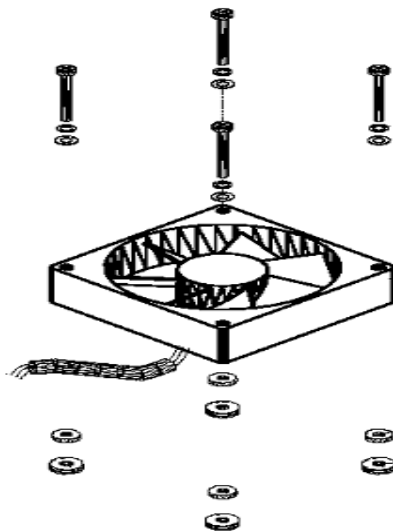

Figure 8-49 Fan Part Details

8-4-6-4 Fan Installation Procedure

- 1) Wrap the spiral wrapping to hold the fan wires together.
- 2) Reconnect the fan wires to the block terminal using the same color coding as the fan that was removed.
- 3) Mount each fan with four Isodamp Grommets and Insulation Sleeves underneath the top of the crate, as shown in [Figure 8-49](#) on page 8-52.



CAUTION: Ensure that you position the fan in the correct airflow direction (pushing air inwards into the crate) and that you connect the fan to the connector that was marked during the removal process.

- 4) Apply Loctite 24L[®] on each of the screw tips, then insert them with their appropriate spring washers and flat washers in the fan holes.
- 5) Tighten the screws to the point where the rubber Isodamp grommets stays a little flexible to absorb the vibrations of the fans, in order to reduce any noise they may cause.
- 6) Install the front end crate, as described in the [Front End Crate Installation Procedure](#) on page 8 - 51.

Section 8-5 Back End Parts Replacement

Replacement of internal Back End Processor components should be done by qualified personnel *only*.

When replacing internal BEP components, ensure replacement is with new components of the same *type*, and hardware version and place them in the PCI slots as shown in the appropriate figure below.

Refer to [Figure 8-50](#) or [Figure 8-51](#), as appropriate.



CAUTION: *Failure to follow this exact instruction will cause irreversible damage!*

8-5-1

Preparation

Furnished Materials

Confirm that the Back End Processor Kit (P/N: 2315842-7) contains the following items:

P/N	Description	Quantity
2406742	Backend (BEP) Assembly	1
2330026	BEP Front Panel for MOD	1
2344553	BEP Front Panel Basic	1
2344630	BEP Upper bracket	1
2343032	MO Drive Track	2
2399332	BEP Installation Instructions.	1
2347549-3	CD with SW VER 2.3.11	1
2419774	CD VGA Upgrade Patch	1
2413447	CD Patch 2.3.12	1
2413448	CDRW Patch	1
2400730	CD Probe Overheating Protection Patch	1
2418083	CD with SW VER 3.3	1
2418084	CD with SW VER 4.3	1
2418086	CD with SW VER 3.6	1
2418087	CD with SW VER 4.6	1
2366934	Help Files CD	1
2412393	CD Pouch Assy	1

Important: The BEP arrives inside packing box P/N 2328455. Make sure the returned BEP is shipped for return in the same packing box.

NOTE: *IMPORTANT - When replacing the BEP, the new Back End Processor will be supplied in a basic configuration with only the following components ready installed:*

- CD-R driver
- Floppy driver
- HD driver
- Cables and Brackets
- Memory 512 MB

Therefore, the FE will need to remove some components from the removed BEP and install them in the new BEP (as part of the BEP Installation procedure - described below).

In addition, for BEP0 and BEP1 systems (only), it will be necessary to order certain additional parts in advance. These are listed in [Table 8-3](#) below (and also described in the BEP Installation procedure).

Table 8-3 Additional Parts to be Ordered

BEP	P/N	Description	Quantity
BEP0	2340279	PC VIC Assembly	1
	2253027-5	PCB: Keyboard Ctrl. Card	1
	FB200973	PCB: PC2IP (required if existing board earlier than Rev C)	1
	2256476	ECG Patient I/O Module	1
BEP1	2340279	PC VIC Assembly	1
	FB200973	PCB: PC2IP (required if existing board earlier than Rev C)	1
	2256476	ECG Patient I/O Module	1

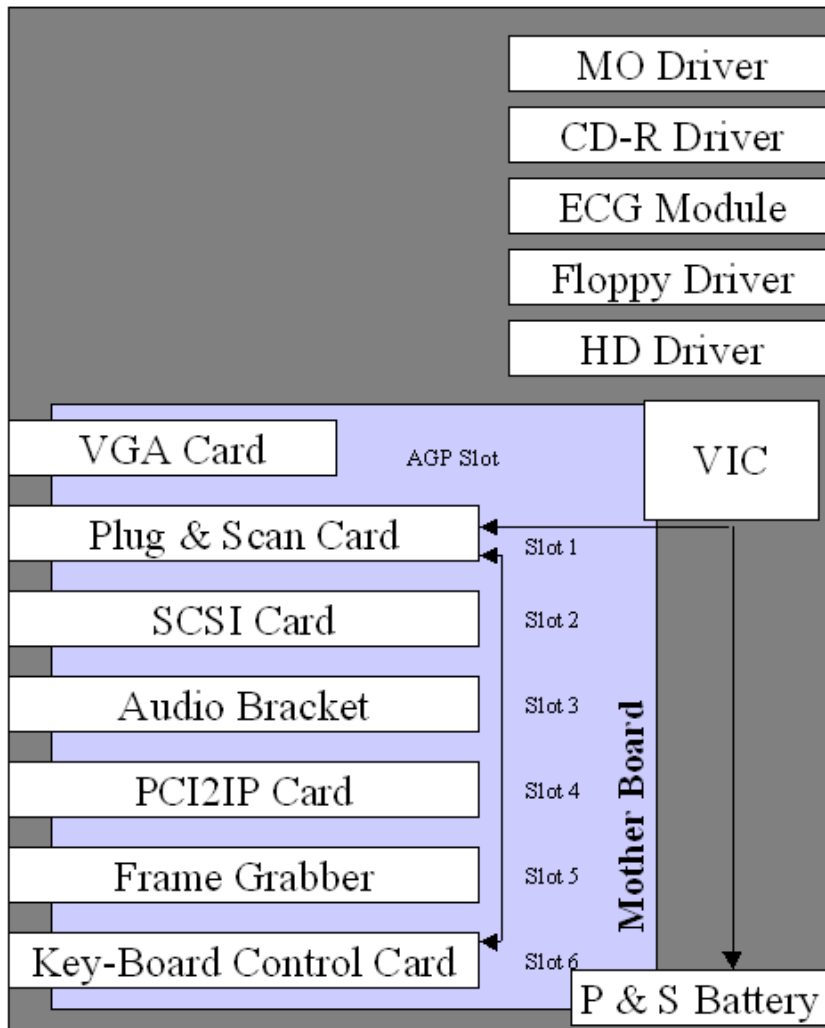

Figure 8-50 Back End Component Locations - BT02 and BT03 (RFI Configuration)

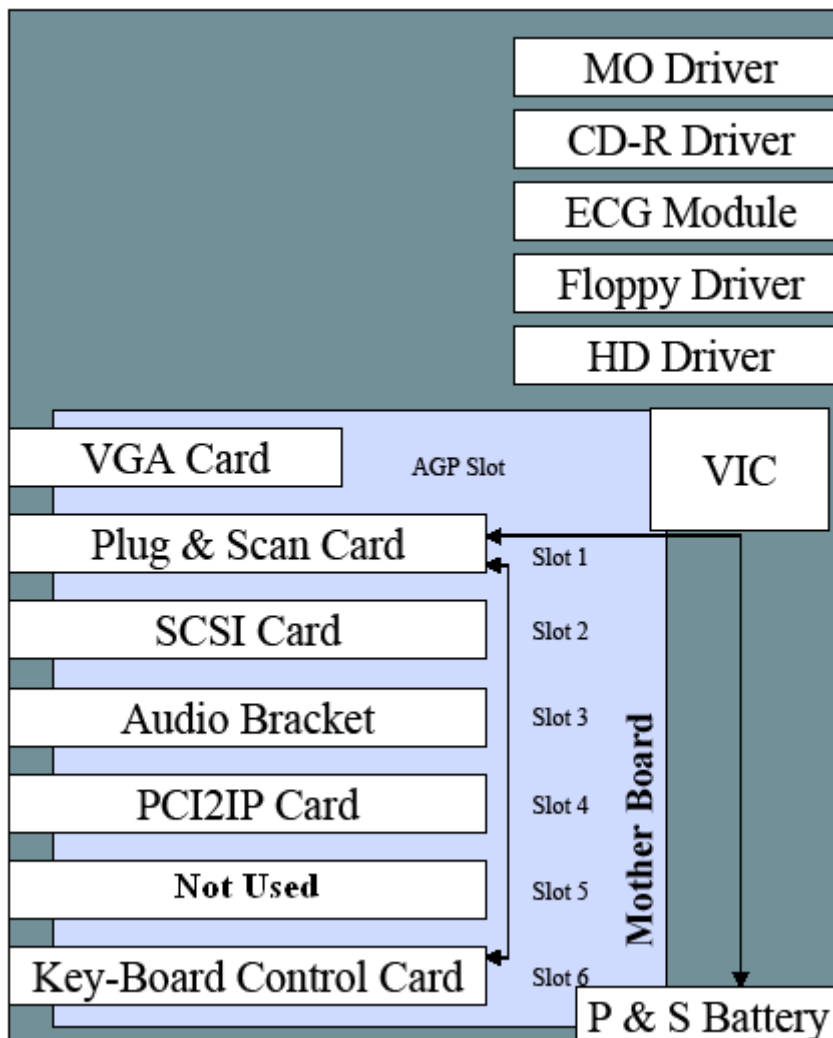

Figure 8-51 Back End Component Locations - BT02 and BT03 (RFT Configuration)

8-5-2 Back End Processor Replacement Procedure

NOTE: There are specific differences in the BEP Processor replacement procedure between replacing a **BEP1**, or **BEP 0** (Pentium III-based BEP, earlier type), or **BEP2**, with a newer type (Pentium 4-based) BEP. The variations between the types are clearly shown in the procedure steps.

8-5-2-1 Tools

Use the appropriate flat and Phillips-type screw drivers and a wire cutter, as indicated in the back end processor replacement procedure.

8-5-2-2 Preparation

- **Presets**

Note: Important: When replacing Vivid 3 BT00 BEP, Presets cannot be loaded or transferred into the new BEP. Make sure an Application specialist arrives on site to set new presets.

- **Full Incremental Backup**

Note: Important: If it is necessary to transfer archive information into the new BEP, please perform a full incremental backup of the archive onto MO or CD **before replacing BEP**.

Note: If the BEP is to be replaced, remember to perform a full incremental back-up of the Archive and User Presets - refer to the [Software Installation/Upgrade Procedure](#) on page 8 - 121.

- 1.) While the Vivid 3 system is powered ON, press Archive.
- 2.) Press **Utility** and select **Backup**.
- 3.) Start full incremental backup onto the removable media.
- 4.) When the backup procedure is completed, the yellow portion of the "pie" chart will be 0%.

8-5-2-3 Back End Processor Removal Procedure

- 1) Shut down the **Vivid™ 3** ultrasound unit, as described in [Chapter 3 - Installation](#).
- 2) Remove the Vivid™ 3 left and right side covers, as described in the [Side Covers Removal Procedure](#) on page 8 - 4.

Note: If the BEP only needs to be opened, remove only the *left* side cover.

- 3) Remove the rear cover, as described in the [Rear Cover Removal Procedure](#) on page 8 - 7.

Note: The following step is performed if removing a **BEP2** (Pentium 4-based BEP, newer type).

- 4) Remove the BEP2, as follows:
 - a.) Remove the two screws of *upper* BEP bracket, see [Figure 8-54](#) below.
 - b.) Remove the screws of the *lower* left and *right* BEP brackets ([Figure 8-54](#)).
 - c.) Disconnect all the cables from rear of the BEP, leaving the HASP key (option plug) connected.

Note: When replacing the BEP, the HASP key must be moved to the new BEP. You will need to connect the HASP key to the parallel port. Make sure you perform a full incremental back-up of the Archive and User Presets before replacing the BEP - refer to the [Software Installation/Upgrade Procedure](#) on page 8 - 121.

Note: When replacing a BEP, one must re-install software using the software provided with the system. **Do NOT use the software supplied with the BEP unless it is a version later than the software currently installed on the system.**

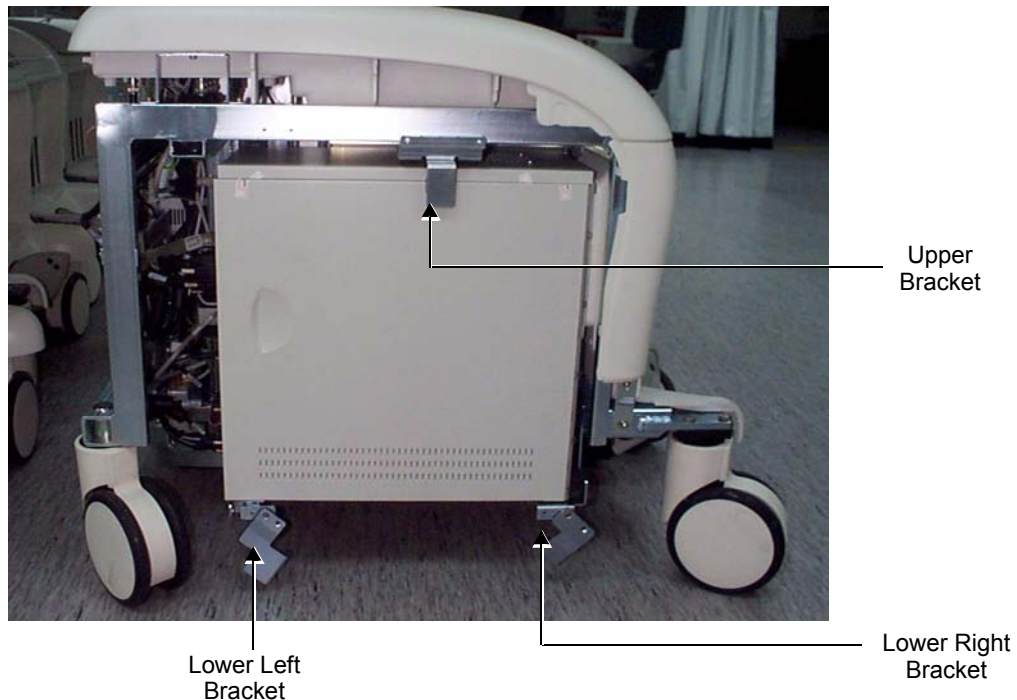

Figure 8-54 BEP - Position of Brackets on BEP2 Models

5) Place the BEP on a table and start removing the required parts (listed below), as applicable.

NOTE: *When performing these procedures, handle boards carefully and take the following precautionary measures:*



CAUTION: DO NOT TOUCH ANY BOARDS WITH INTEGRATED CIRCUITS PRIOR TO TAKING THE NECESSARY ESD PRECAUTIONS:



1. ALWAYS CONNECT YOURSELF, VIA AN ARM-WRIST STRAP, TO THE ADVISED ESD CONNECTION POINT LOCATED ON THE REAR OF THE SCANNER (TO THE RIGHT OF THE POWER CONNECTOR).

2. FOLLOW GENERAL GUIDELINES FOR HANDLING OF ELECTROSTATIC SENSITIVE EQUIPMENT.

- **For BEP2 (RFT) and (RFI) systems:**

- PC VIC Assembly - see [PC-VIC Removal Procedure](#) on page 8 - 87.

- ECG Box Assembly (Patient I/O Module) - see [BEP2 - ECG Module Removal Procedure](#) on page 8 - 85.

- Plug & Scan Battery - see [Plug & Scan Battery Removal Procedure](#) on page 8 - 70.

- PCB: Plug & Scan Card - see [Plug & Scan Board Removal Procedure](#) on page 8 - 69.

- PCB: SCSI Card - see [SCSI Board Removal Procedure](#) on page 8 - 73.

- MO Drive 5.25 - see [MO Drive Removal Procedure](#) on page 8 - 80.

- PCB: Frame Grabber (RFI systems only) - see [Frame Grabber Board Removal Procedure](#) on page 8 - 76.

- PCB: Keyboard Ctrl. Card - see [Keyboard Control Board Removal Procedure](#) on page 8 - 77.

- PCB: PC2IP Card - see [PC2IP Board Removal Procedure](#) on page 8 - 75.

8-5-2-4 Back End Processor Installation Procedure

NOTE: When performing this procedure, handle boards carefully and take the following precautionary measures:



CAUTION: DO NOT TOUCH ANY BOARDS WITH INTEGRATED CIRCUITS PRIOR TO TAKING THE NECESSARY ESD PRECAUTIONS:



1.ALWAYS CONNECT YOURSELF, VIA AN ARM-WRIST STRAP, TO THE ADVISED ESD CONNECTION POINT LOCATED ON THE REAR OF THE SCANNER (TO THE RIGHT OF THE POWER CONNECTOR).

2.FOLLOW GENERAL GUIDELINES FOR HANDLING OF ELECTROSTATIC SENSITIVE EQUIPMENT.

NOTE: Care should also be taken to install the boards in the correct slots - refer to [Figure 8-50](#) on page 8-56 and [Figure 8-51](#) on page 8-57, as applicable.

- 1) Install the MO Driver into the new BEP, as described in the [MO Drive Installation Procedure](#) on page 8 - 81, if applicable.
- 2) Remove the Octopus Card Holder as described in the [BEP2 - Octopus Card Holder Removal Procedure](#) on page 8 - 68.
- 3) Install the SCSI Board, as described in the [SCSI Board Installation Procedure](#) on page 8 - 73, if applicable.
- 4) Install the ECG Module, as described in the [BEP2 - ECG Module Installation Procedure](#) on page 8 - 86.
- 5) Install the PC VIC Assembly, as described in the [PC-VIC Installation Procedure](#) on page 8 - 89.
- 6) Install the Plug and Scan Battery (if applicable), as described in the [Plug & Scan Battery Installation Procedure](#) on page 8 - 71.
- 7) Install the Plug and Scan Board (if applicable), as described in the [Plug & Scan Board Installation Procedure](#) on page 8 - 69.
- 8) Install the PC2IP Board, as described in the [PC2IP Board Installation Procedure](#) on page 8 - 75.
- 9.) Install the Frame Grabber Board (RFI systems only), as described in the [Frame Grabber Board Installation Procedure](#) on page 8 - 76.
- 10) Install the Keyboard Control Card, as described in the [Keyboard Control Board Installation Procedure](#) on page 8 - 77.
- 11) Install the Octopus Card Holder as described in the [BEP2 - Octopus Card Holder Installation Procedure](#) on page 8 - 68.
- 12.)Carefully return the new BEP to the original position on the machine chassis.

Note: When replacing a BEP, the HASP key must be moved to the new BEP. Ensure that the HASP key is connected to the parallel port. Make sure that the nominal voltage and range is set correctly in the Technical Support Tab under System Configuration. (This must be done by an authorized GE representative). Software version 2.3 or above must be re-installed - see the [Software Installation/Upgrade Procedure](#) on page 8 - 121.

Slide the BEP slightly outwards and proceed to reconnect all the cables at the rear of the BEP as described in the following steps (refer to [Figure 8-55](#) on page 8-61). Make sure that the HASP key (option plug) is connected to the correct connector (parallel port).

NOTE: For clarification, the numbers appearing in square brackets in the following steps correspond to the numbers shown in the illustration of the new BEP Rear Panel in [Figure 8-55](#) below.

- 13.) Connect the VIC VGA OUT (Left) cable (Part No. 2252964) to the VGA OUT socket [1] on the BEP rear panel.
- 14.) Connect the VIC VGA IN (Right) cable (Part No. 2252965) to the VIC VGA IN socket [2].
- 15.) Connect the other end of this cable (Part No. 2252965) (i.e., the end labelled Back End) to the VIC VGA OUT socket [2a].
- 16.) Connect the trackball cable (Part No. 2252978) to the trackball socket [4].

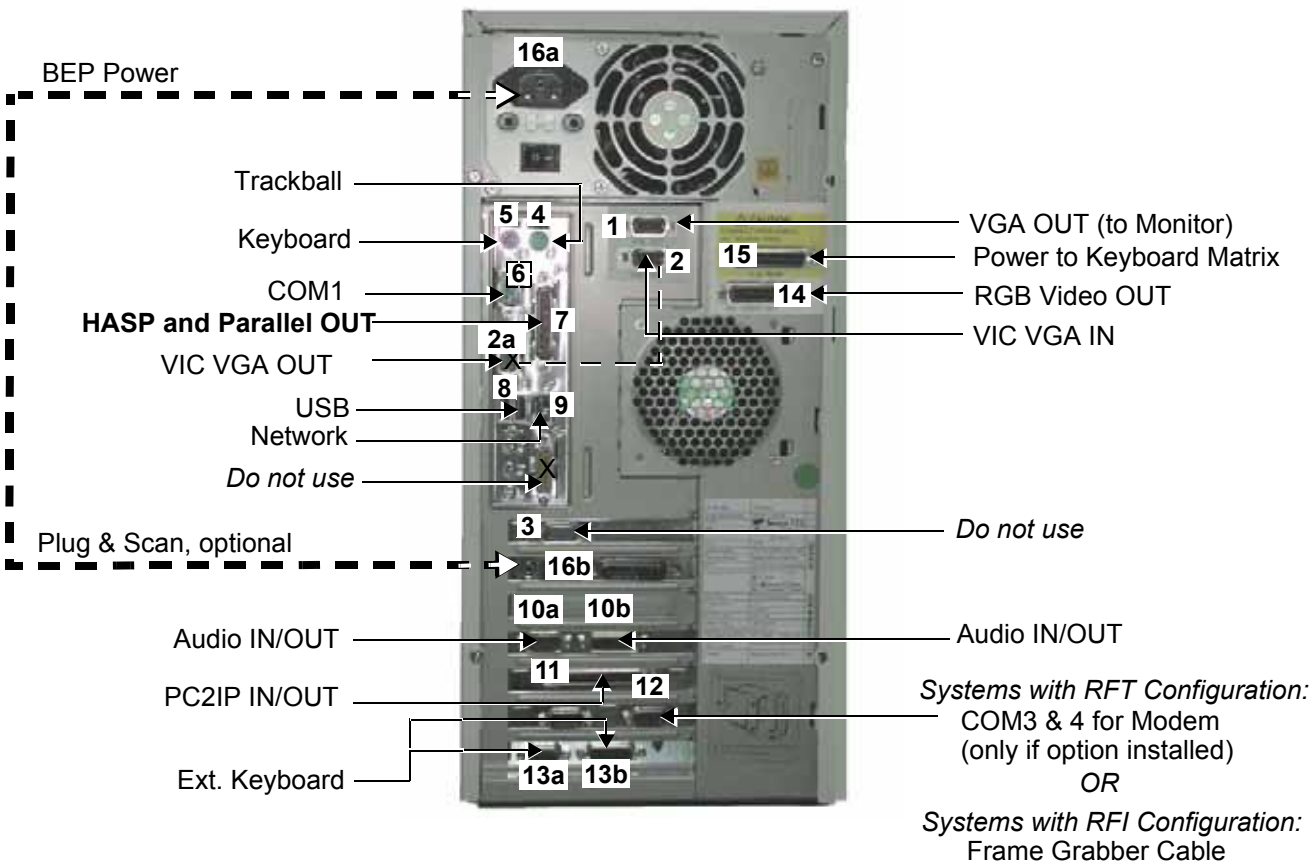

Figure 8-55 Cable Connections on new BEP Rear Panel

- 17.) Connect the keyboard cable (Part No. 2252977) to the keyboard socket [5].
- 18.) Connect the cable (Part No. 2253009) to the COM 1 socket [6].
- 19.) Connect the cable (Part No. 2253016) to the **HASP and Parallel OUT** socket [7].
- 20.) If available on the system, connect the USB cable (Part No. 2297905) to the USB socket [8].
- 21.) If available on the system, connect the Network cable (Part No. 2292972) to the Network socket [9].
- 22.) Connect the Back End Audio BKT EXT cable (Part No. 2258803) to the Audio IN/OUT socket [10b].
- 23.) Connect the Back End Audio BKT EXT cable (Part No. 2258804) to the Audio IN/OUT socket [10a].
- 24.) Connect the PC2IP cable (Part No. 2276874) to the PC2IP IN/OUT socket [11].

- 25.) If available on the system, connect the modem communication cable (Part No. 2320338) to the COM 3 and 4 socket [12], OR connect the frame grabber cable (Part No. 2371429) to the socket [12].
- 26.) Connect the Back End KB Cont P1 cable (Part No. 2252975) to the Ext Keyboard socket [13b].
- 27.) Connect the Back End KB Cont P2 cable (Part No. 2252976) to the Ext Keyboard socket [13a].
- 28.) Connect the VIC/ Rear Panel left connector cable (Part No. 2253011) to the RGB Video OUT socket [14].
- 29.) Connect the Keyboard/VIC External power cable (Part No. 2252976) to the power to Keyboard Matrix socket [15].

Note: **IMPORTANT - Do NOT connect the HASP key to this socket!** - refer to [step 19](#) above [connection to socket 7].

- 30.) **For systems without a UPS:**
Connect the BEP power cable (Part No. 2276876) to the power input socket [16a]

For systems using a UPS:

Connect the UPS power cable (Part No.2307289) to the Plug and Scan socket [16b] and then connect the BEP/Modem power cable (Part No. 2300847) to the power input socket [16a].

- 31) Facing the side cover, push the BEP as far to the right as possible, and tighten first the left lower bracket, then the right lower bracket and finally the bracket on its upper left side. Use two screws to fasten each bracket.
- 32) Turn ON the system and boot-up in *Technical Support* mode - make sure the T-plug (dongle) is inserted into the parallel or USB port on the Vivid™ 3 rear connectors panel.
- 33.) Re-install the Software - see the [Software Installation/Upgrade Procedure](#) on page 8 - 121.

The system will perform four reboots before completing the software installation, after which the probe select screen will be displayed.

Note: When replacing a BEP, one must re-install software using the software provided with the system. **Do NOT use the software supplied with the BEP unless it is a version later than the software currently installed on the system.**

Note: IMPORTANT: During the software installation, the system will display a few messages; reply to all by selecting **OK**, or **Cancel** (all can be ignored).

- 34.) After a complete installation of the software and patches if applicable (in accordance with [Table 8-4](#)), boot-up the system.

Table 8-4 Software Installation Compatibility

Vivid 3 BT00 H/Ware	Vivid 3 RFT	Vivid 3 RFI
1. SW Version 2.3.11	SW Version 3.3	SW Version 3.6
2. VGA Upgrade Patch		
3. Patch 2.3.12		
4. CDRW Patch		
5. CD Probe Overheating Protection Patch		

- 35.) Press the **Config** button on the control console; the System Configuration dialog box is displayed.
- 36.) Trackball to the *Technical Support* tab and press **Select**.

The dialog box displays the Technical Support Tab as shown in [Figure 8-56](#).

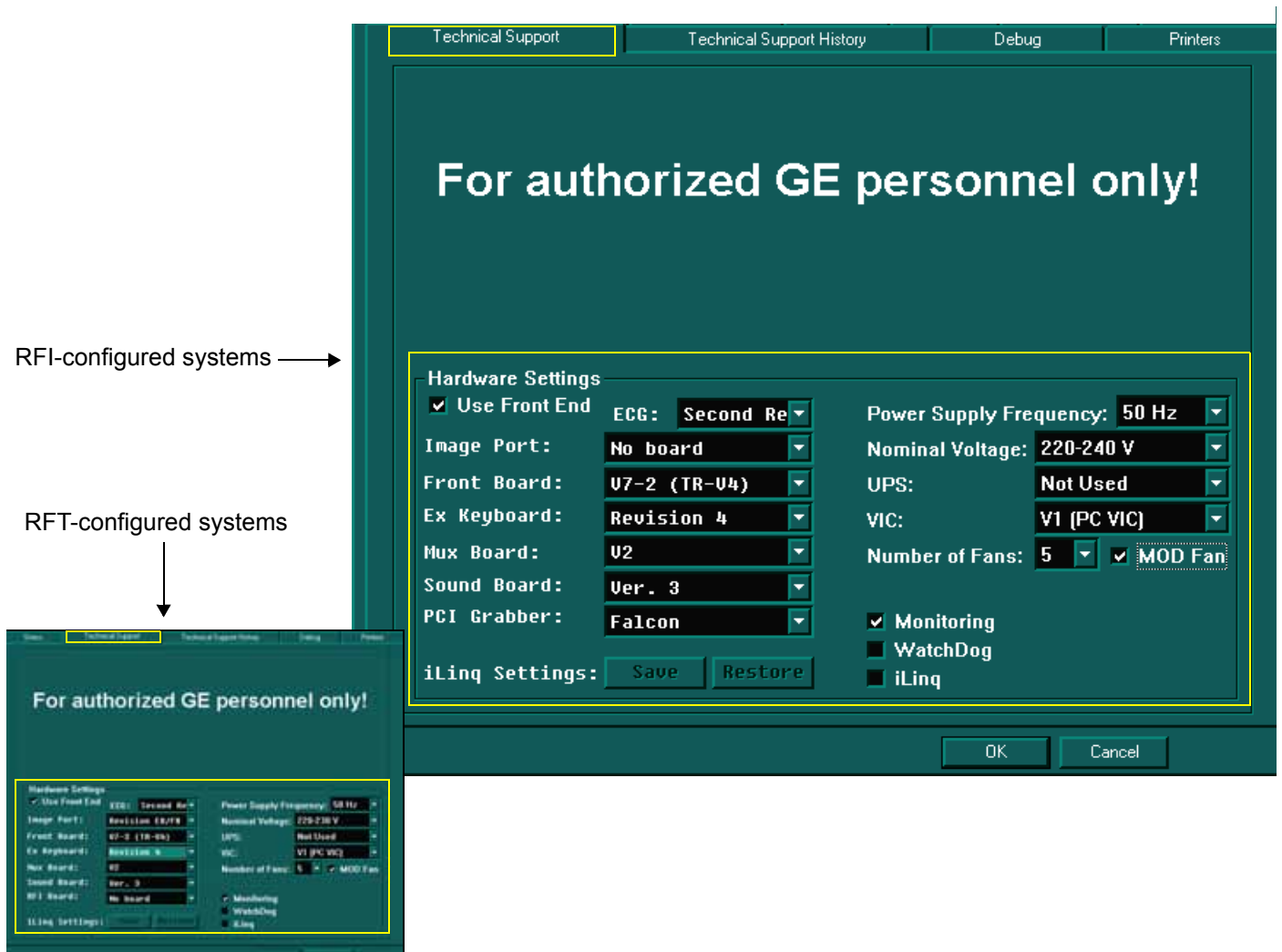

Figure 8-56 System Configuration - Technical Support Tab

37.) Select the appropriate settings, as follows:

- * Ex Keyboard - **Revision 4**
- * Sound Board - **Ver. 3**
- * Number of Fans - Set to **7** for BT00 systems; set to **5** for other systems
- * MOD Fan - Set to ON (checkbox activated)
- * UPS - Change the UPS setting to **Used** or **Not Used**, as appropriate. If the *Plug & Scan* option was purchased, the UPS setting can be selected as **Used**. If this option not purchased, select **Not Used**.
- * VIC - Set to **PC VIC**
- * Nominal Voltage - Set to the appropriate local voltage setting.

38) Perform a complete functional check of the system, as described in [Chapter 4 - Functional Checks](#).

39) Install the Vivid™ 3 rear, left and right covers - refer to the [Side Covers Installation Procedure](#) on page 8 - 4 and [Rear Cover Installation Procedure](#) on page 8 - 7.

8-5-3 BEP1 Cover Replacement Procedure

NOTE: BEP1 refers to a Pentium III-based BEP (earlier type).

8-5-3-1 Tools

Use the appropriate flat and Phillips-type screw drivers, as indicated in the Cover & Octopus Card Holder replacement procedure.

8-5-3-2 Preparation

Shut down the Vivid™ 3 ultrasound unit, as described in [Chapter 3 - Installation](#).

8-5-3-3 BEP1 - Left and Right Side Cover Removal Procedure

Note: The procedure is the same for *Left* and *Right* side covers.

- 1) Remove the two screws that hold the cover in position (refer to [Figure 8-57](#) below).
- 2) Slide the side of the BEP1 *backwards* and *outwards* away from the BEP.

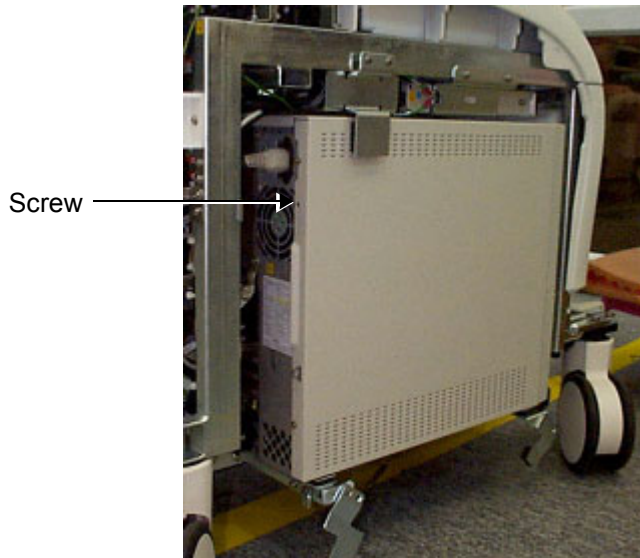

Figure 8-57 BEP1 - Side Cover Screws

8-5-3-4 BEP1 - Left and Right Side Cover Installation Procedure

Note: The procedure is the same for *Left* and *Right* side covers.

- 1) Return the cover and slide it into position on the side of the BE1P.
- 2.) Replace and tighten the two screws to hold the cover firmly in position (refer to [Figure 8-57](#), above).

8-5-3-5 BEP1 - Front Cover Removal Procedure

- 1) Remove the screw that secures the front cover in position - see [Figure 8-58](#) on page 8-65.
- 2) Press the two plastic latches, while pushing the front cover until it released.

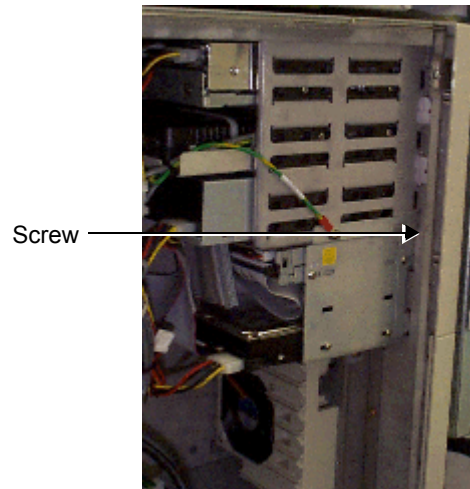

Figure 8-58 BEP1 - Front Cover Screw

8-5-3-6 BEP1 - Front Cover Installation Procedure

- 1) Return the front cover, pushing it into position on the front of the BEP1.
- 2) Replace and tighten the screw that secures the front cover in position - see [Figure 8-58](#), above.

8-5-4 BEP2 Cover and Octopus Card Holder Replacement Procedure

NOTE: BEP2 refers to a Pentium 4-based BEP (newer type).

8-5-4-1 Tools

Use the appropriate flat and Phillips-type screw drivers, as indicated in the BEP cover replacement procedure.

8-5-4-2 Preparation

Shut down the Vivid™ 3 ultrasound unit, as described in [Chapter 3 - Installation](#).

8-5-4-3 BEP2 - Side Cover Removal Procedure

- 1) Remove the two screws (that secure the side cover in position) from the rear of the BEP (see [Figure 8-59](#) below).
- 2) Slide the cover backwards and remove it.

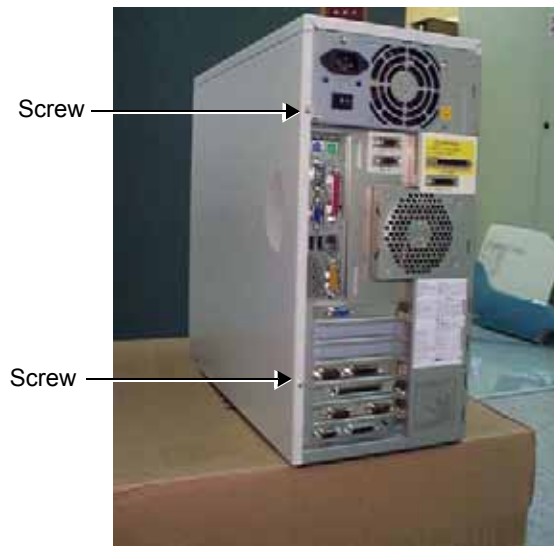

Figure 8-59 Side Cover - BEP2

8-5-4-4 BEP2 - Side Cover Installation Procedure

- 1) Return the cover to the side of the BEP and slide it forwards into position.
- 2) Replace and tighten the two screws to hold the cover firmly in position ([Figure 8-59](#) on page 8-66).

8-5-4-5 BEP2 - Front Cover Removal Procedure

- 1) Remove the two screws that secure the BEP front cover in position - see [Figure 8-60](#) on page 8-67.
- 2) Press on the two latches on the side to release the cover.
- 3.) Pull the cover forward (see [Figure 8-61](#) on page 8-67) and remove it.



Figure 8-60 Front Cover - BEP2



Figure 8-61 Front Cover Removal - BEP2

8-5-4-6 BEP2 - Front Cover Installation Procedure

- 1) Return the front cover to the front of the BEP and press the two latches on the side, in order to push the cover back into position.
- 2) Replace and tighten the two screws to secure the BEP front cover in position - see [Figure 8-60](#) on page 8-67.

8-5-4-7 BEP2 - Octopus Card Holder Removal Procedure

- 1) Remove the three screws that secure the Octopus Card Holder in position as shown in [Figure 8-62](#) below.

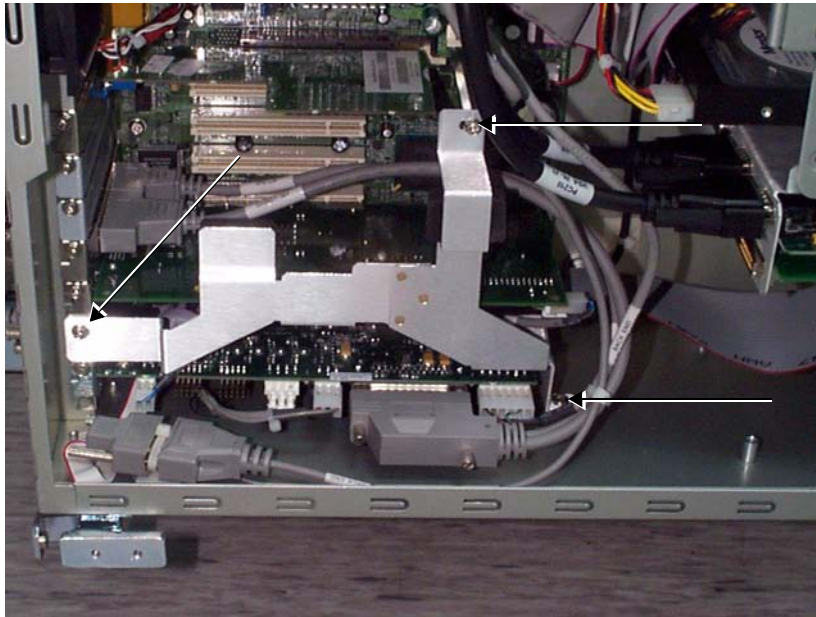

Figure 8-62 Octopus Card Holder - BEP1

- 2.) Remove the Octopus Card Holder.

8-5-4-8 BEP2 - Octopus Card Holder Installation Procedure

- 1) Place the Octopus Card Holder in position on the BEP part, holding it firmly in place.
- 2) Return the three screws and tighten them to hold the Octopus Card Holder securely in position, as shown in [Figure 8-62](#), above.

8-5-5 Plug & Scan Board Replacement Procedure

8-5-5-1 Tools

Use the appropriate flat and Phillips-type screw drivers and a wire cutter, as indicated in the Plug & Scan board replacement procedure.

8-5-5-2 Preparation

Shut down the Vivid™ 3 ultrasound unit, as described in [Chapter 3 - Installation](#). Voltage may exist in the system when a Plug & Scan is present. Ensure that a full shutdown of the system is performed, otherwise voltage might be present that can cause injury and/or damage.

8-5-5-3 Plug & Scan Board Removal Procedure

- 1) Remove the machine's rear and left and right side covers, as described in [Side Covers Removal Procedure](#) on page 8 - 4 and [Rear Cover Removal Procedure](#) on page 8 - 7.
- 2) Disconnect the power cable from the rear of the BEP.
- 3) Remove the BEP side cover, as described in the appropriate procedure: [BEP1 - Left and Right Side Cover Removal Procedure](#) on page 8 - 64, or [BEP2 - Side Cover Removal Procedure](#) on page 8 - 66.
- 4) If applicable, remove the octopus card holder as described in the [BEP2 - Octopus Card Holder Removal Procedure](#) on page 8 - 68.
- 5) Disconnect all cables connected to the Plug & Scan board from the keyboard control card, the battery and the power supply.

Note: Counting from the top, the board is positioned in the first PCI slot.

- 6) Release the securing screw located on the left of the board bracket.
- 7) Gently remove the Plug & Scan board from the BEP.

8-5-5-4 Plug & Scan Board Installation Procedure

- 1) Gently insert the Plug & Scan board into its slot.

Note: Counting from the top, the board is positioned in the first PCI slot.

- 2) Fasten the board with the screw on the left of the bracket.
- 3) Reconnect the cables to the Plug & Scan board from the keyboard control card, the battery and the power supply.
- 4.) If applicable, mount the octopus card holder as described in the [BEP2 - Octopus Card Holder Installation Procedure](#) on page 8 - 68
- 5) Mount the BEP side cover as described in the appropriate procedure: [BEP1 - Left and Right Side Cover Installation Procedure](#) on page 8 - 64, or [BEP2 - Side Cover Installation Procedure](#) on page 8 - 66.
- 6) Reconnect the power cable to the rear of the BEP.
- 7) Install the Vivid™ 3 rear, and left and right side covers, as described in the [Side Covers Installation Procedure](#) on page 8 - 4, and the [Rear Cover Installation Procedure](#) on page 8 - 7.

Note: Perform a complete functional check of the Plug & Scan, as described in [Chapter 4 - Functional Checks](#).

8-5-6 Plug & Scan Battery Replacement Procedure

NOTE: **IMPORTANT** - If the Plug & Scan battery is replaced, ensure that you properly transport and dispose of the old battery according to the procedures established by your facility, company, or regional regulatory agency.

8-5-6-1 Tools

Use the appropriate flat and Phillips-type screw drivers, a wire cutter and the appropriate Hex wrenches, as indicated in the Plug & Scan battery replacement procedure.

8-5-6-2 Preparation

Shut down the Vivid™ 3 ultrasound unit, as described in [Chapter 3 - Installation](#). Voltage may exist in the system when a Plug & Scan is present. Ensure that a full shutdown of the system is performed, otherwise voltage might be present that can cause injury and/or damage.

8-5-6-3 Plug & Scan Battery Removal Procedure

- 1) Remove the left cover, as described in the [Side Covers Removal Procedure](#) on page 8 - 4.
- 2) Disconnect the power cable from the rear of the BEP.
- 3) Remove the BEP cover as described [Back End Processor Replacement Procedure](#) on page 8 - 58. The Plug & Scan battery and its cover are located to the right of the BEP.
- 4) Remove the screws that secure the battery bracket in position (see [Figure 8-63](#) below - BEP1 has *three* screws; BEP2 has *two*); remove the bracket.

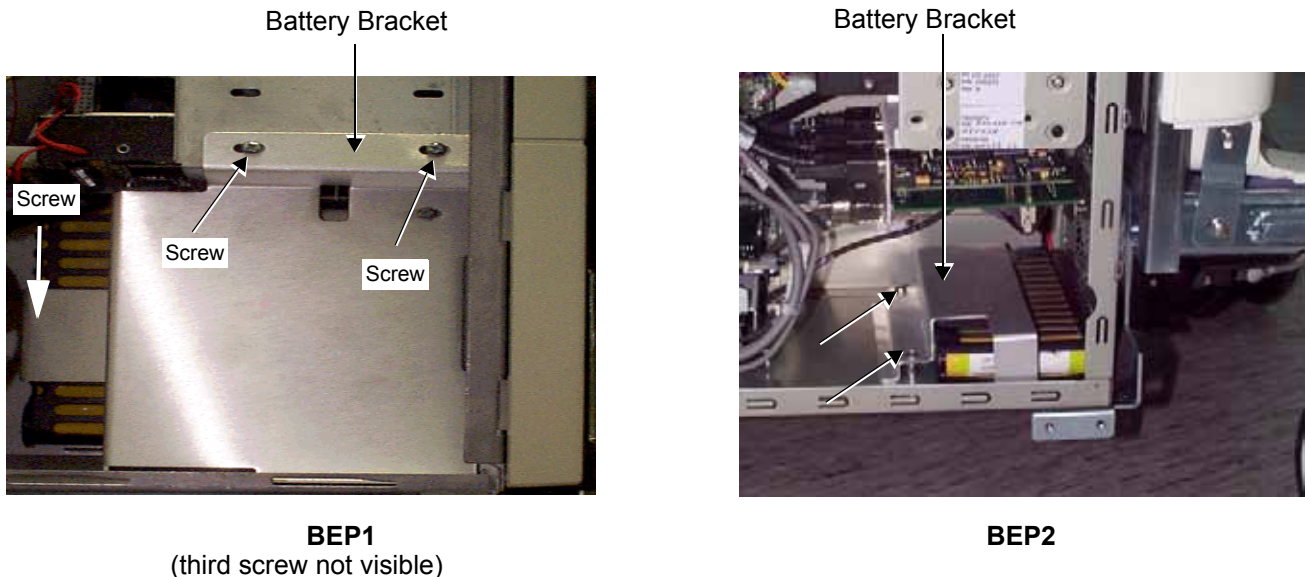

Figure 8-63 Plug & Scan Battery Bracket and Screws

- 5) Disconnect the battery cable from the Plug & Scan board.

- 6) The battery is fastened with velcro strips to the inner wall of the BEP. Remove the battery by pulling it away from the velcro.



Figure 8-64 Plug & Scan Battery Removed

8-5-6-4 Plug & Scan Battery Installation Procedure

Note: When replacing the battery, first pull off and remove the top layer from the two velcro fastening strips on the rear of the battery, as shown below. These strips are not required because two similar strips from the old battery are already found on the inner wall of the BEP.

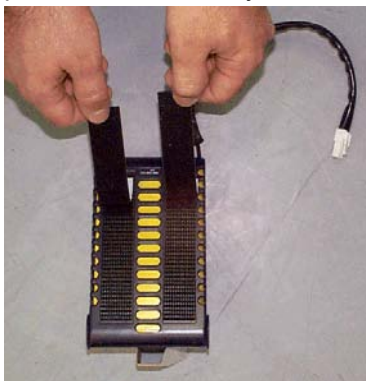

Figure 8-65 Removing Plug & Scan Velcro Strips

- 1) Place the battery inside the battery bracket. Ensure that the cable is positioned at the lower end and that the rear of the battery (with the two velcro strips) faces the inner wall of the BEP.
- 2) Mount the battery and bracket in its original location in the BEP, tightening the screws (two or three as shown in [Figure 8-63](#) on page 8-70) to secure it firmly in position.
- 3) Reconnect the battery cable to the Plug & Scan board.
- 4) Mount the BEP side cover as described in the appropriate procedure: [BEP1 - Left and Right Side Cover Installation Procedure](#) on page 8 - 64, or [BEP2 - Side Cover Installation Procedure](#) on page 8 - 66.
- 5) Reconnect the power cable to the rear of the BEP.
- 6) Return the left cover, as described in the [Side Covers Installation Procedure](#) on page 8 - 4.

Note: Perform a complete functional check of the Plug & Scan (see [Chapter 4 - Functional Checks](#)).

8-5-7 VGA AGP Board Replacement Procedure



CAUTION: DO NOT TOUCH ANY BOARDS WITH INTEGRATED CIRCUITS PRIOR TO TAKING THE NECESSARY ESD PRECAUTIONS:



1. ALWAYS CONNECT YOURSELF, VIA AN ARM-WRIST STRAP, TO THE ADVISED ESD CONNECTION POINT LOCATED ON THE REAR OF THE SCANNER (TO THE RIGHT OF THE POWER CONNECTOR).

2. FOLLOW GENERAL GUIDELINES FOR HANDLING OF ELECTROSTATIC SENSITIVE EQUIPMENT.

8-5-7-1 Tools

Use the appropriate flat and Phillips-type screw drivers and a wire cutter as indicated in the SCSI board replacement procedure.

8-5-7-2 Preparation

Shut down the Vivid™ 3 ultrasound unit, as described in [Chapter 3 - Installation](#).

8-5-7-3 VGA AGP Board Removal Procedure

- 1) Remove the Vivid™ 3 rear and left and right side covers - see the [Rear Cover Removal Procedure](#) on page 8 - 7 and the [Side Covers Installation Procedure](#) on page 8 - 4.
- 2) Disconnect the power cable from the rear of the BEP.
- 3) Remove the BEP side cover, as described in the [BEP2 - Side Cover Removal Procedure](#) on page 8 - 66.
- 4) Remove the octopus card holder as described in the [BEP2 - Octopus Card Holder Removal Procedure](#) on page 8 - 68.
- 5) Disconnect the cable (Part No. 2252965) connected to the AGP board.

Note: Counting from the top, the AGP board is positioned in the first slot (AGP).

- 6) Release the securing screw located on the left of the board bracket.
- 7) Gently remove the AGP board from the BEP.

8-5-7-4 VGA AGP Board Installation Procedure

- 1) Gently insert the AGP board into its slot.

Note: Counting from the top, the AGP board is positioned in the first slot.

- 2) Fasten the board with the screw on the left of the bracket.
- 3) Reconnect the cable (disconnected in [step 5](#) above) to the AGP board.
- 4.) Install the octopus card holder as described in the [BEP2 - Octopus Card Holder Installation Procedure](#) on page 8 - 68.
- 5) Install the BEP side covers, as described in the [BEP2 - Side Cover Installation Procedure](#) on page 8 - 66.
- 6) Reconnect the power cable to the rear of the BEP.
- 7) Return the Vivid™ 3 rear and left and right side covers - see the [Rear Cover Installation Procedure](#) on page 8 - 7 and the [Side Covers Installation Procedure](#) on page 8 - 4.

8-5-8 SCSI Board Replacement Procedure



CAUTION: DO NOT TOUCH ANY BOARDS WITH INTEGRATED CIRCUITS PRIOR TO TAKING THE NECESSARY ESD PRECAUTIONS:



1. ALWAYS CONNECT YOURSELF, VIA AN ARM-WRIST STRAP, TO THE ADVISED ESD CONNECTION POINT LOCATED ON THE REAR OF THE SCANNER (TO THE RIGHT OF THE POWER CONNECTOR).

2. FOLLOW GENERAL GUIDELINES FOR HANDLING OF ELECTROSTATIC SENSITIVE EQUIPMENT.

8-5-8-1 Tools

Use the appropriate flat and Phillips-type screw drivers and a wire cutter as indicated in the SCSI board replacement procedure.

8-5-8-2 Preparation

Shut down the Vivid™ 3 ultrasound unit, as described in [Chapter 3 - Installation](#).

8-5-8-3 SCSI Board Removal Procedure

- 1) Remove the Vivid™ 3 rear and left and right side covers - see the [Rear Cover Removal Procedure](#) on page 8 - 7 and the [Side Covers Installation Procedure](#) on page 8 - 4.
- 2) Disconnect the power cable from the rear of the BEP.
- 3) Remove the BEP side covers, as described in the appropriate procedure: [BEP1 - Left and Right Side Cover Removal Procedure](#) on page 8 - 64, or [BEP2 - Side Cover Removal Procedure](#) on page 8 - 66.
- 4) If applicable, remove the octopus card holder as described in the [BEP2 - Octopus Card Holder Removal Procedure](#) on page 8 - 68.
- 5) Disconnect the cable connecting the SCSI board to the MO.

Note: Counting from the top, the SCSI board is positioned in the second PCI slot.

- 6) Release the securing screw located on the left of the board bracket.
- 7) Gently remove the SCSI board from the BEP.

8-5-8-4 SCSI Board Installation Procedure

- 1) Gently insert the SCSI board into its slot.

Note: Counting from the top, the SCSI board is positioned in the second PCI slot.

- 2) Fasten the board with the screw on the left of the bracket.
- 3) Reconnect the cable from SCSI board to the MO.
- 4.) If applicable, install the octopus card holder as described in the [BEP2 - Octopus Card Holder Installation Procedure](#) on page 8 - 68.
- 5) Install the BEP side covers, as described in the appropriate procedure: [BEP1 - Left and Right Side Cover Removal Procedure](#) on page 8 - 64, or [BEP2 - Side Cover Installation Procedure](#) on page 8 - 66.
- 6) Reconnect the power cable to the rear of the BEP.

- 7) Return the Vivid™ 3 rear and left and right side covers - see the [Rear Cover Installation Procedure](#) on page 8 - 7 and the [Side Covers Installation Procedure](#) on page 8 - 4.

Note: Perform a complete functional check of the MO, as described in [Chapter 4 - Functional Checks](#).

8-5-9 PC2IP Board Replacement Procedure

8-5-9-1 Tools

Use the appropriate flat and Phillips-type screw drivers and a wire cutter as indicated in the PC2IP board replacement procedure.

8-5-9-2 Preparation

Shut down the Vivid™ 3 ultrasound unit, as described in [Chapter 3 - Installation](#).

8-5-9-3 PC2IP Board Removal Procedure

- 1) Remove the Vivid™ 3 left and right side covers, and rear cover - see the [Rear Cover Removal Procedure](#) on page 8 - 7 and the [Side Covers Installation Procedure](#) on page 8 - 4.
- 2) Disconnect the power cable from the rear of the BEP.
- 3) Remove the BEP side covers, as described in the appropriate procedure: [BEP1 - Left and Right Side Cover Removal Procedure](#) on page 8 - 64, or [BEP2 - Side Cover Removal Procedure](#) on page 8 - 66.
- 4) If applicable, remove the octopus card holder as described in the [BEP2 - Octopus Card Holder Removal Procedure](#) on page 8 - 68.
- 5) Disconnect the PCI cable that is connected to the BEP.

Note: Counting from the top, the PC2IP board is positioned in the fourth slot.

- 6) Release the securing screw located on the left of the board bracket.
- 7) Gently remove the PC2IP board from the BEP.

8-5-9-4 PC2IP Board Installation Procedure

- 1) Gently insert the PC2IP board into its slot.

Note: Counting from the top, the PC2IP board is positioned in the fourth slot.

- 2) Fasten the board with the screw on the left of the bracket.
- 3) Reconnect the PCI cable that is connected to the BEP.
- 4.) If applicable, install the octopus card holder as described in the [BEP2 - Octopus Card Holder Installation Procedure](#) on page 8 - 68.
- 5) Reconnect the power cable to the rear of the BEP.
- 6.) Install the BEP side covers, as described in the appropriate procedure: [BEP1 - Left and Right Side Cover Removal Procedure](#) on page 8 - 64, or [BEP2 - Side Cover Installation Procedure](#) on page 8 - 66.
- 7) Return the Vivid™ 3 rear, left and right covers - see the [Side Covers Installation Procedure](#) on page 8 - 4 and [Rear Cover Replacement Procedures](#) on page 8 - 7.

Note: Perform a complete diagnostic check of the system, as described in [Chapter 7 - Diagnostics/Troubleshooting](#).

8-5-10 Frame Grabber Board Replacement Procedure

NOTE: The procedures described in this section are only applicable to Vivid™ 3 systems with the RFI configuration.

8-5-10-1 Tools

Use the appropriate flat and Phillips-type screw drivers and a wire cutter as indicated in the frame grabber board replacement procedure.

8-5-10-2 Preparation

Shut down the Vivid™ 3 ultrasound unit, as described in [Chapter 3 - Installation](#).

8-5-10-3 Frame Grabber Board Removal Procedure

- 1) Remove the Vivid™ 3 left and right side covers, and rear cover - see the [Rear Cover Removal Procedure](#) on page 8 - 7 and the [Side Covers Installation Procedure](#) on page 8 - 4.
- 2) Disconnect the power cable from the rear of the BEP.
- 3) Remove the BEP side covers, as described in the [BEP2 - Side Cover Removal Procedure](#) on page 8 - 66.
- 4) If applicable, remove the octopus card holder as described in the [BEP2 - Octopus Card Holder Removal Procedure](#) on page 8 - 68.
- 5) Disconnect the frame grabber cable from the rear of the frame grabber board.

Note: Counting from the top, the frame grabber board is positioned in the fifth PCI slot.

- 6) Release the securing screw located on the left of the board bracket.
- 7) Gently remove the frame grabber board from the BEP.

8-5-10-4 Frame Grabber Board Installation Procedure

- 1) Gently insert the frame grabber board into its slot.

Note: Counting from the top, the frame grabber board is positioned in the fifth PCI slot.

- 2) Fasten the board with the screw on the left of the bracket.
- 3) Reconnect the frame grabber cable to the rear of the frame grabber board.
- 4.) If applicable, install the octopus card holder as described in the [BEP2 - Octopus Card Holder Installation Procedure](#) on page 8 - 68.
- 5) Reconnect the power cable to the rear of the BEP.
- 6) Install the BEP side covers, as described in the [BEP2 - Side Cover Installation Procedure](#) on page 8 - 66.
- 7) Return the Vivid™ 3 rear, left and right covers - see the [Side Covers Installation Procedure](#) on page 8 - 4 and [Rear Cover Replacement Procedures](#) on page 8 - 7.

Note: Perform a complete diagnostic check of the system, as described in [Chapter 7 - Diagnostics/Troubleshooting](#).

8-5-11 Keyboard Control Board Replacement Procedure

8-5-11-1 Tools

Use the appropriate flat and Phillips-type screw drivers and a wire cutter as indicated in the keyboard control board replacement procedure.

8-5-11-2 Preparation

Shut down the Vivid™ 3 ultrasound unit, as described in [Chapter 3 - Installation](#).

8-5-11-3 Keyboard Control Board Removal Procedure

- 1) Remove the Vivid™ 3 left and right side covers, and rear cover - see the [Rear Cover Removal Procedure](#) on page 8 - 7 and the [Side Covers Installation Procedure](#) on page 8 - 4.
- 2) Disconnect the power cable from the rear of the BEP.
- 3) Remove the BEP side covers, as described in the appropriate procedure: [BEP1 - Left and Right Side Cover Removal Procedure](#) on page 8 - 64, or [BEP2 - Side Cover Removal Procedure](#) on page 8 - 66.
- 4) If applicable, remove the octopus card holder as described in the [BEP2 - Octopus Card Holder Removal Procedure](#) on page 8 - 68.
- 5) Disconnect the two keyboard control cables that are connected at the rear of the BEP, and all the internal cables connected to the keyboard control board.

Note: Counting from the top, the keyboard control board is positioned in the sixth PCI slot.

- 6) Release the securing screw located on the left of the board bracket.
- 7) Gently remove the keyboard control board from the BEP.

8-5-11-4 Keyboard Control Board Installation Procedure

- 1) Gently insert the keyboard control board into its slot.

Note: Counting from the top, the keyboard control board is positioned in the sixth PCI slot.

- 2) Fasten the board with the screw on the left of the bracket.
- 3) Reconnect the two keyboard control cables that are connected at the rear of the BEP, and connect the other internal cables to the keyboard control board.
- 4.) If applicable, install the octopus card holder as described in the [BEP2 - Octopus Card Holder Installation Procedure](#) on page 8 - 68.
- 5) Install the BEP side covers, as described in the appropriate procedure: [BEP1 - Left and Right Side Cover Removal Procedure](#) on page 8 - 64, or [BEP2 - Side Cover Installation Procedure](#) on page 8 - 66.
- 6) Reconnect the power cable to the rear of the BEP.
- 7) Return the Vivid™ 3 rear, left and right covers - see the [Side Covers Installation Procedure](#) on page 8 - 4 and [Rear Cover Replacement Procedures](#) on page 8 - 7.

Note: Perform a complete diagnostic of the system, as described in [Chapter 7 - Diagnostics/Troubleshooting](#).

8-5-12 CDRW Drive Replacement Procedure

8-5-12-1 Tools

Use the appropriate flat and Phillips-type screw drivers and a wire cutter.

When installing a new CDRW Drive on systems that have software versions earlier than 3.1, it is necessary to install the CD-RW patch (P/N 2413448) that is supplied as part of the CD-RW Kit, as shown below.

CD-RW Kit part number 2413449 consists of the following items:

ITEM PART NO.	DESCRIPTION
2346017	CD-RW Drive
2413448	CD-RW Patch
2413450-100	CD Patch CD-RW Installation Instructions

8-5-12-2 Preparation

Shut down the Vivid™ 3 ultrasound unit, as described in [Chapter 3 - Installation](#).

8-5-12-3 CDRW Drive Removal Procedure

- 1) Remove the Vivid™ 3 left and right side covers, and rear cover - see the [Rear Cover Removal Procedure](#) on page 8 - 7 and the [Side Covers Installation Procedure](#) on page 8 - 4.
- 2) Disconnect the power cable from the rear of the BEP.
- 3) Remove the BEP left and right side covers, as described in the appropriate procedure: [BEP1 - Left and Right Side Cover Removal Procedure](#) on page 8 - 64, or [BEP2 - Side Cover Removal Procedure](#) on page 8 - 66.
- 4) Remove the BEP front cover as described in the appropriate procedure: [BEP1 - Front Cover Removal Procedure](#) on page 8 - 64, or [BEP2 - Front Cover Removal Procedure](#) on page 8 - 66.
- 5) Remove the cables (data and power) that connect to the rear of the CDRW Drive.
- 6.) Carefully slide the CDRW Drive out from the front of the BEP as shown in [Figure 8-66](#) below.



Figure 8-66 CDRW Drive Removal

8-5-12-4 CDRW Drive Installation Procedure

Note: Before installing the new CDRW Drive, make sure the jumper settings closest to the data cable are shorted as follows:

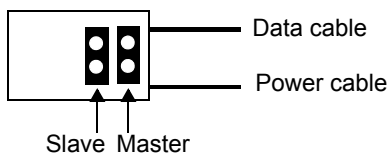

- 1.) *For BEP1:*
Assemble the black *plastic* slides provided with the CDRW drive, or use those from the drive previously removed.
For BEP2:
Use the *metal* slides provided with the CDRW drive, or use those from the drive previously removed.
- 2) Carefully slide the CDRW Drive into the front of the BEP (refer to [Figure 8-66](#) on page 8-78).
- 3) Reconnect the cables (data and power) to the rear of the CDRW Drive.
- 4) Install the BEP left and right side covers, as described in the appropriate procedure: [BEP1 - Left and Right Side Cover Installation Procedure](#) on page 8 - 64, or [BEP2 - Side Cover Installation Procedure](#) on page 8 - 66.
- 5.) Reconnect the power cable to the rear of the BEP.
- 6) Return the Vivid™ 3 rear, left and right covers - see the [Side Covers Installation Procedure](#) on page 8 - 4 and [Rear Cover Replacement Procedures](#) on page 8 - 7.

8-5-13 MO Drive Replacement Procedure

8-5-13-1 Tools

Use the appropriate flat and Phillips-type screw drivers and a wire cutter.

8-5-13-2 Preparation

Shut down the Vivid™ 3 ultrasound unit, as described in [Chapter 3 - Installation](#).

8-5-13-3 MO Drive Removal Procedure

- 1) Disconnect the mains AC power cable for the mains power wall outlet.
- 2) Remove the Vivid™ 3 left and right side covers - refer to the [Side Covers Removal Procedure](#) on page 8 - 4.
- 3.) Remove the Vivid™ 3 rear cover - refer to the [Rear Cover Removal Procedure](#) on page 8 - 7.
- 4) Remove the BEP left and right side covers, as described in the appropriate procedure: [BEP1 - Left and Right Side Cover Removal Procedure](#) on page 8 - 64, or [BEP2 - Side Cover Removal Procedure](#) on page 8 - 66.
- 5) Remove the BEP front cover as described in the appropriate procedure: [BEP1 - Front Cover Removal Procedure](#) on page 8 - 64, or [BEP2 - Front Cover Removal Procedure](#) on page 8 - 66.
- 6) Remove the cables (data and power) that connect to the rear of the MO Drive.
- 7.) For BEP2, remove the two screws from each side of the MO that hold the MO Drive inside the BEP.

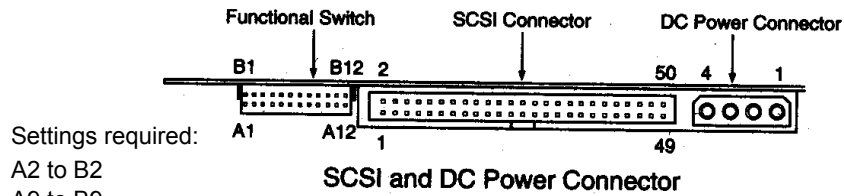

Figure 8-67 MO Drive Removal

- 8.) Carefully slide the MO Drive out from the front of the BEP.

8-5-13-4 MO Drive Installation Procedure

Note: Before installing the new MO Drive, make sure the MO Drive jumper settings are shorted as shown below:



- 1.) *For BEP1:*
Assemble the black *plastic* slides provided with the MO drive, or use those from the drive previously removed.
For BEP2:
Use the *metal* tracks provided with the MO drive, or use those from the drive previously removed. See note below.
- 2) Carefully slide the MO Drive into the front of the BEP (refer to [Figure 8-67](#) on page 8-80). For BEP2 systems, secure the MO Drive in position with the four screws (two on each side).
- 3) From the BEP rear, remove the empty panel (2nd from the top) and insert the SCSI card see [SCSI Board Installation Procedure](#) on page 8 - 73.
- 4) Connect the data cable between the SCSI card and the rear of the MO Drive.
- 5.) Connect the power cable to the rear of the MO Drive. Make sure that Pin 1 is aligned with the red line on the flat cable.
- 6.) If applicable, install the octopus card holder as described in the [BEP2 - Octopus Card Holder Installation Procedure](#) on page 8 - 68.
- 7) Install the BEP left and right side covers, as described in the [BEP2 - Side Cover Removal Procedure](#) on page 8 - 66.

Note: If this MO Drive installation is newly-installed hardware for this system, the kit should have been provided with a set of sliders (one set for BEP1 and one for BEP2), and also a front cover for BEP2. Refer also to the SCSI card installation instructions in the [SCSI Board Installation Procedure](#) on page 8 - 73.

8-5-14 ECG Module Replacement Procedure

NOTE: In this section, the replacement procedure for an ECG Module for BEP1/BEP0 and BEP2 systems are provided in separate sub-sections.

8-5-14-1 Tools

Use the appropriate flat and Phillips-type screw drivers and a wire cutter.

8-5-14-2 Preparation

Shut down the Vivid™ 3 ultrasound unit, as described in [Chapter 3 - Installation](#).

When ordered as a spare part (P/N: 22556476), the ECG kit will include the following items:

P/N	Description	Quantity
2334537	Patient I/O Assy. Box	1
2552982	Internal Foot Switch Cable	1
2274035	Slider Left	1
2274036	Slider Right	1
280A0306	P.H.P Screw M3XL6	4
280P0003	Spring Washer Int. M3	4
2298089	ECG Adaptor to COM2 Cable	1
22771878	Purpose Gaskets 10 cm strip	1
2334537INS	ECG Module Replacement Instructions	1

8-5-14-3 BEP1 and BEP0 - ECG Module Removal Procedure

NOTE: BEP1 refers to a Pentium III-based BEP (earlier type).

- 1) Disconnect the mains AC power cable for the mains power wall outlet.
- 2) Remove the Vivid™ 3 left and right side covers - refer to the [Side Covers Removal Procedure](#) on page 8 - 4.
- 3.) Remove the Vivid™ 3 rear cover - refer to the [Rear Cover Removal Procedure](#) on page 8 - 7.
- 4) Disconnect all cables from the rear of the BEP.
- 5) Remove the BEP from the machine as described [Back End Processor Replacement Procedure](#) on page 8 - 58.
- 6) Remove both BEP side covers as described in the [BEP1 - Left and Right Side Cover Removal Procedure](#) on page 8 - 64.
- 7) Remove the BEP front cover as described in the [BEP1 - Front Cover Removal Procedure](#) on page 8 - 64.

- 8) Disconnect the power cable and COM2 cable from the rear of the ECG Module - see [Figure 8-68](#) below.

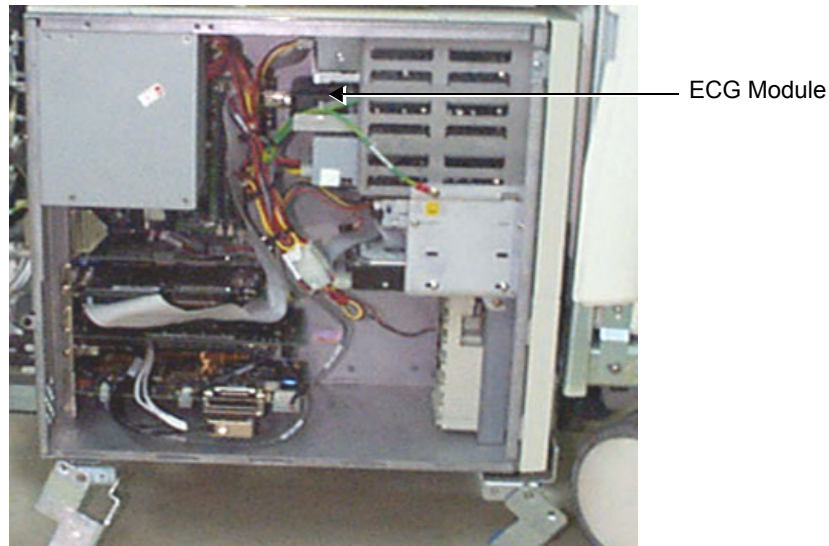

Figure 8-68 ECG Module - BEP1

- 9) Carefully slide out the ECG Module from the front of the BEP.

8-5-14-4 BEP1 and BEP0 - ECG Module Installation Procedure

NOTE: BEP1 refers to a Pentium III-based BEP (earlier type).

- 1) If necessary, assemble the side rails onto the new ECG Module as shown in [Figure 8-69](#) below.

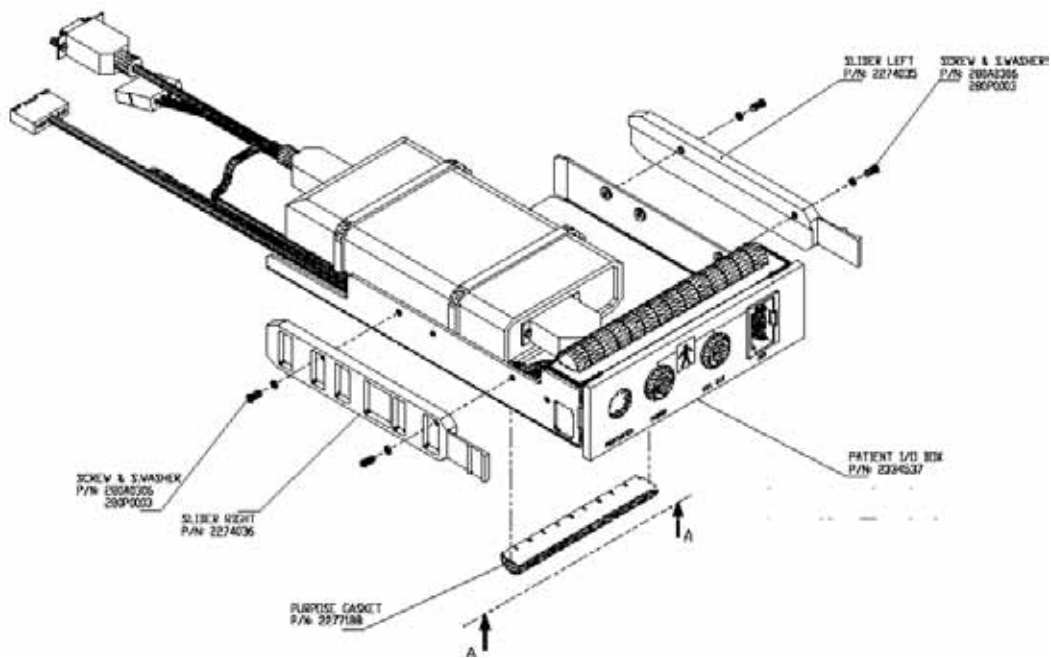

Figure 8-69 ECG Module with Rail Attached

- Note:** In the event that screws or side rails are misplaced, one can use the screws, slides, and rails from the ECG Module that was removed from the BEP.
- 2) Remove the protective layer from the Purpose Gaskets, and affix the gaskets in line with the existing Purpose Gaskets on the bottom of the new ECG module.
 - 3) Slide the new ECG Module into the front of the BEP, pushing it in until it is properly aligned with the other modules at the front of BEP.

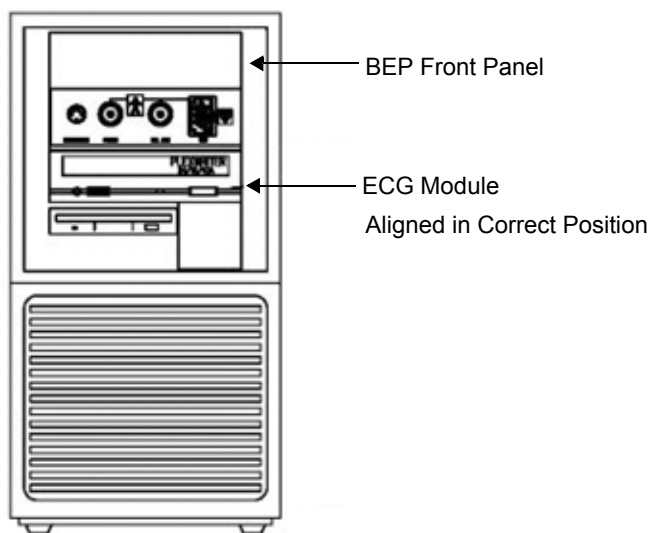

Figure 8-70 New ECG Module inside BEP1

- 4) Reconnect the power cable and the COM 2 cable to the rear of the new ECG Module.
- 5) Replace the BEP Front Panel and secure it with the screw that was previously removed.
- 6) Carefully return the BEP to its original position.
- 7) Return both BEP side covers as described in the [BEP1 - Left and Right Side Cover Removal Procedure](#) on page 8 - 64.
- 8) Push the BEP as far to the right as possible; tighten first the *left lower* bracket, then the *right lower* bracket, and finally the *upper left* side bracket. Use two screws to fasten each bracket securely.
- 9) Reconnect all cables at the rear of the BEP.
- 10) Return the Vivid™ 3 rear cover to its original position - see [Rear Cover Replacement Procedures](#) on page 8 - 7.
- 11) Return the Vivid™ 3 side covers, as described in [Side Covers Installation Procedure](#) on page 8 - 4.
- 12) Reconnect the mains AC power cable from the wall outlet.
- 13) Turn ON the main circuit breaker located on rear of the Vivid™ 3.
- 14) Turn ON the Vivid™ 3 by pressing the ON/OFF button on the Control Console.

8-5-14-5 BEP2 - ECG Module Removal Procedure

NOTE: BEP2 refers to a Pentium 4-based BEP (newer type).

- 1) Disconnect the mains AC power cable for the mains power wall outlet.
- 2) Remove the Vivid™ 3 left and right side covers - refer to the [Side Covers Removal Procedure](#) on page 8 - 4.
- 3.) Remove the Vivid™ 3 rear cover - refer to the [Rear Cover Removal Procedure](#) on page 8 - 7.
- 4) Disconnect all cables from the rear of the BEP.
- 5) Remove the BEP from the machine as described [Back End Processor Replacement Procedure](#) on page 8 - 58.
- 6) Remove both BEP side covers as described in the [BEP2 - Side Cover Removal Procedure](#) on page 8 - 66.
- 7) Remove the BEP front cover as described in the [BEP2 - Front Cover Removal Procedure](#) on page 8 - 66. A left view of the exposed BEP showing the location of the ECG module is seen in [Figure 8-71](#) below:



Figure 8-71 ECG Module - BEP2

- 8) Remove the four screws that secure the ECG Module in position (two from each side of the exposed BEP as shown in [Figure 8-72](#) on page 8-86).

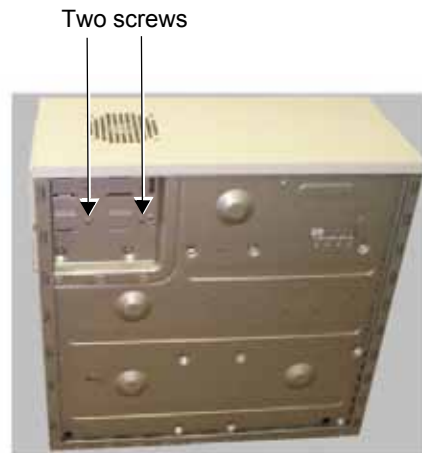

Figure 8-72 ECG Module Removal- BEP2

- 9) Disconnect the footswitch cable from the KB Controller card.
- 10.)Disconnect the COM2 cable from the rear of the ECG Module.
- 11) Carefully slide out the ECG Module from the front of the BEP.

8-5-14-6 BEP2 - ECG Module Installation Procedure

NOTE: BEP2 refers to a Pentium 4-based BEP (newer type).

- 1.) Slide the new ECG Module into the front of the BEP, pushing it in until it aligns with other modules at the front of BEP.
- 2) Secure the ECG Module with four screws, two from each side of the BEP (see [Figure 8-72](#), above).
- 3.) Replace the BEP Front Panel and secure it with the two screws previously removed.



Figure 8-73 ECG Module inside BEP2

- 4) Reconnect the power cable and the COM 2 cable to the rear of the new ECG Module.
- 5) Install the BEP left and right side covers, as described in the [BEP2 - Side Cover Installation Procedure](#) on page 8 - 66.
- 6.) Carefully return the BEP to its original location and secure all brackets by tightening the screws.
- 7) Reconnect all cables at the rear of the BEP.
- 8) Return the Vivid™ 3 rear cover to its original position - see [Rear Cover Replacement Procedures](#) on page 8 - 7.
- 9) Return the Vivid™ 3 side covers, as described in the [Side Covers Installation Procedure](#) on page 8 - 4.
- 10) Reconnect the mains AC power cable from the wall outlet.
- 11) Turn ON the main circuit breaker located on rear of the Vivid™ 3.
- 12) Turn ON the Vivid™ 3 by pressing the ON/OFF button on the Control Console.

8-5-15 PC-VIC Replacement Procedure

NOTE: This procedure is performed for systems with a BEP2 (Pentium 4-based BEP, newer type).

8-5-15-1 Tools

Use the appropriate flat and Phillips-type screw drivers and a wire cutter as indicated in the PC-VIC replacement procedure.

8-5-15-2 Preparation

Shut down the Vivid™ 3 ultrasound unit, as described in [Chapter 3 - Installation](#).

8-5-15-3 PC-VIC Removal Procedure

- 1) Remove the left cover, as described [Side Covers Removal Procedure](#) section, page 8-4.
- 2) Remove the BEP side cover as described in the [BEP2 - Side Cover Removal Procedure](#) on page 8 - 66.
- 3.) Remove the screw that holds the Ground cable and PC-VIC in position (as shown in [Figure 8-74](#)

below).

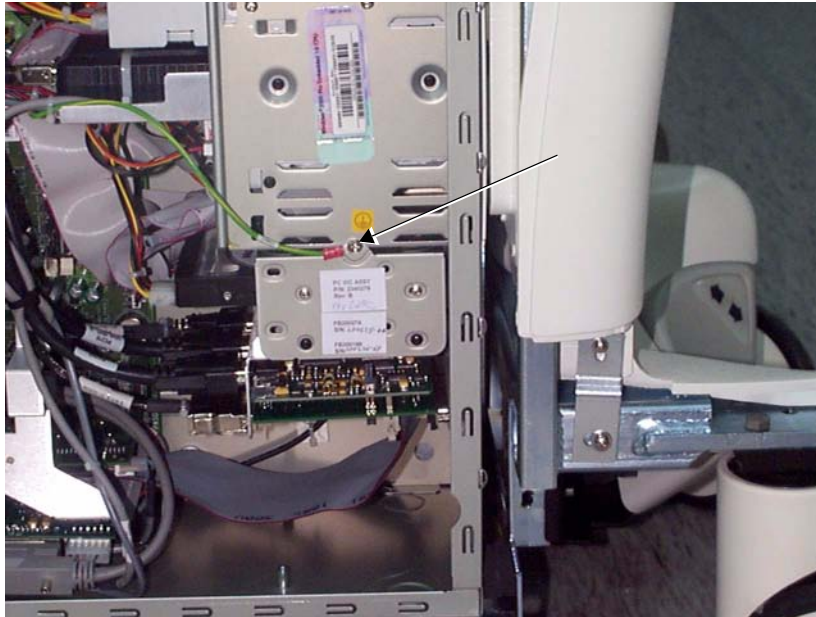

Figure 8-74 PC-VIC

- 4.) Carefully slide the PC-VIC out from the unit.
- 5.) Disconnect all the cables at the rear of the PC-VIC module and the hard disk.
- 6.) Remove the four screws (two on each side) from the side of the PC-VIC module holder as shown in [Figure 8-75](#) on page 8-88.



Figure 8-75 PC-VIC Removal

- 7.) Remove the PC-VIC.

8-5-15-4 PC-VIC Installation Procedure

- 1) Place a new PC-VIC in the PC-VIC module holder.
- 2) Return and tighten the four screws (two each side) on the side of the holder - refer to [Figure 8-75](#), above.
- 3.) Reconnect all the cables at the rear of the PC-VIC module and the hard disk.
- 4.) Carefully slide the PC-VIC into position in the same location as that of the removed PC-VIC.
- 5.) Return and tighten the screw that holds the PC-VIC in position (as shown in [Figure 8-74](#) on page 8-88).
- 6.) Connect the flat cable between the PC2IP and the PC-VIC.
- 7) Replace the BEP side cover as described in the [BEP2 - Side Cover Installation Procedure](#) on page 8 - 66.
- 8) Remove the Vivid™ 3 left cover, as described in the [Side Covers Installation Procedure](#) on page 8 - 4.

8-5-16 BEP2 Power Supply Replacement Procedure

NOTE: This procedure is performed for systems with a BEP2 (Pentium 4-based BEP, newer type).

8-5-16-1 Tools

Use the appropriate flat and Phillips-type screw drivers and a wire cutter as indicated in the BEP2 Power Supply replacement procedure.

8-5-16-2 Preparation

Shut down the Vivid™ 3 ultrasound unit, as described in [Chapter 3 - Installation](#). Voltage may exist in the system when a Plug & Scan is present. Ensure that a full shutdown of the system is performed, otherwise voltage might be present that can cause injury and/or damage.

8-5-16-3 BEP2 Power Supply Removal Procedure

- 1) Disconnect the mains AC power cable for the mains power wall outlet.
- 2) Remove the Vivid™ 3 left and right side covers - refer to the [Side Covers Removal Procedure](#) on page 8 - 4.
- 3.) Remove the Vivid™ 3 rear cover - refer to the [Rear Cover Removal Procedure](#) on page 8 - 7.
- 4) Remove the BEP2 from the Vivid™ 3 ultrasound unit, as follows:
 - a.) Remove the two screws of *upper* BEP bracket, see [Figure 8-54](#) on page 8-59.
 - b.) Remove the screws of the *lower left* and *right* BEP brackets ([Figure 8-54](#)).
 - c.) Disconnect all the cables from rear of the BEP, leaving the HASP key (option plug) connected.
 - d.) Completely remove the BEP2 from the unit.
- 5) Remove the BEP2 side covers, as described in the [BEP2 - Side Cover Removal Procedure](#) on page 8 - 66. Refer also to [Figure 8-76](#) below.



Figure 8-76 BEP2 with Side Cover Removed

- 6.) Remove the one screw, as shown in [Figure 8-76](#).
- 7.) Remove the BEP front cover as described in the [BEP2 - Front Cover Removal Procedure](#) on page 8 - 66.

- 8.) From the rear of the BEP2, remove the four screws that fasten the power supply in position on the BEP, as shown in [Figure 8-77](#).

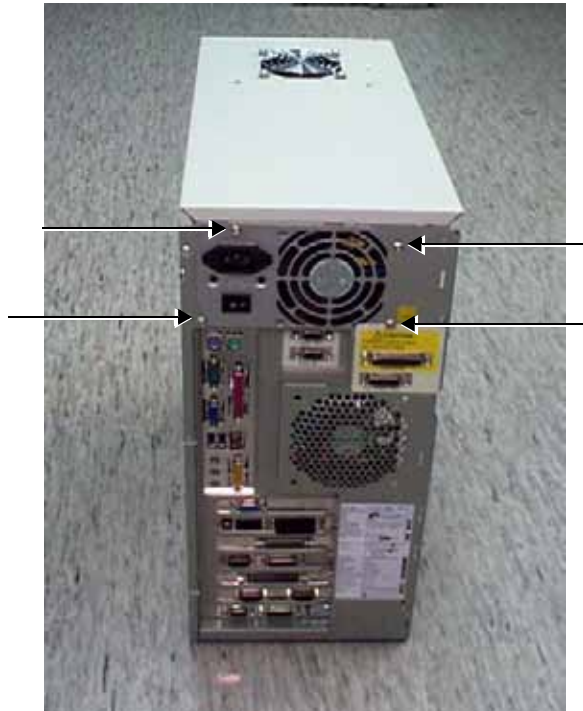

Figure 8-77 BEP2 Rear View

Note: For the next steps, it is recommended to carefully lie the BEP2 on its side, to provide easier access.

- 9.) Cut any cable ties holding the power supply cable in place, as shown in [Figure 8-78](#) below.



Figure 8-78 BEP2 Power Supply and Cable Ties

10.) Gently slide the power supply a short distance backwards (away from the BEP casing), while tilting it downwards and pulling it to the side.

NOTE: For clarification, the numbers appearing in square brackets in the following steps correspond to the numbers shown in the illustration of the BEP2 Power Supply and cable connectors in [Figure 8-81](#) below.

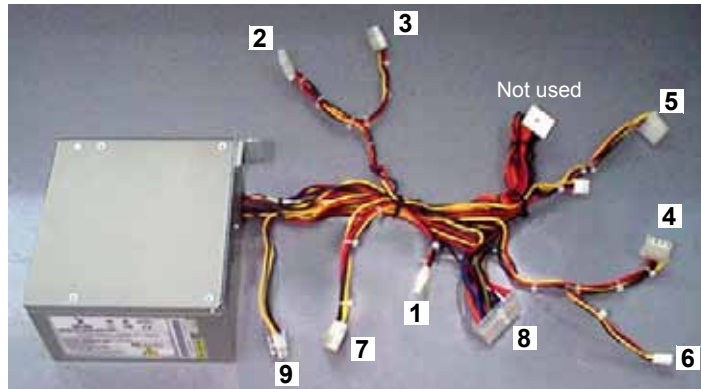

Cable Connections	
1	ECG
2	MOD
3	CD-RW
4	Hard Disk
5	PC-VIC
6	Floppy Disk
7	BEP rear
8	Motherboard (beside ECG)
9	Motherboard (beside CPU)

Figure 8-79 BEP2 Power Supply with Cable Loom and Connectors

- 11.) Carefully remove the ECG Module from the front of the BEP, sliding it out and disconnecting the power cable [1] from the rear of the ECG Module. (Refer to the [BEP2 - ECG Module Removal Procedure](#) on page 8 - 85).
- 12.) Disconnect the power cables from the media drives (MOD [2] and CD-RW [3]).
- 13.) Remove the screw that fastens the Ground cable and PC-VIC in position, as shown in [Figure 8-80](#) below.

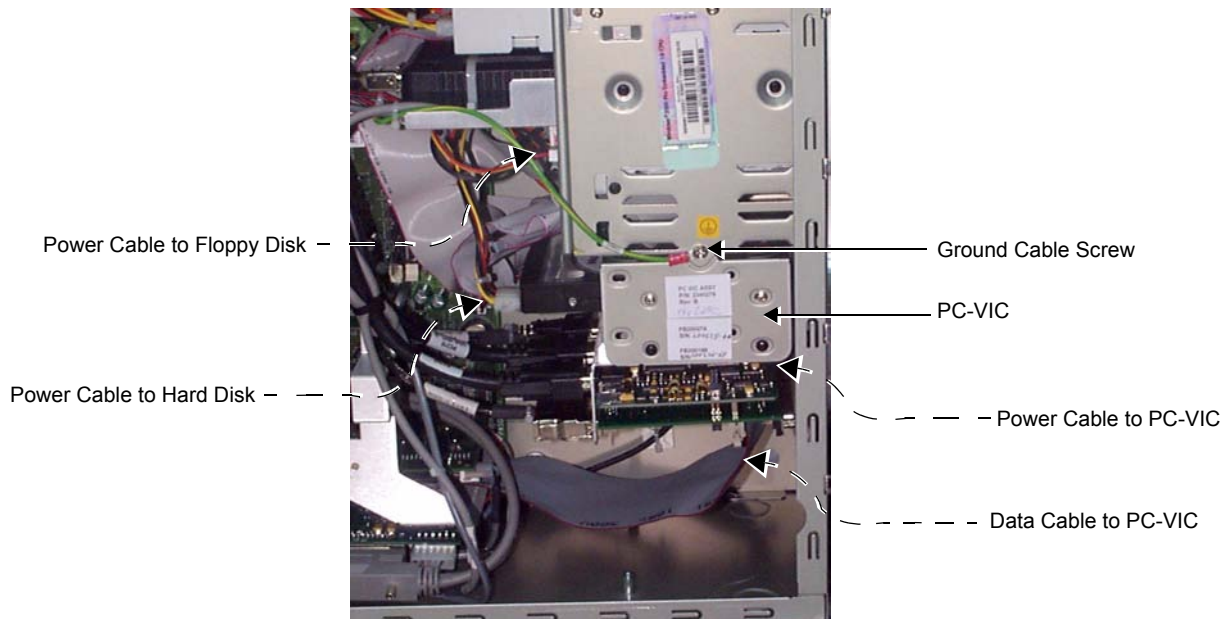

Figure 8-80 Disconnecting Cables

- 14.) Disconnect the power cable from the Hard Disk (labelled [4] in [Figure 8-79](#)); refer also to [Figure 8-80](#).
- 15.) Disconnect the data cable from the PC-VIC (refer to [Figure 8-80](#), above).
- 16.) Slide the PC-VIC & hard disk out sufficiently to be able to cut any cable ties and disconnect the power cable (labelled [5] in [Figure 8-79](#)) from the PC-VIC; refer also to [Figure 8-80](#), above.

- 17.) Disconnect the power cable from the Floppy Disk (labelled [6] in [Figure 8-79](#)); refer also to [Figure 8-80](#), above.
- 18.) Disconnect the mains power cable (4-pin flat connector [7] - Part No. 2252981) from the rear of the BEP, cutting any cable ties as necessary.
- 19.) Disconnect the mains power cable [8] from the motherboard (beside the ECG location).
- 20.) Gently slide the power supply further downwards and then out of the BEP casing sufficiently to be able to cut any remaining cable ties.
- 21.) Remove the power supply from the BEP, together with the attached cable loom, as shown in [Figure 8-81](#) below.
- 22.) Disconnect the 4-pin external connector [9] from the motherboard (beside the CPU).

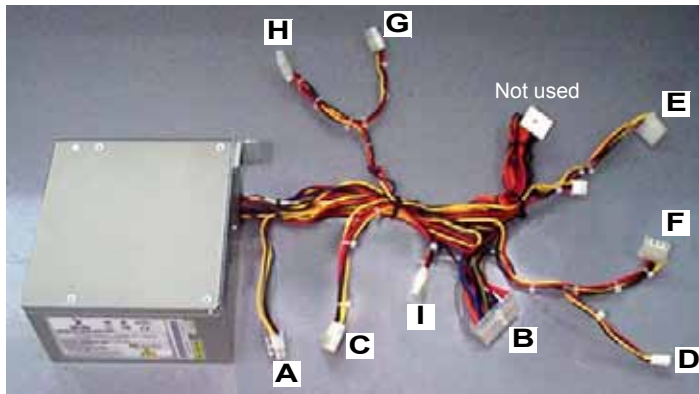

Figure 8-81 Removing the BEP2 Power Supply with Cable Loom and Connectors

8-5-16-4 BEP2 Power Supply Installation Procedure

Note: When performing this procedure, it is recommended to work with the BEP2 lying on its side (as shown in [Figure 8-78](#) on page 8-91), to provide easier access.

NOTE: For clarification, the letters appearing in square brackets in the following steps correspond to the letters shown in the illustration of the BEP2 Power Supply and cable connectors in [Figure 8-82](#) below.



Cable Connections	
A	Motherboard (beside CPU)
B	Motherboard (beside ECG)
C	BEP rear
D	Floppy Disk
E	PC-VIC
F	Hard Disk
G	CD-RW
H	MOD
I	ECG

Figure 8-82 BEP2 Power Supply with Cable Loom and Connectors

- 1.) Route the cable loom down into the cavity of the BEP casing (placing the cable labelled [E] in [Figure 8-82](#) at the front of the loom) and arrange each of the cables in the approximate position. Carefully feed the cable connectors underneath the data cables.
- 2.) Holding the new BEP2 power supply in one hand, connect the 4-pin external connector [A] to the motherboard (beside the CPU).
- 3.) Slide the power supply into the BEP power supply location (see [Figure 8-83](#) below) and push the metal stabilizing bracket (located on the side of the power supply) *downwards* to hold the power supply in position.

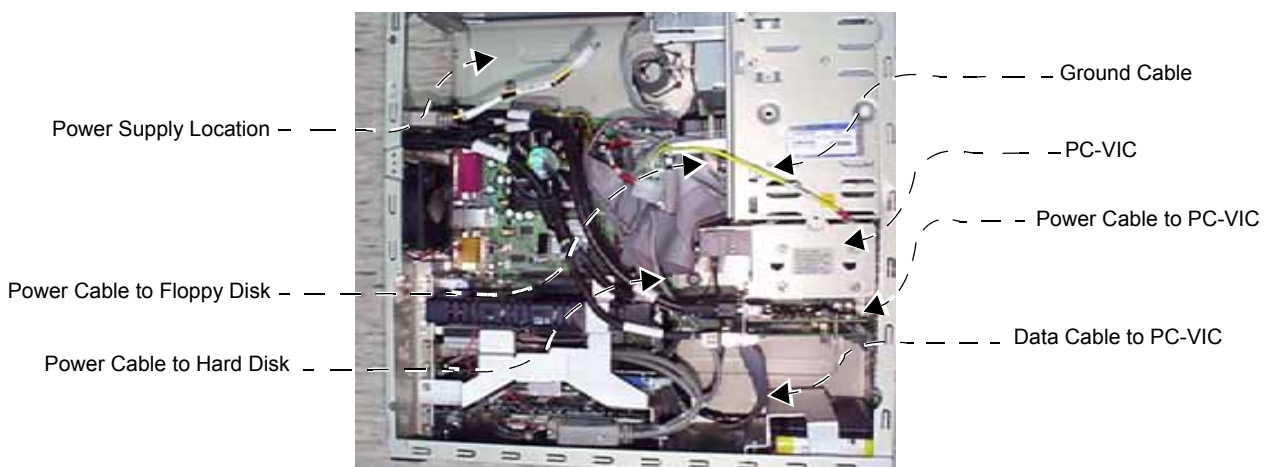

Figure 8-83 BEP2 Power Supply Location

- 4.) Re-connect the mains power cable [B] to the motherboard (beside the ECG location).
- 5.) Re-connect the mains power cable (4-pin flat connector [C] - Part No. 2252981) to the rear of the BEP, and fasten with cable ties.
- 6.) Re-connect the power cable to the Floppy Disk (labelled [D] in [Figure 8-82](#)); refer also to [Figure 8-83](#), above.
- 7.) Slide the PC-VIC & hard disk out sufficiently to be able to re-connect the power cable (labelled [E] in [Figure 8-82](#)) to the PC-VIC; refer also to [Figure 8-83](#), above.
- 8.) Re-connect the data cable to the PC-VIC (see [Figure 8-83](#), above).
- 9.) Re-connect the power cable to the Hard Disk (labelled [F] in [Figure 8-82](#)); refer also to [Figure 8-83](#), above.
- 10.) Return the Ground cable and screw that fastens the PC-VIC in position, as shown in [Figure 8-80](#) on page 8-92.
- 11.) Re-connect the power cables to the media drives (and CD-RW [G]) and MOD [H] .
- 12.) Carefully place the ECG Module in the front of the BEP, sliding it into position and re-connecting the power cable [I] to the rear of the ECG Module. (Refer to the [BEP2 - ECG Module Installation Procedure](#) on page 8 - 86).
- 13.) Gently slide the power supply up into the final position in the BEP casing.
- 14.) Check that all cable connections are secured firmly and fasten with additional cable ties, as necessary.

NOTE: *Make sure that all data cables, memory boards, etc. are securely in position and that nothing has erroneously become disconnected during the power supply removal procedure.*

- 15.) Stand the BEP2 upright.
- 16.) At the rear of the BEP2, return and loosely tighten the four screws that fasten the power supply in position on the BEP, as shown in [Figure 8-77](#) on page 8-91.
- 17.) Return the BEP front cover as described in the [BEP2 - Front Cover Installation Procedure](#) on page 8 - 68.
- 18.) Return the one screw previously removed from the top of the side cover, as shown in [Figure 8-76](#) on page 8-90.
- 19.) Fully tighten the four screws at the rear of the BEP (refer to [step 16](#)) to secure the power supply firmly in position.
- 20.) Return the BEP2 side covers, as described in the [BEP2 - Side Cover Installation Procedure](#) on page 8 - 66.
- 21.) Carefully return the BEP2 to the original position on the machine chassis, and proceed as follows:
 - a.) Re-connect all the cables on the rear of the BEP (refer to the step-by-step instructions provided in [Back End Processor Installation Procedure](#) on page 8 - 60).
 - b.) Return the screws of the *lower* left and *right* BEP brackets see [Figure 8-54](#) on page 8-59.
 - a.) Return the two screws of *upper* BEP bracket ([Figure 8-54](#)).
- 22.) Replace the Vivid™ 3 rear cover - refer to the [Rear Cover Installation Procedure](#) on page 8 - 7.
- 23.) Remove the Vivid™ 3 left and right side covers - refer to the [Side Covers Installation Procedure](#) on page 8 - 4.
- 24.) Re-connect the mains AC power cable for the mains power wall outlet.
- 25.) Turn ON the main circuit breaker located on rear of the Vivid™ 3.
- 26.) Turn ON the Vivid™ 3 by pressing the ON/OFF button on the Control Console.

8-5-17 Hard Disk Replacement Procedure

8-5-17-1 Tools

Use the appropriate flat and Phillips-type screw drivers and a wire cutter as indicated in the Hard Disk replacement procedure.

8-5-17-2 Preparation

Shut down the Vivid™ 3 ultrasound unit, as described in [Chapter 3 - Installation](#).

8-5-17-3 Hard Disk Removal Procedure

- 1) Remove the left cover, as described [Side Covers Removal Procedure](#) section, page 8-4.
- 2.) Remove the BEP side cover as described in the appropriate procedure: [BEP1 - Left and Right Side Cover Removal Procedure](#) on page 8 - 64, or [BEP2 - Side Cover Removal Procedure](#) on page 8 - 66.
- 3.) Remove the screw that holds the hard disk module in position (as shown in [Figure 8-74](#) below).



Figure 8-84 Hard Disk Removal 1

- 4) Carefully slide the module out from the unit.
- 5) Remove each of the four screws (two on each side), as shown in [Figure 8-85](#) on page 8-97.

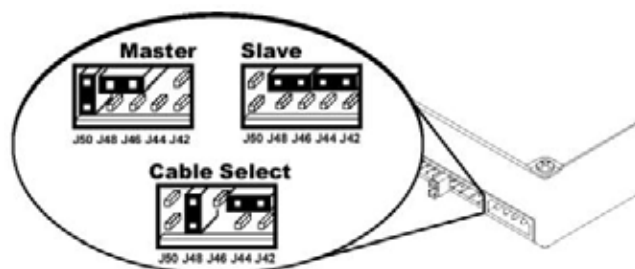

Figure 8-85 Hard Disk Removal 2

- 6.) Disconnect all the cables at the rear of the hard disk.
- 7.) Remove the hard disk.

8-5-17-4 Hard Disk Installation Procedure

Note: Before installing a new hard disk, make sure the jumper settings are as shown below:



Rear View of Hard Drive / Jumper Detail

- 1) Place the new hard disk in position in the hard disk module holder.
- 2.) Reconnect all the cables at the rear of the hard disk.
- 3) Fasten each of the four screws (two on each side), as shown in [Figure 8-85](#) on page 8-97.
- 4) Carefully slide the module holder into position in the unit.
- 5) Return and fasten the screw that holds the hard disk module in position (as shown in [Figure 8-74](#) on page 8-88)

- 6) Install the BEP side cover, as described in the appropriate procedure:
[BEP1 - Left and Right Side Cover Removal Procedure](#) on page 8 - 64, or [BEP2 - Side Cover Installation Procedure](#) on page 8 - 66.
- 7) Return the Vivid™ 3 left cover, as described in the [Side Covers Installation Procedure](#) on page 8 - 4.

Note: When a new hard disk arrives from the manufacturer, usually it is partitioned and ready for software installation.
Refer to [Software Loading](#) on page 8 - 121 for software installation instructions .

Section 8-6 Lower Section Components Replacement

8-6-1 AC Distribution Box Replacement Procedure

8-6-1-1 Tools

Use the appropriate flat and Phillips-type screw drivers and a wire cutter as indicated in the AC Distribution Box replacement procedure.

8-6-1-2 Preparation

Shut down the Vivid™ 3 ultrasound unit, as described in [Chapter 3 - Installation](#).

8-6-1-3 AC Distribution Box Removal Procedure

- 1) Remove the Vivid™ 3 left, right and rear covers, as described in the [Side Covers Removal Procedure](#) on page 8 - 4, and [Rear Cover Removal Procedure](#) on page 8 - 7.
- 2) Unplug all the internal cables from the AC Distribution Box and the voltage setting plugs at Jumper1 and Jumper2.
- 3) Unscrew the Ground cable located at the top-right corner of the AC Distribution Box.
- 4) Remove the two screws that are located on the lower bracket of the AC Distribution Box.

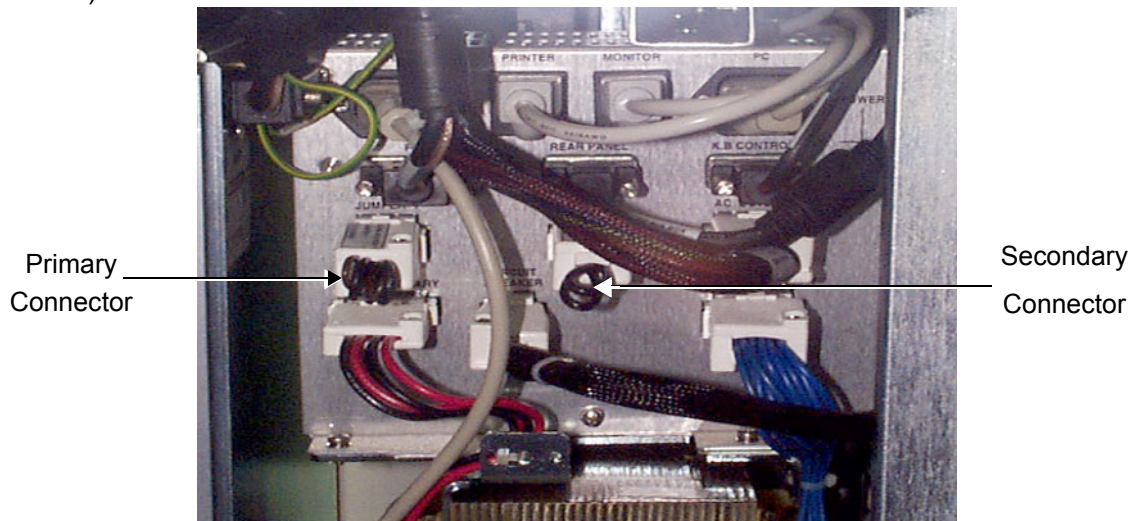

Figure 8-86 Lower Bracket of the AC Distribution Box

- 5) Gently pull the AC Distribution Box towards you, pulling it out through the rear of the machine.

8-6-1-4 AC Distribution Box Installation Procedure

- 1) Insert the AC Distribution Box through the rear of the machine and then push it into its original position.
- 2) Fasten the AC Distribution Box using the two screws located in the lower bracket of the AC Distribution Box.
- 3) Tighten the screw that connects the Ground cable to the AC Distribution Box.
- 4) Plug in all the internal cables to the AC Distribution Box, including the voltage setting plugs at Jumper1 and Jumper2.
- 5) Install the rear, left and right covers, as described in the [Rear Cover Installation Procedure](#) on page 8 - 7 and the [Side Covers Installation Procedure](#) on page 8 - 4.

8-6-2 AC Input Box Replacement Procedure

8-6-2-1 Tools

Use the appropriate flat and Phillips-type screw drivers and a wire cutter as indicated in the AC Input Box replacement procedure.

8-6-2-2 Preparation

Shut down the Vivid™ 3 ultrasound unit, as described in [Chapter 3 - Installation](#).

8-6-2-3 AC Input Box Removal Procedure

- 1) Unplug the AC line power cable.
- 2) Remove the Vivid™ 3 left, right and rear covers, as described in the [Side Covers Removal Procedure](#) on page 8 - 4, and the [Rear Cover Removal Procedure](#) on page 8 - 7.
- 3) Unplug the internal power cable from the AC Distribution Box.
- 4) Unscrew the Ground cable from the AC Distribution Box.
- 5) Remove the two screws on both the *left* and the *right* sides that secure the AC Input Box to the chassis.

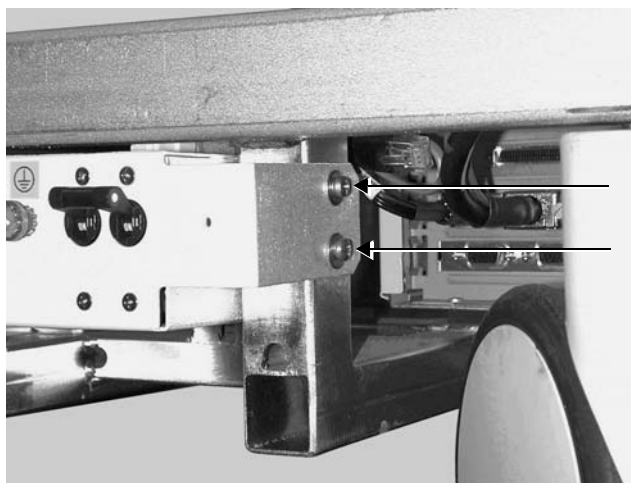

Figure 8-87 AC Input Box Screws

- 6) Remove the AC Input Box.

8-6-2-4 AC Input Box Installation Procedure

- 1) Return the AC Input Box to its original position.
- 2) Tighten the two screws on both the *left* and the *right* sides that secure the AC Input Box to the chassis.
- 3) Tighten the screw that connects the Ground cable to the AC Distribution Box.
- 4) Reconnect the internal power cable to the AC Distribution Box.
- 5) Install the Vivid™ 3 rear, left and right covers, as described in the [Rear Cover Installation Procedure](#) on page 8 - 7 and the [Side Covers Installation Procedure](#) on page 8 - 4.

8-6-3 Keyboard or Monitor Cable Replacement Procedure

8-6-3-1 Tools

Use the appropriate flat and Phillips-type screw drivers, a wire cutter and the appropriate Allen keys as indicated in the keyboard or monitor cable replacement procedure.

8-6-3-2 Preparation

Shut down the Vivid™ 3 ultrasound unit, as described in [Chapter 3 - Installation](#).

8-6-3-3 Keyboard or Monitor Cable Removal Procedure

- 1) Remove the Vivid™ 3 left, right and rear covers, as described in the [Side Covers Removal Procedure](#) on page 8 - 4, and the [Rear Cover Removal Procedure](#) on page 8 - 7.
- 2) Use the front handle to raise the console to its highest position.
- 3) Locate the black cable track containing all the cables, at the back of the unit.
- 4) Open the track by hooking a thumb or finger under the right side of one of the tracks and pulling the side of the track. The track clicks open, enabling you to select the required cable.



Figure 8-88 Opening the Track

- 5) Disconnect both ends of the cable that is to be replaced.
- 6) Replace the cable, adding new ties to bind the cables together where necessary, and snap the track back to the closed position.

8-6-3-4 Keyboard or Monitor Cable Installation Procedure

- 1) Route the cables, adding new ties to bind the cables together where necessary.
- 2) Reconnect both ends of the cable that was replaced.
- 3) Close the track by pressing a thumb or finger on the left and right sides of each of the tracks and pushing the track until it snaps back to the closed position.
- 4) Replace the Vivid™ 3 rear, left and right covers, as described in the [Rear Cover Installation Procedure](#) on page 8 - 7 and the [Side Covers Installation Procedure](#) on page 8 - 4.

8-6-4 AC, BEP or FE Cable Replacement Procedure

Use the appropriate flat and Phillips-type screw drivers, a wire cutter, the appropriate Hex wrenches and the appropriate Allen keys as indicated in the cable replacement procedure.

8-6-4-1 Preparation

Shut down the Vivid™ 3 ultrasound unit, as described in [Chapter 3 - Installation](#).

8-6-4-2 AC, BEP or FE Cable Removal Procedure

- 1) Disconnect both ends of the required cable.
- 2) Open the plastic ties that hold the cables together.
- 3) Remove the required cable.

8-6-4-3 AC, BEP or FE Cable Installation Procedure

- 1) Route the required cable.
- 2) Connect both ends of the new cable.
- 3) Replace the ties and secure the cable in position.

8-6-5 Gas Spring Cable Replacement Procedure

Use the appropriate flat and Phillips-type screw drivers, a wire cutter and the appropriate open-wring wrenches as indicated in the gas spring cable replacement procedure.

8-6-5-1 Preparation

Shut down the Vivid™ 3 ultrasound unit, as described in [Chapter 3 - Installation](#).

8-6-5-2 Gas Spring Cable Removal Procedure

- 1) Pull out and remove the air filter, as described in the [Front Cover Removal Procedure](#) on page 8 - 5.
- 2) Remove the Vivid™ 3 side covers and the rear cover, as described in the [Side Covers Removal Procedure](#) on page 8 - 4 and in the [Rear Cover Removal Procedure](#) on page 8 - 7.
- 3) Remove the front end crate, as described in the [Front End Crate Removal Procedure](#) on page 8 - 50.
- 4) Raise the control console to its *maximum* height.
- 5) Remove the bottom keyboard cover, as described in the [Bottom Keyboard Cover Removal Procedure](#) on page 8 - 14.
- 6) Cut all the cable ties to free the required cable.
- 7) Remove the securing screw from the cable holder located on the gas spring rod.
- 8) Turn the cable holder to free the cable end sleeve, and then remove the cable end stopper from the trigger arm.
- 9) Loosen the securing nut located near the release handle underneath the keyboard, and then completely release the adjustable sleeve.

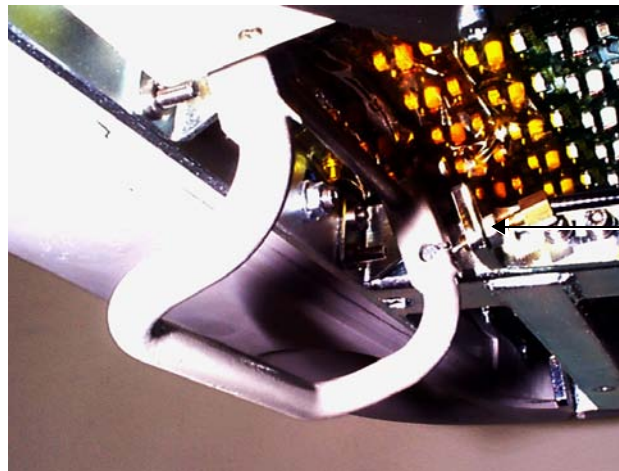

Figure 8-89 Release Handle

- 10) Remove the cable end stopper from the release handle.
- 11) Remove the gas spring release cable. Before removing the cable, pay attention to its path inside the machine, and the position of each of its parts.

8-6-5-3 Gas Spring Cable Installation Procedure

- 1) Raise the control console to its *maximum* height.
- 2) Route the gas spring cable along its original path in the machine. The end of the cable with the adjustable sleeve should be next to the release handle underneath the keyboard; the other end of the cable should be next to the lower end of the gas spring.
- 3) Fit the cable end stopper on the trigger arm.
- 4) Fit the groove of the cable end sleeve on the hinge of the gas spring head.
- 5) Turn the cable holder over the cable end sleeve, and then fasten it with the securing screw.
- 6) Insert the other cable end stopper into the release handle located underneath the keyboard, and then insert the wire into the slot and screw in the cable adjustment sleeve.
- 7) Adjust the securing nut so that there is no backlash of the release handle, and secure the adjustment with the nut.
- 8) Using the release handle, lower and raise the control console several times to verify its proper operation.
- 9) Fasten the cables to the machine with cable ties (at the original positions).
- 10) Return the front end crate to its original position, as described in the [Front End Crate Installation Procedure](#) on page 8 - 51.
- 11) Replace the Vivid™ 3 rear, left and right covers, as described in the [Rear Cover Installation Procedure](#) on page 8 - 7 and [Side Covers Installation Procedure](#) section, page 8-4.
- 12) Raise the control console to its *maximum* height, and then replace the bottom keyboard cover, as described in the [Bottom Keyboard Cover Installation Procedure](#) on page 8 - 15.
- 13) Insert the air filter in its original location, as shown in [Figure 8-3](#) on page 8-5.

Note: It is recommended to clean the filter before returning it to its original location, as described in [Chapter 10 - Periodic Maintenance](#).

- 14) Verify that the gas spring release handle is functioning correctly.

8-6-6 Up/Down Handle Replacement Procedure

NOTE: This section describes two removal procedures (for both the old [plastic] and new-type [metal] handles) and one installation procedure (for the new-type handle), as follows:

- Removal of the old-type (plastic) Up/Down Handle (Part No. 2260300) - see [Up/Down Handle Removal - Procedure 1](#), below.
- Removal of the new-type (metal) Up/Down Handle with support (Part No. 237002-2) - see [Up/Down Handle Removal Procedure 2](#) on page 8 - 107.
- Installation of the Up/Down Handle with support (Part No. 237002-2) - see [Up/Down Handle Replacement Procedure](#) on page 8 - 108.

8-6-6-1 Tools

Use the appropriate the Phillips-type screw drivers, as indicated in the up/down handle removal procedure.

8-6-6-2 Preparation

Shut down the Vivid™ 3 ultrasound unit, as described in [Chapter 3 - Installation](#).

8-6-6-3 Up/Down Handle Removal - Procedure 1

NOTE: This describes the procedure for removing the old-type (plastic) Up/Down Handle (Part No. 2260300).

- 1) Raise the control console to its *maximum* height. Remove the bottom keyboard cover, as described in the [Bottom Keyboard Cover Removal Procedure](#) on page 8 - 14.
- 2) Loosen and remove the nut on the M6 screw (see [Figure 8-90](#) below) that secures the up/down handle in position.

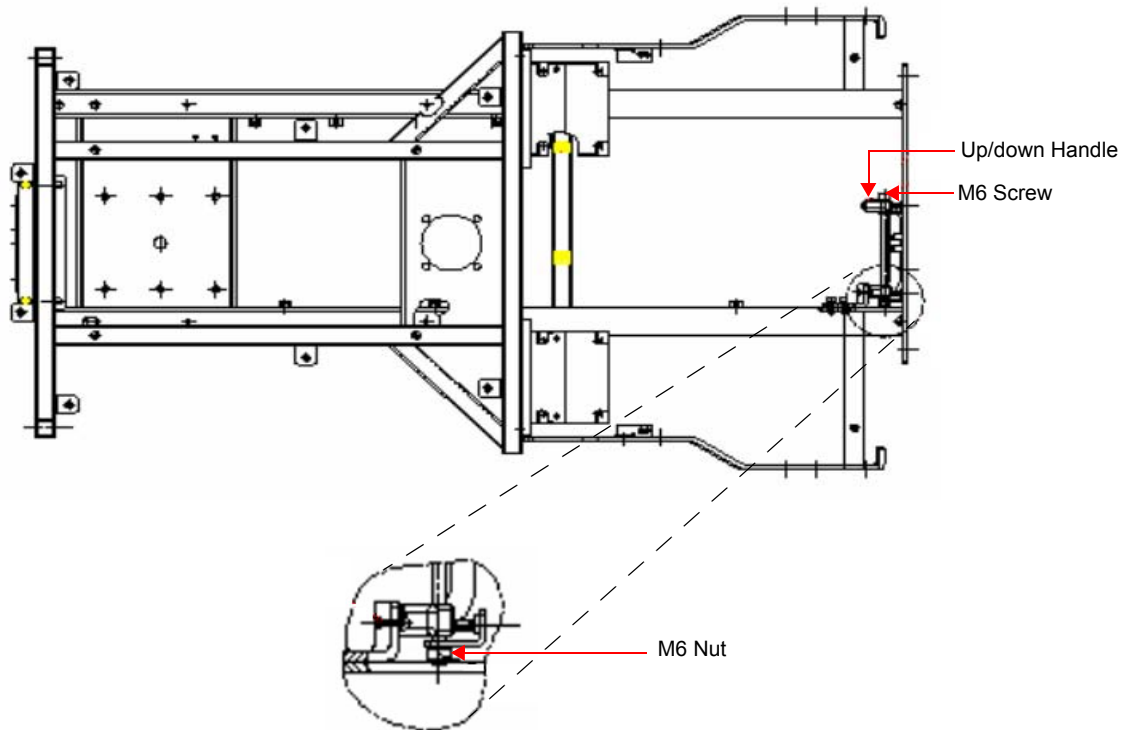

Figure 8-90 Up/Down Handle Securing Mechanism

- 3.) Extract the M6 screw from the up/down handle by sliding it out.
- 4.) Release the gas spring cable from the broken up/down handle - see [Figure 8-91](#) on page 8-107.
- 5.) Remove the broken up/down handle.

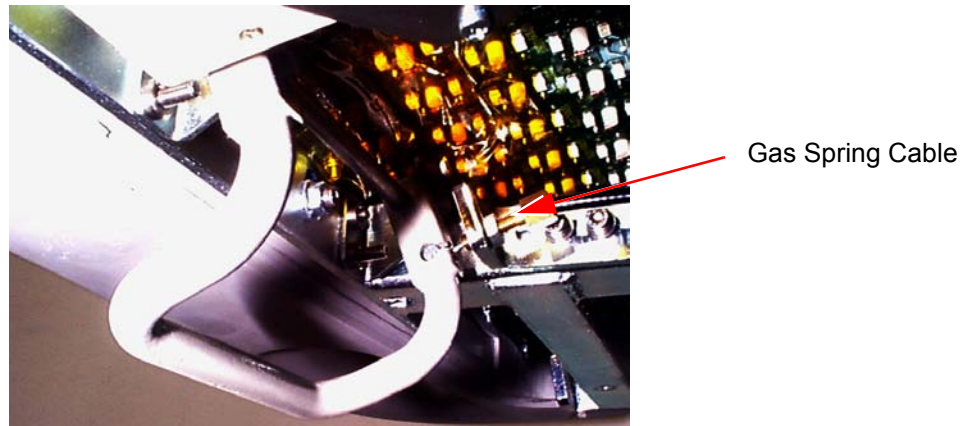

Figure 8-91 Gas Spring Release Handle

8-6-6-4 Up/Down Handle Removal Procedure 2

NOTE: This describes the procedure for removing the new-type (metal) Up/Down Handle (Part No. 237002-2).

- 1) Remove the bottom keyboard cover, as described in the [Bottom Keyboard Cover Removal Procedure](#) on page 8 - 14.
- 2) Remove the right and left probe holders, as described in the [Right and Left Probe Holders Removal Procedure](#) on page 8 - 23.
- 3) Remove the front handle from the console, as described in the [Front Handle Removal Procedure](#) on page 8 - 24.
- 4.) Release the gas spring cable by loosening the securing nut (shown in [Figure 8-92](#) below). Slide the cable out of the retaining bracket and slide the end of the cable out through the slot on the handle assembly (see below, and refer to the detail in [Figure 8-94](#) on page 8-109).

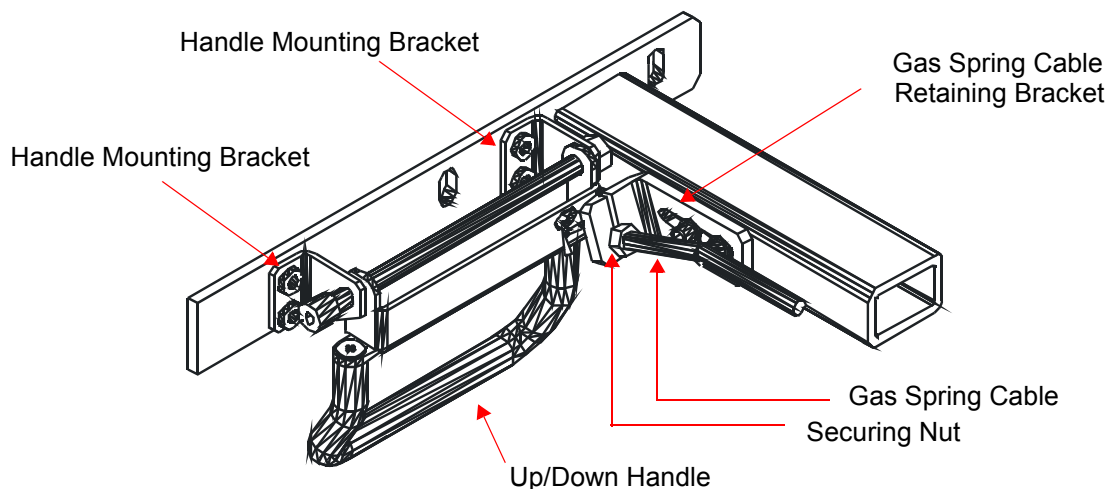

Figure 8-92 Up/Down Handle Securing Mechanism

- 5.) Remove the four screws (two short and two long) that secure the handle mounting brackets to the chassis (see [Figure 8-92](#), above) and remove the handle assembly. Refer also to [Figure 8-95](#) on page 8-109.
- 6.) Loosen and remove the M6 nut from the handle assembly axis screw - refer to [Figure 8-93](#) on page 8-108.
- 7.) Extract the axis screw from the handle assembly and remove the defective Up/Down handle.

8-6-6-5 Up/Down Handle Replacement Procedure

NOTE: This describes the procedure for installing the new-type (metal) Up/Down Handle (Part No. 237002-2).

- 1) Insert the M6 Axis screw through the screw hole in the first handle mounting bracket, through the two holes in the new metal Up/Down handle, then through the screw hole in the second bracket and into M6 nut, as shown in [Figure 8-93](#) below.

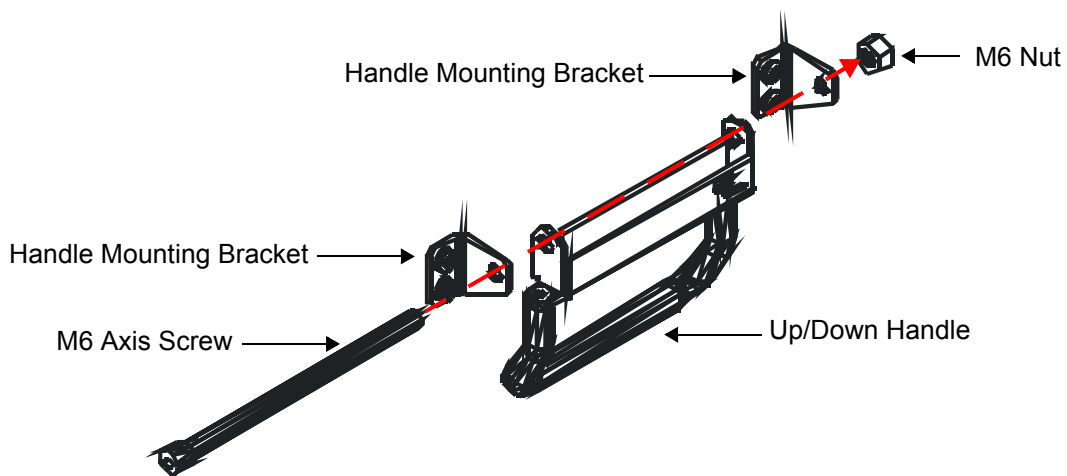

Figure 8-93 Fixing the Up/Down Handle to the Handle Mounting Brackets

- 2.) Tighten the M6 nut fully to secure the handle mounting brackets to the handle assembly.
- 3.) Insert the end of the gas spring cable through the slot on the gas spring cable retaining bracket and into the grooved hole on the Up/Down handle. Slide the end of the cable into the groove, carefully aligning the groove on the cable with that of the groove in the hole (see [Figure 8-94](#) below). Tighten the securing nut against the gas spring cable retaining bracket, to hold the cable securely in position.

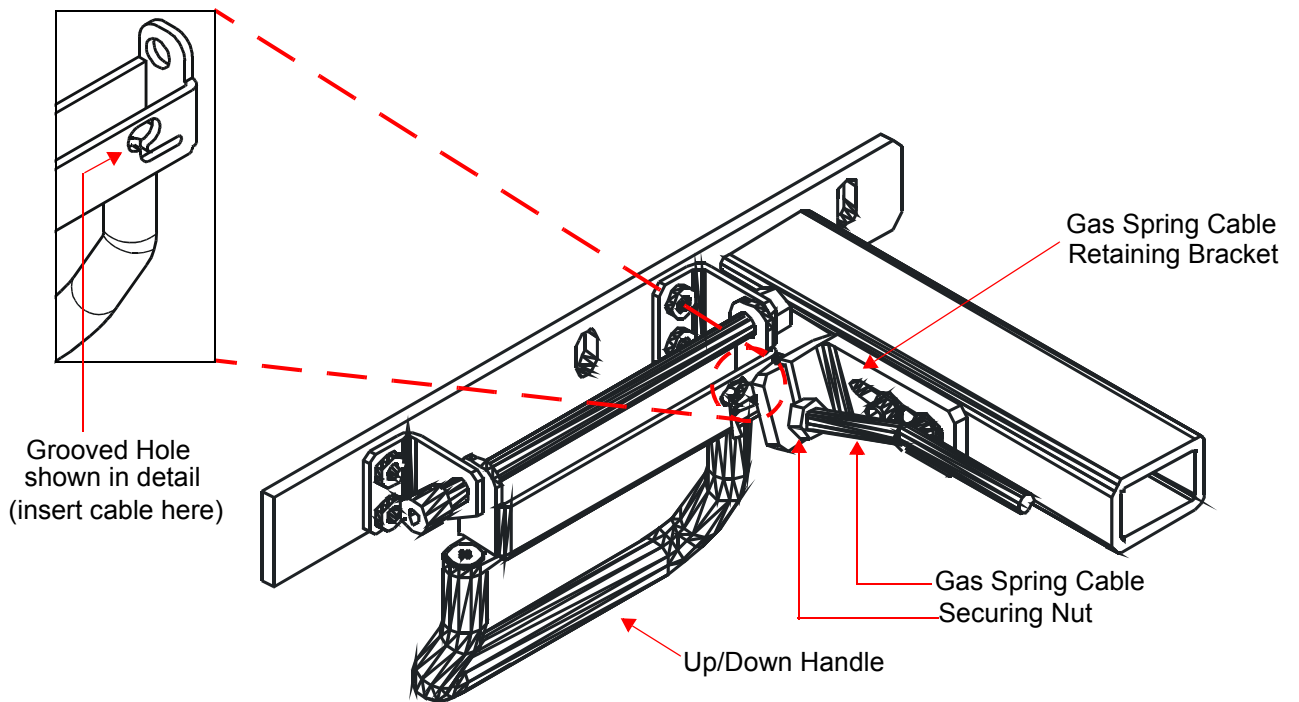

Figure 8-94 Fitting Gas Spring Cable to Up/Down Handle

- 4) Mount the handle mounting brackets onto the chassis using one long and one short screw for each bracket, as shown in [Figure 8-95](#). Tighten the screws to secure the brackets firmly in position.

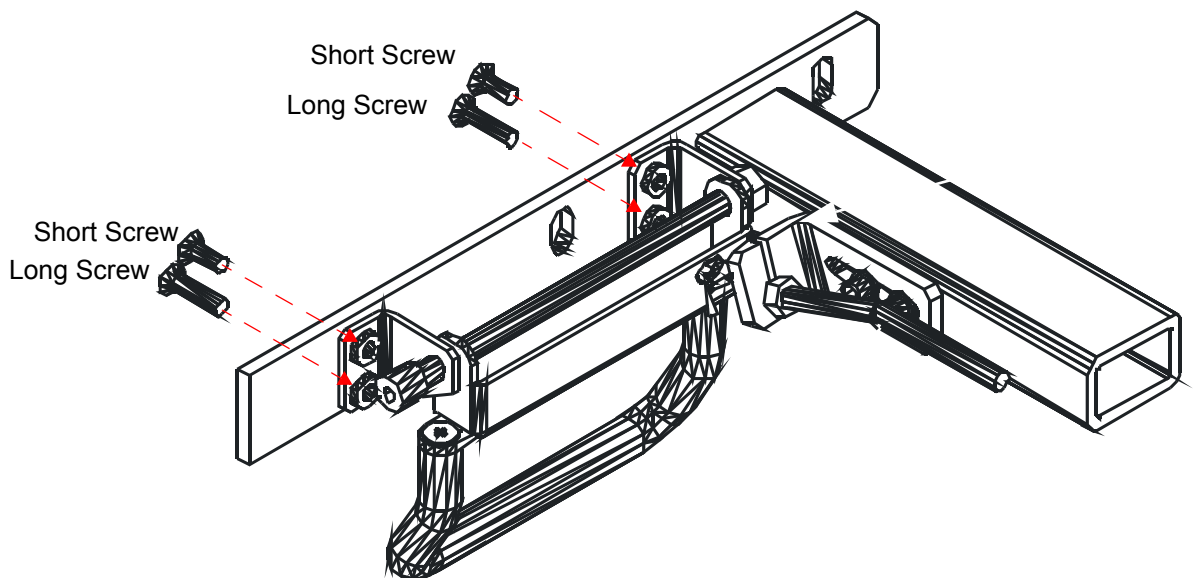

Figure 8-95 Mounting the Brackets onto the Chassis

- 5) Test the Up/Down handle to make sure the mechanism is operating properly and that the handle is fastened securely on the chassis.
- 6.) Return the front handle to the console and secure in position, as described in the [Front Handle Installation Procedure](#) on page 8 - 24
- 7) Return the right and left probe holders and secure in position, as described in the [Right and Left Probe Holders Installation Procedure](#) on page 8 - 23.
- 8) Return the bottom keyboard cover and secure in position, as described in the [Bottom Keyboard Cover Installation Procedure](#) on page 8 - 15.

8-6-7 Gas Spring Replacement Procedure

8-6-7-1 Tools

Use the appropriate flat and Phillips-type screw drivers, a wire cutter, the appropriate open-ring wrenches and a Hex M8x80mm screw as indicated in the gas spring replacement procedure.

8-6-7-2 Preparation

Shut down the Vivid™ 3 ultrasound unit, as described in [Chapter 3 - Installation](#).

8-6-7-3 Gas Spring Removal Procedure

- 1) Pull out and remove the air filter, as described in the [Front Cover Removal Procedure](#) on page 8 - 5.
- 2) Remove the Vivid™ 3 side covers and the rear cover, as described in the [Side Covers Removal Procedure](#) on page 8 - 4 and the [Rear Cover Removal Procedure](#) on page 8 - 7.
- 3) Remove the front end crate, as described in the [Front End Crate Removal Procedure](#) on page 8 - 50.
- 4) Lower the control console to its *minimum* height.
- 5) Remove the two screws located at the bottom of the left compartment of the control console, and then remove the white metal box from the compartment.

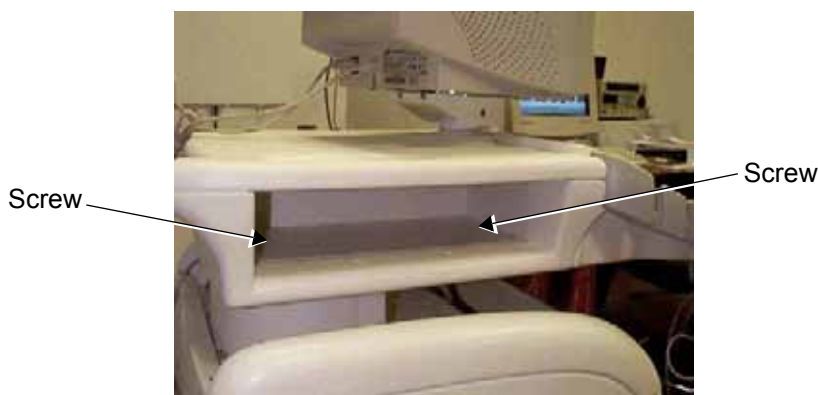

Figure 8-96 Left Compartment of the Control Console

- 6) Remove the securing screw from the cable holder located on the gas spring rod.

Note: In the following steps, all the gas spring components indicated by letters can be seen in [Figure 8-97](#) and [Figure 8-98](#) on page 8-112.

- 7) Turn the cable holder (B) to free the cable end sleeve (C) then remove the cable end stopper (D) from the trigger arm (E).



DANGER: Do not activate the trigger arm as this will cause the expansion of the gas spring and may cause damage and/or injury!

- 8) Remove the retaining washer (K) from the pin (L) at the lower end of the gas spring.
- 9) Insert the Hex M8x80mm screw in the appropriate hole to the left of the compartment at its base, and then tighten the screw until the pin (L) at the lower end of the gas spring is loose enough to be removed, and remove the pin.

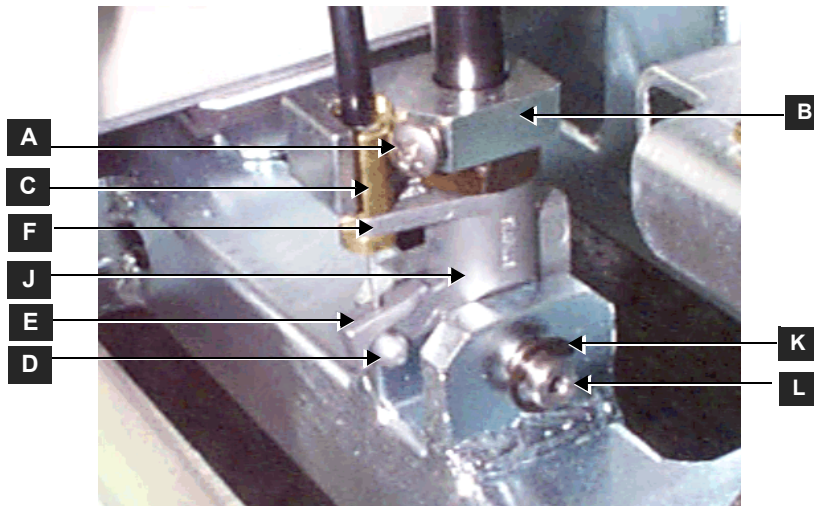

Figure 8-97 Gas Spring - Lower End and Cable

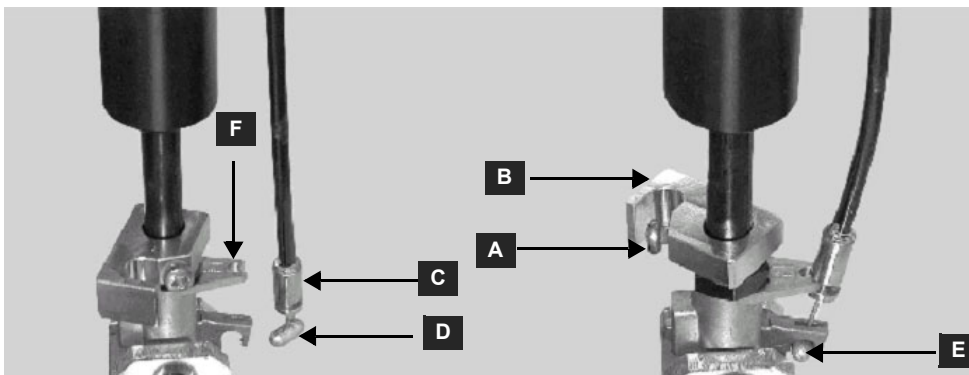

Figure 8-98 Gas Spring Lower End Cable - Close-up View

- 10) Remove the retaining washer (K) from the pin (L) at the lower end of the gas spring.
- 11) Insert the Hex M8x80mm screw in the appropriate hole to the left of the compartment at its base, and then tighten the screw until the pin (L) at the lower end of the gas spring is loose enough to be removed, and remove the pin.

Note: In the following step, the gas spring components indicated by letters can be seen in [Figure 8-99](#) on page 8-113.

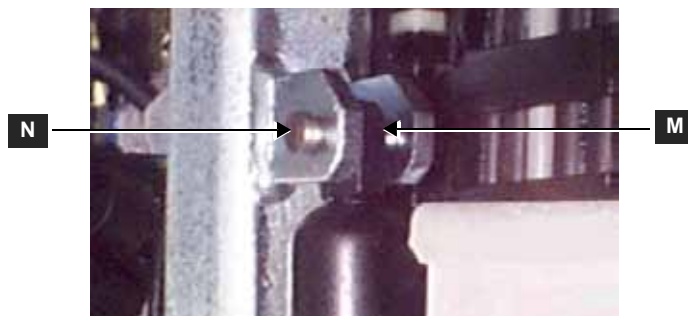

Figure 8-99 Gas Spring - Upper End

- 12) Remove the retaining washer (M) from the pin (N) at the upper end of the gas spring, and then remove the pin.
- 13) Carefully remove the gas spring.

8-6-7-4 Gas Spring Installation Procedure

Note: All the gas spring components indicated by letters in the following steps can be seen in [Figure 8-99](#), above and [Figure 8-97](#) and [Figure 8-98](#) on page 8-112.



DANGER: Do not activate the trigger arm as this will cause the expansion of the gas spring and may cause damage and/or injury!

- 1) Return the gas spring to its original position.
- 2) Insert the upper pin (N) and secure it with the retaining washer (M). You may have to adjust the M8x80mm screw before inserting the pin.
- 3) Insert the lower pin (L) and secure it with the retaining washer (K). You may have to adjust the M8x80mm screw before inserting the pin.
- 4) Fit the cable end stopper (D) on to the trigger arm (E).
- 5) Fit the groove of the cable end sleeve (C) on the hinge (F) of the gas spring head.
- 6) Turn the cable holder (B) over the cable end sleeve (C), and then fasten it with the securing screw (A).
- 7) Remove the Hex M8 screw from the compartment.
- 8) Using the release handle, lower and raise the control console several times to verify its proper operation.
- 9) Return the front end crate back to its original position, as described in the [Front End Crate Installation Procedure](#) on page 8 - 51.
- 10) Return the Vivid™ 3 rear, left and right covers, as described in the [Rear Cover Installation Procedure](#) on page 8 - 7 and the [Side Covers Installation Procedure](#) on page 8 - 4.
- 11) Raise the control console to its maximum height, and then replace the bottom keyboard cover, as described in the [Bottom Keyboard Cover Installation Procedure](#) on page 8 - 15.
- 12) Insert the air filter in its original location, as shown in [Figure 8-3](#) on page 8-5.

Note: It is recommended to clean the filter before returning it to its original location, as described in [Chapter 10 - Periodic Maintenance](#).

- 13) Verify that the gas spring release handle is functioning correctly.

8-6-8 Front Wheel Replacement Procedure

NOTE: This section describes the installation and removal procedures for the earlier-type of front wheel (Part No. 2269437) and the newer improved type (Part No. 2392789). The installation procedure is slightly different for each type of front wheel, as described in the procedures below.

When replacing the earlier type of front wheel (Part No. 2269437) with the **same** type of wheel, refer to the following instructions:

- [Front Wheel Removal - Procedure 1](#) (see below)
- [Front Wheel Installation - Procedure 1](#) on page 8 - 118.

When replacing the earlier type of front wheel (Part No. 2269437) with newer improved type (Part No. 2392789) make sure you replace **BOTH** front wheels. When ordering the new-type Front wheels, you will receive a new transverse arm which should also be replaced (between the two wheels). Refer to these instructions:

- [Front Wheel Removal - Procedure 1](#) on page 8 - 114
- [Front Wheel Installation - Procedure 2](#) on page 8 - 118.

If replacing the newer improved type (Part No. 2392789) with the **same** type of wheels, refer to the following instructions:

- [Front Wheel Removal - Procedure 2](#) on page 8 - 116
- [Front Wheel Installation - Procedure 2](#) on page 8 - 118.

8-6-8-1 Tools

Use the appropriate flat and Phillips-type screw drivers, a wire cutter, the appropriate Hex wrenches and the appropriate Allen keys as indicated in the front wheel replacement procedure.

8-6-8-2 Preparation

Shut down the Vivid™ 3 ultrasound unit, as described in [Chapter 3 - Installation](#).

8-6-8-3 Front Wheel Removal - Procedure 1

Note: Before you begin, make sure you are working on a flat surface with the wheels facing the *front* and the brake in the left (*locked*) position, preventing movement. The machine will remain stable, even after one wheel has been removed. However, for a safer working environment, it is recommended to support the unit with wooden blocks or a jack.



WARNING: Do not lean on the machine, or leave it unattended without support, if a wheel has been removed.

- 1) Remove the Vivid™ 3 front cover, as described in the [Front Cover Removal Procedure](#) on page 8 - 5.
- 2) Using a flat screwdriver, push up and release the locking spring washer located in the center of the transverse arm (wheel position bar), as shown in [Figure 8-100](#) on page 8-115. Lift the wheel position bar upwards (without completely removing it).



Figure 8-100 Releasing the Spring Washer from the Center of the Transverse Arm

- 3) Remove the four bolts (three wrench bolts and one Allen bolt) that secure the front wheel to the chassis (see [Figure 8-100](#) below) and remove the wheel.

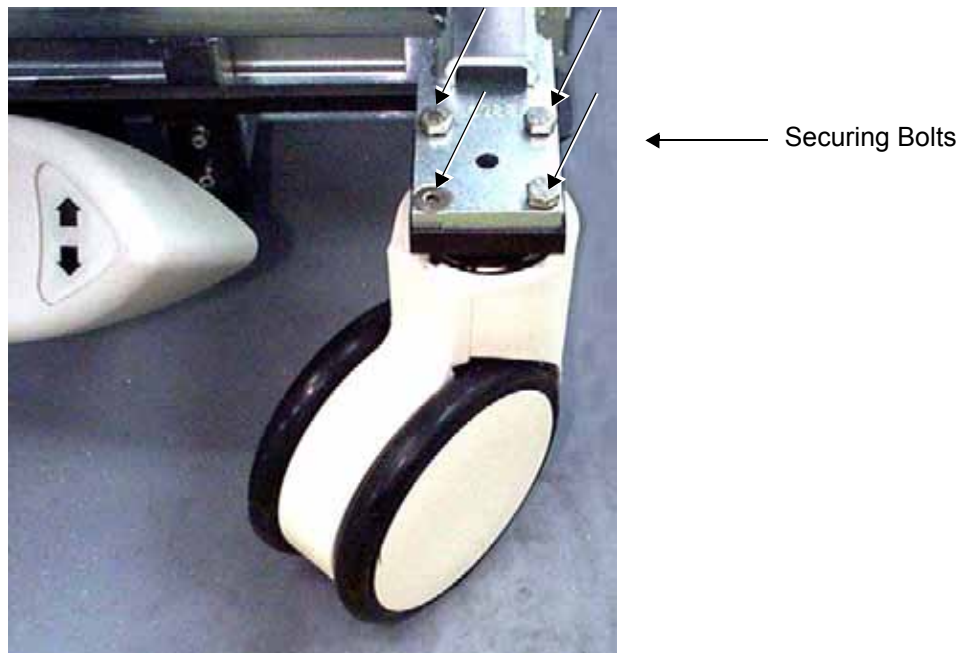

Figure 8-101 Front Wheel (Part No 2269437) Bolted to Chassis

8-6-8-4 Front Wheel Removal - Procedure 2



WARNING: When performing this procedure, the machine must be safely supported on two wooden blocks (or on a jack capable of supporting the weight of the machine). Do not lean on the machine, or leave it unattended without support, when the wheels have been removed. Always remove and replace one wheel at a time, before attempting to remove the second wheel.

Note: Before you begin, make sure you are working on a flat surface with the wheels facing the front and the brake in the left (*locked*) position, preventing movement.

- 1) Remove the Vivid™ 3 front cover, as described in the [Front Cover Removal Procedure](#) on page 8 - 5.
- 2) Remove the locking washer, located on the black wheel position bar, and lift the wheel position bar.
- 3) Using a flat screwdriver, push up and release the locking spring washer located in the center of the transverse arm (wheel position bar), as shown in [Figure 8-100](#) on page 8-115.
- 4.) Release the locking spring washer from the underside of each end of the transverse arm, as shown in [Figure 8-102](#) below.

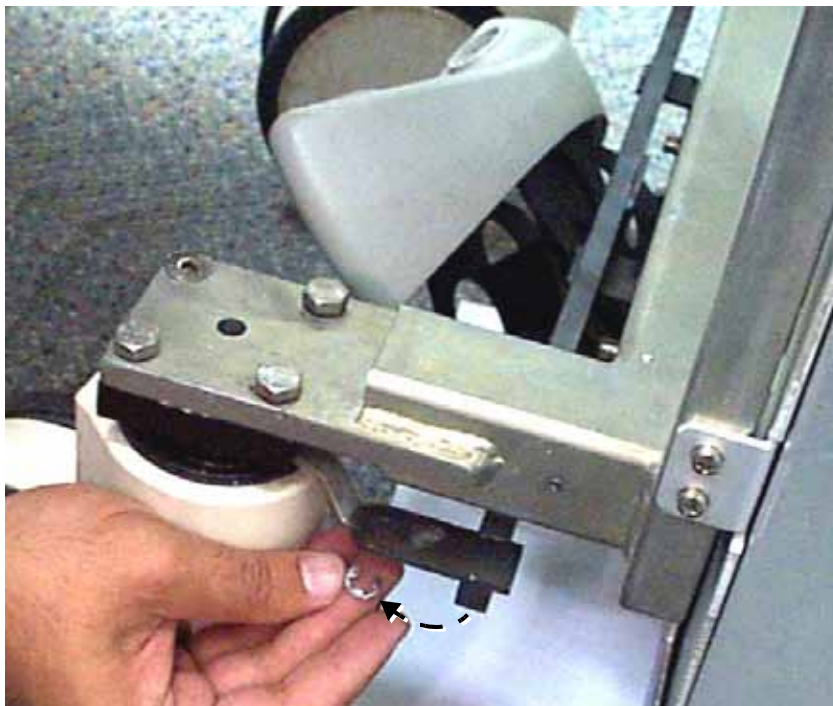

Figure 8-102 Releasing the Spring Washer from the End of the Transverse Arm

- 5.) Lifting the transverse arm upwards, unhook it from the central locking pin located above the brake pedal and remove it completely. Refer to [Figure 8-103](#) on page 8-117.



Figure 8-103 Removing the Transverse Arm

- 6) Remove the four bolts (three wrench bolts and one Allen bolt - see [Figure 8-104](#) below) that secure one of the front wheels to the chassis, and remove the wheel.

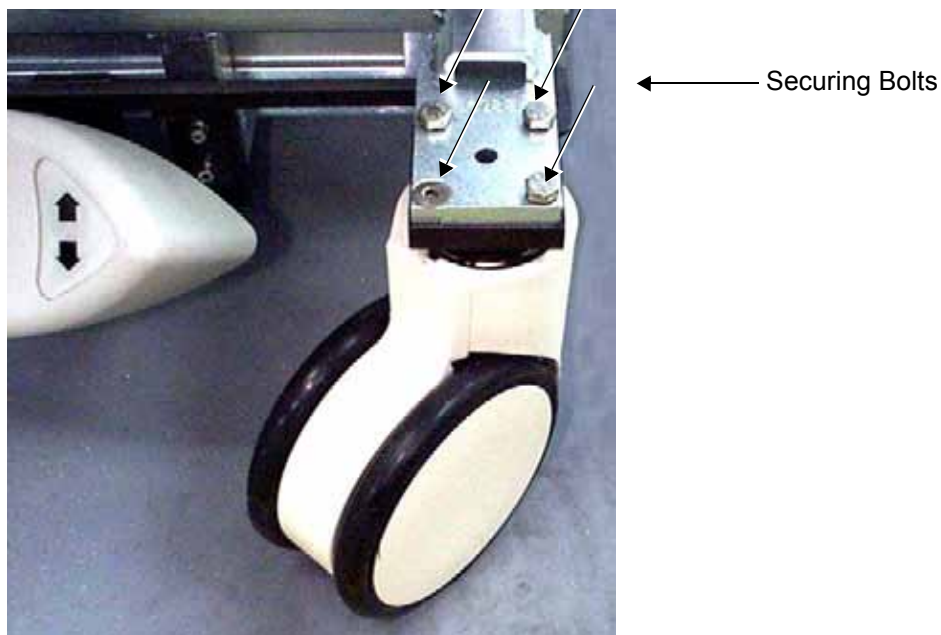

Figure 8-104 Front Wheel (Part No 2392789) Bolted to Chassis

- 7.) Proceed to [step 1](#) of the [Front Wheel Installation - Procedure 2](#) on page 8 - 118 to install a new front wheel in place of the one removed.
- 8.) Repeat [step 6](#) above, to remove the other front wheel from the chassis.
- 9.) Proceed to [step 2](#) of the [Front Wheel Installation - Procedure 2](#) on page 8 - 118, to install the second new front wheel, then complete the remaining steps of the front wheel installation procedure.

8-6-8-5 Front Wheel Installation - Procedure 1

Note: The machine will remain stable, even after one wheel has been removed. However, for a safer working environment, it is recommended to support the unit with wooden blocks or a jack.

- 1) Install the new wheel (Part No. 2269437) on the machine chassis in the same position as that of the previously-removed wheel. Make sure it is correctly positioned, parallel to the other front wheel.
- 2.) Lift the transverse arm (wheel position bar) and secure it into position by re-attaching the spring washer to the central locking pin (refer to [Figure 8-100](#) on page 8-115).
- 3.) Return the four bolts (three wrench bolts and one Allen bolt - removed in [step 3](#) on page 8-115) and make sure that wheel is secured firmly to the chassis (see [Figure 8-101](#) on page 8-115).
- 4.) Return the Vivid™ 3 front cover, as described in the [Front Cover Installation Procedure](#) on page 8 - 6.

8-6-8-6 Front Wheel Installation - Procedure 2



WARNING: When performing this procedure, the machine must be safely supported on two wooden blocks (or on a jack capable of supporting the weight of the machine). Do not lean on the machine, or leave it unattended without support, when the wheels have been removed. Always remove and replace one wheel at a time, before attempting to remove the second wheel.

- 1) Having removed one wheel from the machine chassis (as described in [Front Wheel Removal - Procedure 2](#) on page 8 - 116), install one of the new wheels (Part No. 2392789) in its place, ensuring that the wheel is correctly positioned.

Install the four bolts (three wrench bolts and one Allen bolt removed in [step 6](#) on page 8-117 [refer to [Figure 8-104](#) on page 8-117]), making sure that the wheel is secured firmly to the chassis.
- 2) Having removed the second wheel from the machine chassis (as described in [Front Wheel Removal - Procedure 2](#) on page 8 - 116), install the other new wheel in its place, ensuring that the new wheel is correctly positioned, parallel to the other new front wheel.

Install the four bolts (three wrench bolts and one Allen bolt removed in [step 6](#) on page 8-117 [refer to [Figure 8-104](#) on page 8-117]), making sure that each wheel is secured firmly to the chassis.
- 3.) Install the new transverse arm (wheel position bar) by hooking it onto the central locking pin located above the brake pedal and securing it into position (attach the spring washer [supplied] to the central pin - refer to [Figure 8-103](#) on page 8-117 and [Figure 8-100](#) on page 8-115).
- 4.) Lift the transverse arm *upwards* and attach a new locking spring washer (supplied) to the underside of each end of the transverse arm. Refer to [step 4](#) on page 8-116 and [Figure 8-102](#) on page 8-116.
- 5.) Return the Vivid™ 3 front cover, as described in the [Front Cover Installation Procedure](#) on page 8 - 6.

8-6-9 Rear Wheel Replacement Procedure

NOTE: This section describes the installation and removal procedure of the earlier-type of rear wheel (Part No. 2269436) and the newer improved type (Part No. 2389102). The installation procedure is the same for each type of rear wheel, as described in the procedure below.

NOTE: **IMPORTANT** - When replacing the earlier type (Part No. 2269436) with newer improved type (Part No. 2389102) make sure you replace **BOTH** rear wheels.

8-6-9-1 Tools

Use the appropriate flat and Phillips-type screw drivers and combination spanner as indicated in the rear wheel replacement procedure.

8-6-9-2 Preparation

Shut down the Vivid™ 3 ultrasound unit, as described in [Chapter 3 - Installation](#).

8-6-9-3 Rear Wheel Removal

Note: The machine will remain stable, even after one wheel has been removed. However, for a safer working environment, it is recommended to support the unit with wooden blocks or a jack.



WARNING: When **BOTH** rear wheels are being removed, the machine must be safely supported on two wooden blocks (or on a jack capable of supporting the weight of the machine). Always remove and replace one wheel at a time, before attempting to remove the second wheel.

- 1) Remove the Vivid™ 3 side covers and the rear cover, as described in the [Side Covers Removal Procedure](#) on page 8 - 4 and the [Rear Cover Removal Procedure](#) on page 8 - 7.
- 2) Position the machine so that the wheel that is to be changed is not in contact with the ground, while ensuring that the other three wheels remain on the ground. If replacing *both* wheels, support the machine on two wooden blocks (or a suitable jack).
- 3) Loosen the shaft screw (see [Figure 8-105](#) on page 8-120) and remove the defective wheel from the machine chassis.
- 4) Proceed to the [Rear Wheel Installation Procedure](#) on page 8 - 120 to install the new rear wheel in place of the one removed.
- 5.) If replacing *both* wheels, repeat [step 3](#) above on the other wheel, then proceed to the [Rear Wheel Installation Procedure](#) on page 8 - 120 to install the second new rear wheel and complete the rear wheel installation procedure.



WARNING: Do not lean on the machine, or leave it unattended without support, if a wheel has been removed.

8-6-9-4 Rear Wheel Installation Procedure



WARNING: Do not lean on the machine, or leave it unattended without support, if a wheel has been removed.



WARNING: When **BOTH** rear wheels are being replaced, the machine must be safely supported on two wooden blocks (or on a jack capable of supporting the weight of the machine). Always remove and replace one wheel at a time, before attempting to remove the second wheel.

- 1) Having removed one rear wheel, position the new wheel on the chassis (in the same position as that of the wheel removed).
- 2) Tighten the shaft screw (see [Figure 8-105](#) below), making sure the wheel is firmly secured.

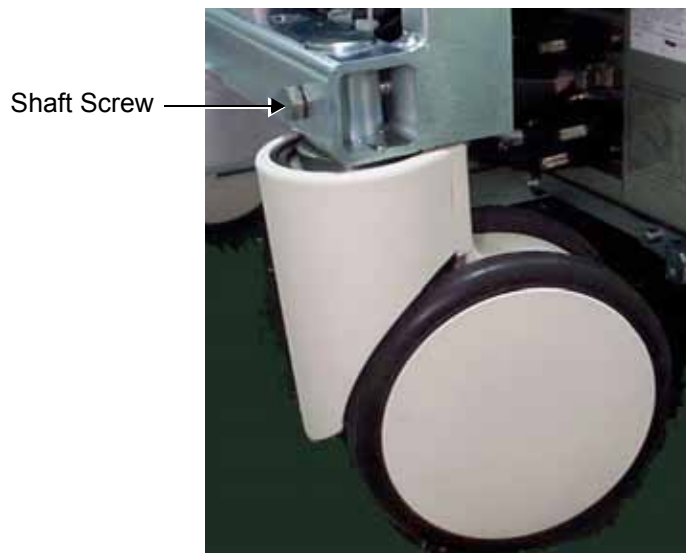

Figure 8-105 Rear Wheel Installation

- 3.) If replacing both wheels, when the second rear wheel has been removed, repeat [step 1](#) and [step 2](#) above to install the second new rear wheel.
- 4) Return the Vivid™ 3 rear, left and right covers, as described in the [Rear Cover Installation Procedure](#) on page 8 - 7 and the [Side Covers Installation Procedure](#) on page 8 - 4.

Section 8-7 Software Loading

8-7-1 Software Installation/Upgrade Procedure

Note: It is recommended to back-up the archive and the settings as described in the Vivid™ 3 Pro/ Vivid™ 3 Expert User Manual, before commencing software installation (or whenever upgrading the software).

WARNING: Do not attempt to install software that was not designated for your Vivid™ 3 unit. Attempting to install un-approved software will cause irreversible damage to hardware and software!

Normally the Vivid™ 3 system is supplied from the manufacturer with the software already installed. In some cases, it is necessary to re-install the software (for example, after replacing the Back-end Processor) by following the software installation procedure shown in [Table 8-5](#) below.

Table 8-5 Software Installation

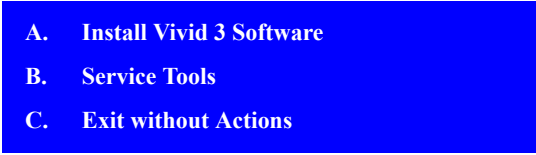
	Step	Expected Result
1	Press the <Eject> button of the CD drive and remove any media if present.	The CD drive tray ejects.
2	Insert the CD provided with the software kit, and press the <Eject> button again.	The CD drive tray will load the software CD.
3	Hold down the <ON/OFF> button for 5 seconds to shutdown the system.	The shutdown options are displayed on-screen.
4	Select Full Shutdown .	The system powers down.
5	Hold down the <ON/OFF> button for three seconds.	<p>The system powers ON and when system boot-up from the CD is complete, the following message is displayed prompting you to select the required option:</p>  <p>Select option A) Install Vivid 3 Software.</p>
6	Press <Enter>.	The CD begins the software installation process. A message is displayed on-screen prompting you to press <Eject> and remove the CD, then to press <CTRL + ALT + DELETE> to reboot the system.
7	Press <Eject> and remove the CD. Press <CTRL+ALT+DELETE>.	The system re-boots.
8	Follow the on-screen instructions, clicking OK (or Cancel) when prompted.	<p>The machine performs 4 reboots before completing the installation. The installation process will take between 20 and 50 minutes - DO NOT ATTEMPT TO STOP THE INSTALLATION BEFORE COMPLETION!</p> <p>When the installation process is complete, the system will be in regular display mode (Probe Select Screen).</p> <p>Note: If this is a new software version, an adhesive Rating Plate is supplied with the software CD. Adhere the plate in the appropriate position on the metal cover under the control console.</p>

Section 8-8 Peripherals

8-8-1 B/W Video Printer Replacement Procedure

NOTE: This section describes the installation and removal procedure for the Sony UP-895MDW B/W Video Printer.



Figure 8-106 SONY B/W Video Printer

8-8-1-1 Tools

Use the appropriate flat and Phillips-type screw drivers.

8-8-1-2 Manpower

One person - 30 mins.

8-8-1-3 Preparations

- 1) Shut down the Vivid™ 3 ultrasound unit, as described in [Chapter 3 - Installation](#).
- 2) Remove the Connectors Panel cover as shown in the [Connector Panels Cover Removal Procedure](#) on page 8 - 8.
- 3) Unpack the B/W Video Printer.
- 4) Check that the B/W Video Printer AC voltage corresponds to that of your local voltage.
- 5) Verify that all the DIP Switches on the rear panel of the B/W Video Printer are in the **Down** position as shown in [Figure 8-107](#) on page 8-124.

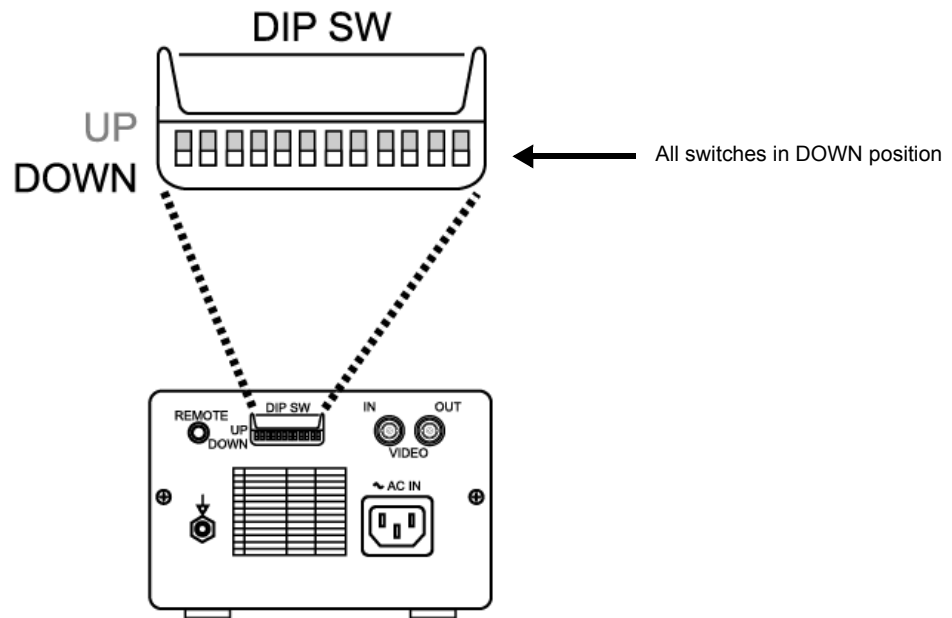
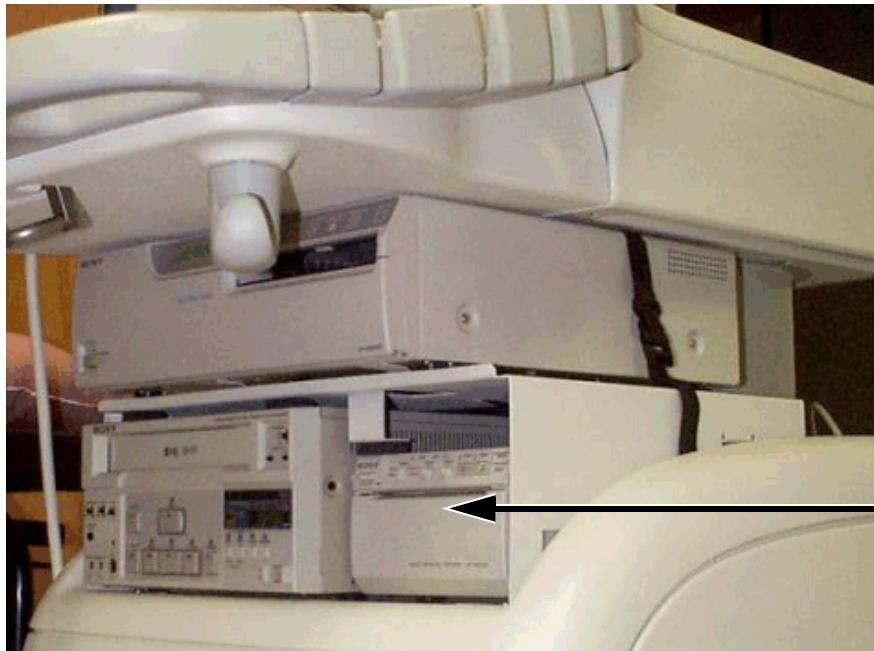

Figure 8-107 B/W Video Printer, DIP Switches on the Rear Panel

8-8-1-4 B&W Printer Installation Procedure

- 1.) Place the B/W Video Printer on the *right* side of the Vivid™ 3 ultrasound unit's top surface (below the control console - as shown in Figure 8-108) and next to the VCR (if present), allowing sufficient room to access the cables at the rear of the printer.



B/W Video Printer

**Figure 8-108 B/W Video Printer Installed in the Vivid™ 3
(Configuration for UP2950 and 2800 Printers)**



B/W Video Printer

**Figure 8-109 B/W Video Printer Installed in the Vivid™ 3
(Configuration with UP21MD Printer)**

- 2.) Connect the Remote cable, the B/W Video IN cable, and the Power cable, as shown in [Figure 8-110](#) below.

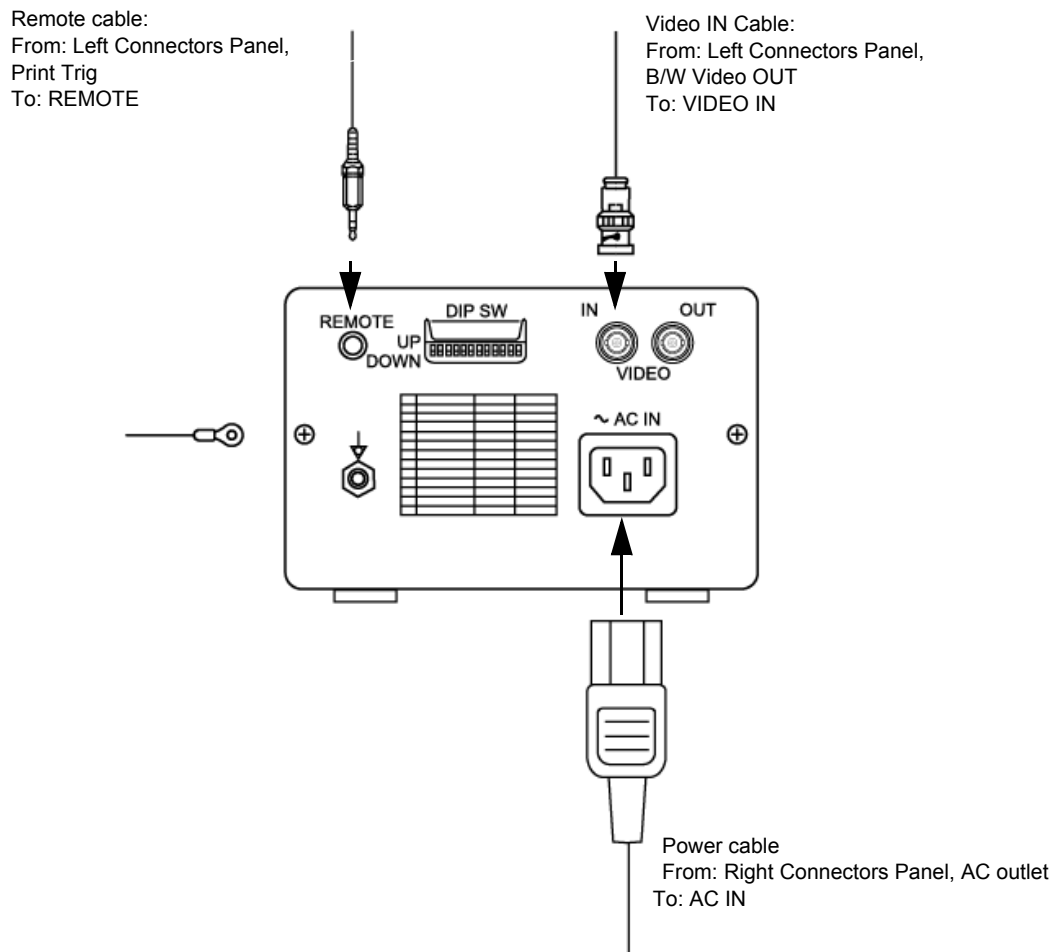

Figure 8-110 B/W Video Printer Connection Cables

- 3.) Place the B/W printer in its correct final position.
- 4.) Secure the B/W printer by fastening the belt around it, or together with the VCR (if present).
- 5.) If more secure fastening is desired, install the optional shelf (P/N H45011CN), which can be ordered separately if the Color Printer option is not installed.

NOTE: For shelf installation instructions refer to *Color Printer installation in the [Color Video Printer Installation - Procedure 1](#)* section, page 8-157.

- 6.) Re-install the Connectors Panels Cover as described in the [Connector Panels Cover Installation Procedure](#) on page 8 - 8.
- 7.) Reconnect the mains AC power cable from the wall outlet.
- 8.) Turn ON the main circuit breaker located on rear of the Vivid™ 3.
- 9.) Turn ON the Vivid™ 3 by pressing the ON/OFF button on the Control Console.
- 10.) Select the activation key under System Configuration, VCR/ECG Tab, A/B Swap. By default, Print B key will be B&W Video printer and Print A key will be Color Video printer. For more information on switching printer settings, see [VCR/ECG Tab](#) on page 3 - 45.

8-8-1-4-1 Setting the Switches on the Paper Tray

- 1.) Press the OPEN button in the front of the B/W Video Printer.
- 2.) Ensure that the switches on the Paper Tray are set as shown in [Figure 8-111](#) below.
- 3.) Load the Paper Roll as described in the Printer's Operating Instructions.

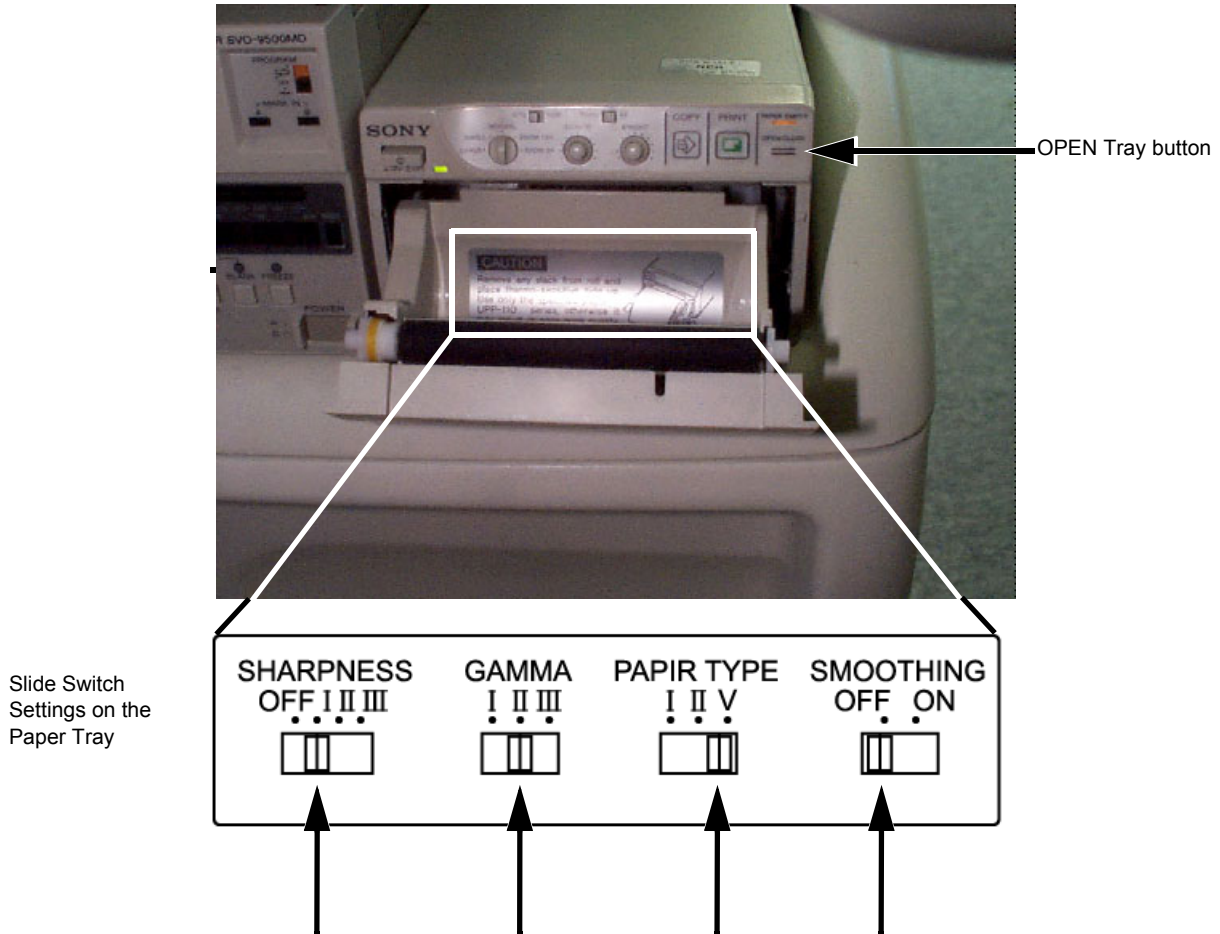

Figure 8-111 B/W Video Printer, Slide Switches Location and Settings on the Paper Tray

8-8-1-5 B&W Printer Removal Procedure

- 1.) Remove the Connectors Panels Cover as described in the [Connector Panels Cover Removal Procedure](#) on page 8 - 8.
- 2.) If optional shelf (P/N H45011CN) is present, refer to [Color Video Printer Removal - Procedure 1](#) section, page 8-161.
- 3.) Release the B/W printer by undoing the fastening belt secured around it (and around the VCR, if present).
- 4.) Disconnect the Remote cable, the B/W Video IN cable, and Power cable from rear of the printer (refer to [Figure 8-110](#) on page 8-126).
- 5.) Remove the B/W Video Printer from the *right* side of the Vivid™ 3 ultrasound unit (taking it out from below the control console and from beside the B/W printer, if present) - refer to [Figure 8-108](#) on page 8-125.

8-8-2 Mitsubishi VCR Replacement Procedure

NOTE: This section describes the installation and removal procedure of the following MITSUBISHI VCR models:

- HS-MD3000E (PAL) - P/N: 066E9513
- HS-MD3000U (NTSC) - P/N: 066E9514

The VCR will not operate without initial setup and adjustments, as described below.



Figure 8-112 Mitsubishi Video Cassette Recorder (VCR)

8-8-2-1 Tools

No special tools needed.

8-8-2-2 Manpower

One person - 30 mins.

8-8-2-3 Preparations

- 1) Shut down the Vivid™ 3 ultrasound unit, as described in [Chapter 3 - Installation](#).
- 2.) Remove the Connectors Panels Cover as described in the [Connector Panels Cover Removal Procedure](#) on page 8 - 8.
- 3.) Unpack the VCR.
- 4.) Check that the VCR AC voltage corresponds to that of your local voltage.

8-8-2-4 Mitsubishi VCR Installation Procedure

- 1.) Place the VCR on the *left* side of the Vivid™ 3 ultrasound unit's top surface (below the control console - as shown in [Figure 8-113](#) below) and next to the B/W Printer, if present, allowing sufficient room to access the cables at the rear of the VCR.



Figure 8-113 Video Cassette Recorder (VCR) Installed in the Vivid™ 3 Ultrasound Unit Configuration with UP2950 Printer

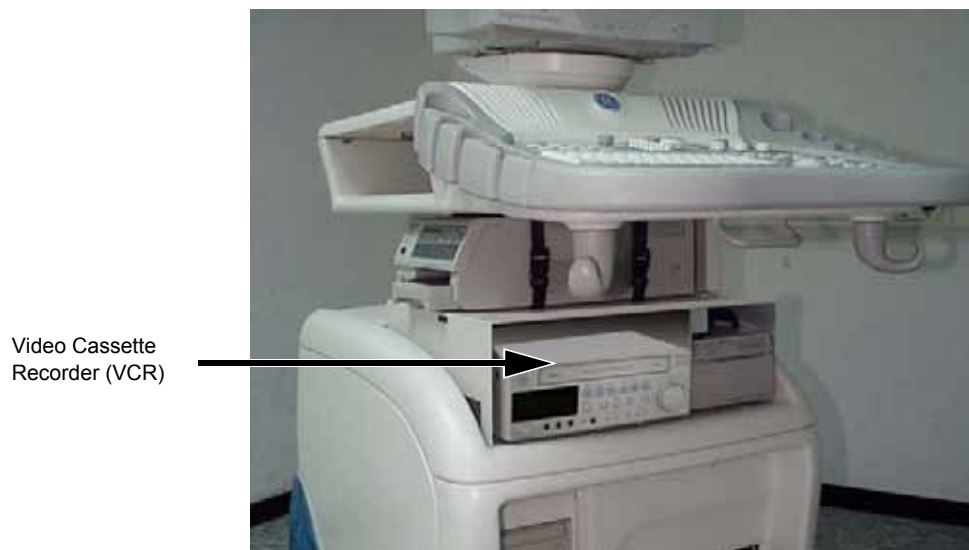

Figure 8-114 Video Cassette Recorder (VCR) Installed in the Vivid™ 3 Ultrasound Unit (Configuration with UP21MD Color Printer and Shelf)

- 2.) Connect one end of the VCR power cable (P/N: 2269430) to the power outlet on the Vivid 3 rear panel and the other end to the AC power socket on the VCR rear panel - see [Figure 8-115](#) on page 8-130.
- 3.) Using the S-video cable (P/N: 2266743), connect one end to the **Video OUT** socket on the VCR rear panel (refer to [Figure 8-115](#)) and the other to the **Video IN** socket on the Vivid 3 rear panel.



Figure 8-115 Mitsubishi VCR Rear Panel

- 4.) Boot up the Vivid™ 3 ultrasound unit by pressing the ON/OFF button on the control console.
- 5.) Power ON the VCR by pushing the power switch on VCR front panel.



Figure 8-116 Mitsubishi VCR Front Panel - Power Switch

- 6.) Press **Config** then, from the System Configuration window, activate the **VCR / ECG** tab.

7.) Under the VCR Options list, choose Mitsubishi from the **VCR model** drop-down list (Figure 8-117).

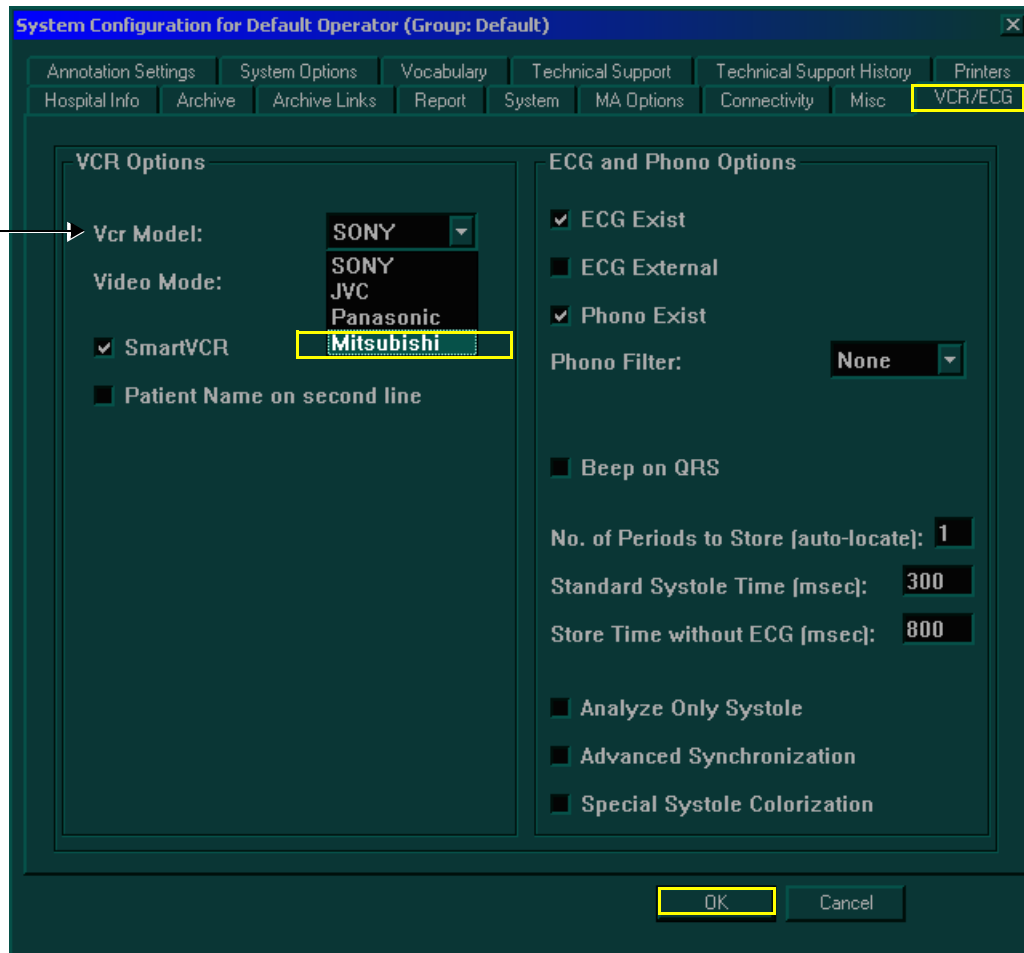

Figure 8-117 Selecting VCR Model - Mitsubishi

- 8.) From the **Video Mode** drop-down list, choose PAL or NTSC (according to video system in your region), then press **OK** to apply the changes.
- 9.) Proceed to the VCR Setup procedure, described below.

8-8-2-4-1 Mitsubishi VCR Setup Procedure

NOTE: This procedure must be performed on initial Mitsubishi VCR installation.

NOTE: The Mitsubishi VCR can be configured using the Menus on the front panel (Figure 8-118) as follows:

- Use the **Jog button** to navigate between the selections.
- Push the **Enter button** to apply your selection.

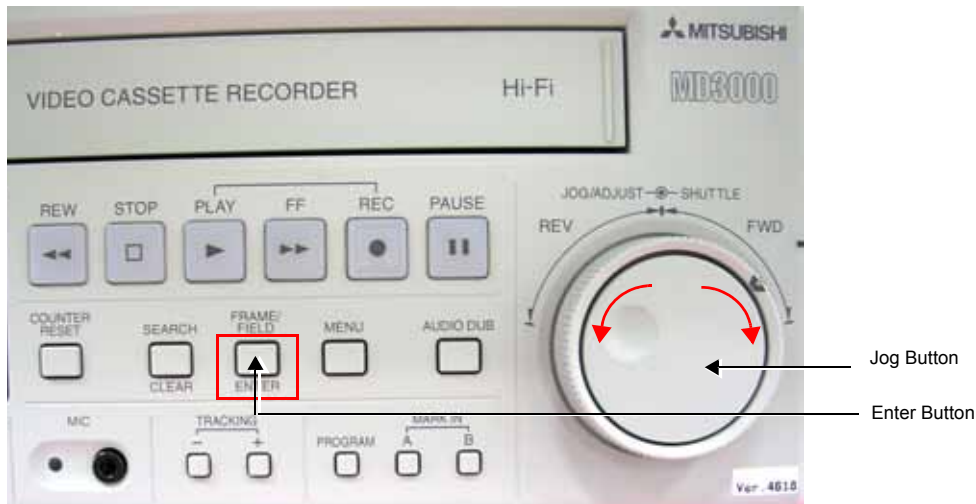

Figure 8-118 Mitsubishi VCR Front Panel

To configure the Mitsubishi VCR:

- 1.) Press the **VCR Play B.** button on the Vivid™ 3 control console to display the VCR menus on the Vivid™ 3 monitor.
- 2.) Using the *Jog* button on the VCR front panel (Figure 8-118), select the required VCR menu language (Figure 8-119), then press the *Enter* button to continue to the next menu.



Figure 8-119 Language Menu

- 3.) Select the **<Menu1>** settings, according to the configuration shown in Figure 8-120 below, then press the *Enter* button to continue to the next menu.



Figure 8-120 Menu 1 Settings

- 4.) Select the **<Menu2>** settings, according to the configuration shown in [Figure 8-121](#) below , then press the *Enter* button to continue to the next menu.



Figure 8-121 Menu 2 Settings

- 5.) Skip **<Menu3>** ([Figure 8-122](#)) by pressing the *Enter* button to continue to the next menu.



Figure 8-122 Menu 3

- 6.) Select the **<RS-232C>** settings, according to the configuration shown in [Figure 8-123](#) below, then press the *Enter* button to continue to the next menu.



Figure 8-123 RS-232C Menu Settings

- 7.) Skip the <Elapsed Time> (Figure 8-124) by pressing the *Enter* button.



Figure 8-124 Elapsed Time Menu

- 8.) Connect the RS-232C cable and the Audio IN and Audio OUT cables between the appropriate connections on the Vivid 3 rear panel and the Mitsubishi VCR rear panel (refer to Figure 8-115 on page 8-130).
- 9.) On the VCR front panel, verify that the *Monitor* and *Audio* switches are in the positions shown in Figure 8-125 below (if necessary, adjust accordingly) - then move the Key Lock switch to the **ALL** position to lock all keys.

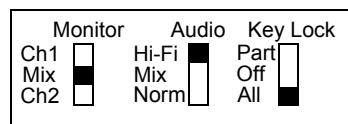

Monitor	Mix	Determines what is sent to MONITOR OUT jack. (Has no effect on AUDIO OUT).
Audio	Hi-Fi	Output High Fidelity audio to AUDIO OUT CH-1/L and CH-2/R
Key Lock	ALL	All keys locked in position.



Figure 8-125 Mitsubishi VCR - Switches Settings (Front Panel)

- 10.) Perform the VCR Test, as described in the [VCR Test](#) on page 4 - 4.

8-8-2-5 Mitsubishi VCR Removal Procedure

- 1.) Remove the Connectors Panels Cover as described in the [Connector Panels Cover Removal Procedure](#) on page 8 - 8.
- 2.) If optional shelf (P/N H45011CN) is present, refer to the [Color Video Printer Removal - Procedure 1](#) on page 8 - 161.
- 3.) Disconnect the RS-232C cable, the Audio and S-Video IN and OUT cables, and Power cord from VCR's rear as shown in [Figure 8-115](#) on page 8-130.
- 4.) Remove the VCR from the *left* side of the Vivid™ 3 ultrasound unit (taking it out from below the control console and from beside the B/W printer, if present) - refer to [Figure 8-113](#) on page 8-129.

8-8-3 Sony VCR Replacement Procedure

NOTE: This section describes the installation and removal procedure of the SONY SVO-9500MDP2 and SVO-9500MD2.

The SVO-9500MDP2 (PAL) and SVO-9500MD2 (NTSC) are alike, except for the Color Signal system. The installation procedure is the same for both models.



Figure 8-126 SONY Video Cassette Recorder (VCR)

8-8-3-1 Tools

No special tools needed.

8-8-3-2 Manpower

One person - 30 mins.

8-8-3-3 Preparations

- 1) Shut down the Vivid™ 3 ultrasound unit, as described in [Chapter 3 - Installation](#).
- 2.) Remove the Connectors Panels Cover as described in the [Connector Panels Cover Removal Procedure](#) on page 8 - 8.
- 3.) Unpack the VCR.
- 4.) Check that the VCR AC voltage corresponds to that of your local voltage.
- 5.) Verify that the switches on the VCR front panel are as shown in [Figure 8-127](#) below. If necessary, adjust accordingly.

Monitor	Audio	Hi-Fi
Ch1 <input type="checkbox"/>	Hi-Fi <input checked="" type="checkbox"/>	On <input checked="" type="checkbox"/>
Mix <input checked="" type="checkbox"/>	Mix <input type="checkbox"/>	Off <input type="checkbox"/>
Ch2 <input type="checkbox"/>	Norm <input type="checkbox"/>	

Monitor	Mix	Not important. (Determines what is sent to MONITOR OUT jack. Has no effect on AUDIO OUT).
Audio	Hi-Fi	Output High Fidelity audio to AUDIO OUT CH-1/L and CH-2/R
Hi-Fi	ON	Record High Fidelity audio, if present

Figure 8-127 Sony VCR - Switches Setting (Front Panel)

- 6.) Verify that the switches on the VCR rear panel are as shown in Figure 8-128 below. If necessary, adjust accordingly.

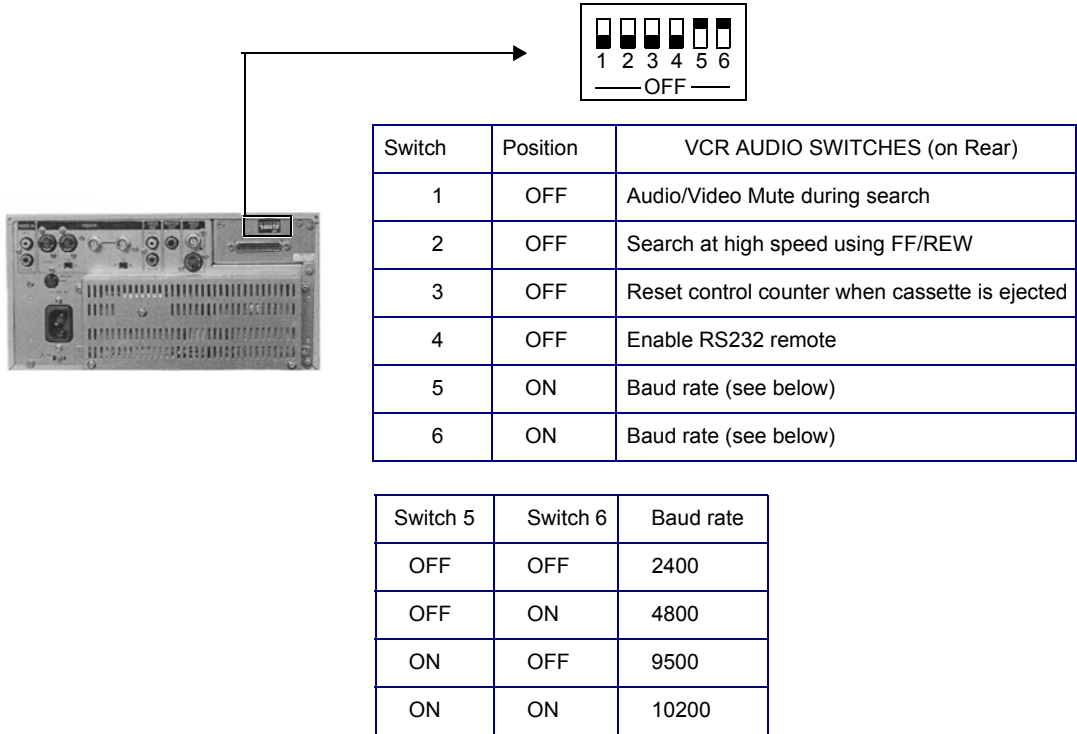

Figure 8-128 Sony VCR - Switches Setting (Rear Panel)

8-8-3-4 Sony VCR Installation Procedure

- 1.) Place the VCR on the *left* side of the Vivid™ 3 ultrasound unit's top surface (below the control console - as shown in [Figure 8-129](#) below) and next to the B/W Printer, if present, allowing sufficient room to access the cables at the rear of the VCR.

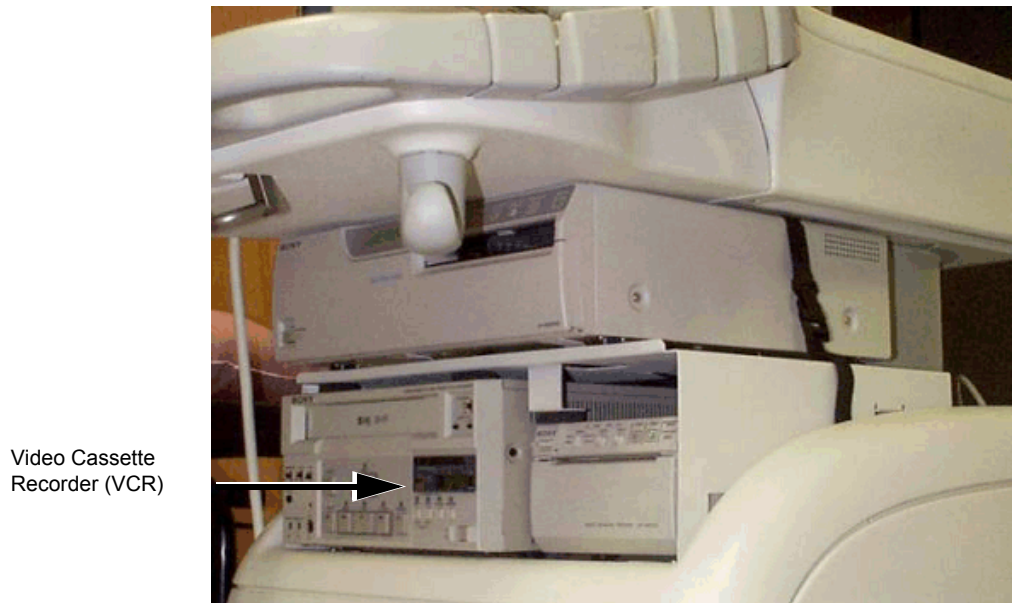

Figure 8-129 Video Cassette Recorder (VCR) Installed in the Vivid™ 3 Ultrasound Unit Configuration with UP2950 Printer

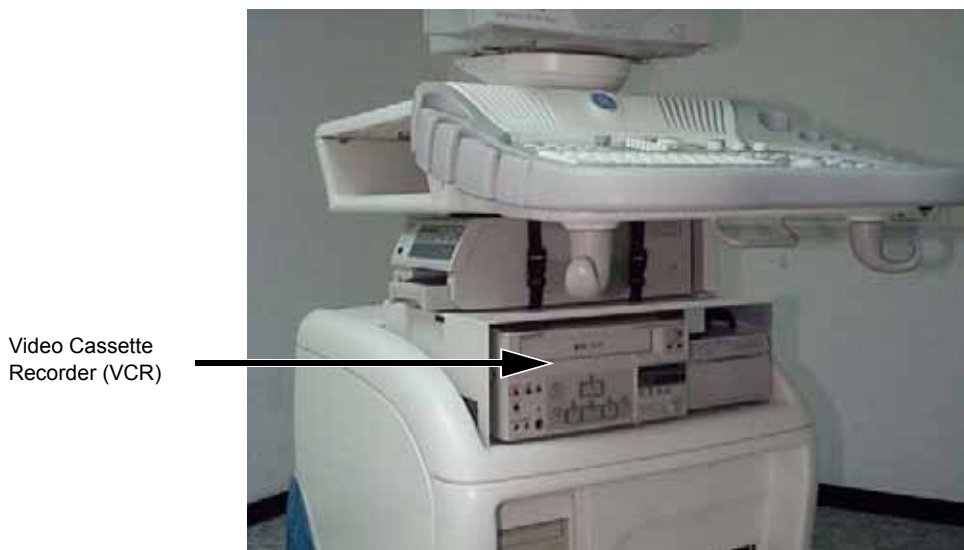

Figure 8-130 Video Cassette Recorder (VCR) Installed in the Vivid™ 3 Ultrasound Unit (Configuration with UP21MD Color Printer and Shelf)

- 2.) Connect the RS-232C cable, the Audio and S-Video IN and OUT cables, and the Power cord, as shown in Figure 8-131.

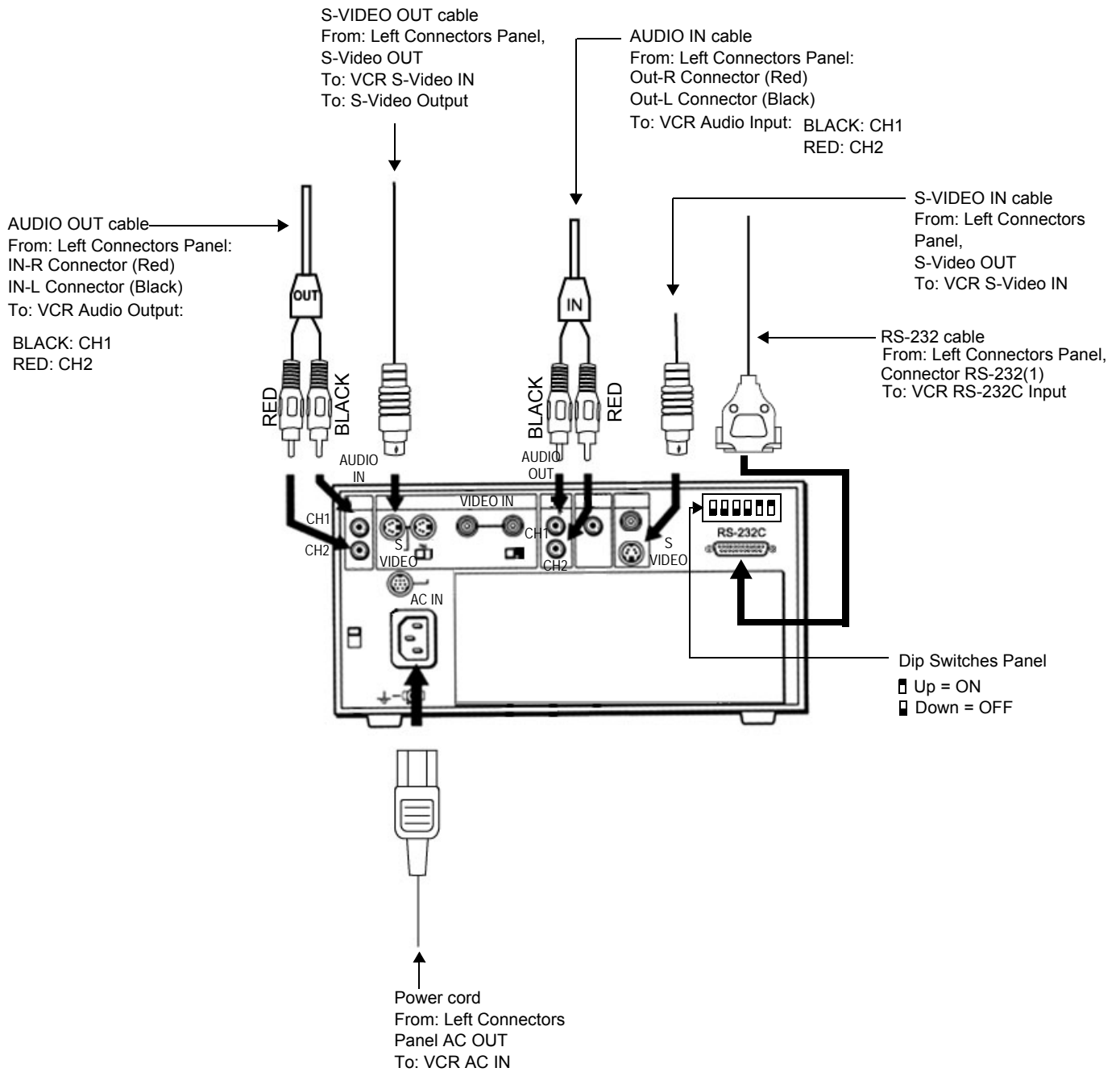

Figure 8-131 Sony VCR Connection Cables

- 3.) Place the VCR in its correct final position.
- 4.) Secure the VCR by fastening the belt around it, or together with the B/W Printer (if present).
- 5.) If more secure fastening is desired, install the optional shelf (P/N H45011CN), which can be ordered separately if the Color Printer option is not installed.

NOTE: For shelf installation instructions refer to the [Color Video Printer Installation - Procedure 1](#) on page 8 - 157.

- 6.) Re-install the Connectors Panels Cover as described in the [Connector Panels Cover Installation Procedure](#) on page 8 - 8.
- 7.) Reconnect the mains AC power cable from the wall outlet.
- 8.) Turn ON the main circuit breaker located on rear of the Vivid™ 3.
- 9.) Turn ON the Vivid™ 3 by pressing the ON/OFF button on the Control Console.
- 10.) Under System Configuration, VCR/ECG Tab, select the appropriate VCR mode options. For more information, see [VCR/ECG Tab](#) on page 3 - 45.

Note: Sony VCR - Reset Counter:

If the Reset Counter button is activated while the VCR is in the *Stop*, *Pause*, or *Record* state, the counter display is reset to *zero* (0:00:00).

8-8-3-5 Sony VCR Removal Procedure

- 1.) Remove the Connectors Panels Cover as described in the [Connector Panels Cover Removal Procedure](#) on page 8 - 8.
- 2.) If optional shelf (P/N H45011CN) is present, refer to the [Color Video Printer Removal - Procedure 1](#) on page 8 - 161.
- 3.) Release the B/W printer by undoing the fastening belt around it (together with the VCR, if present).
- 4.) Disconnect the RS-232C cable, the Audio and S-Video IN and OUT cables, and Power cord from VCR's rear as shown in [Figure 8-131](#) on page 8-139.
- 5.) Remove the VCR from the *left* side of the Vivid™ 3 ultrasound unit (taking it out from below the control console and from beside the B/W printer, if present) - refer to [Figure 8-129](#) on page 8-138.

8-8-4 JVC VCR Replacement Procedure

NOTE: This section describes the installation and removal procedure of the JVC Video Cassette Recorder.

The SR-S388E (PAL) and SR-S365U (NTSC) models are alike, except for the Color Signal system.

The installation procedure is the same for both models.

Note: When installing the JVC VCR, use the cables supplied with the VCR and **not** those supplied with the **Vivid 3** system.



Figure 8-132 JVC Video Cassette Recorder (VCR)

8-8-4-1 Tools

No special tools needed.

8-8-4-2 Manpower

One person - 30 mins.

8-8-4-3 Preparations

- 1.) Shut down the Vivid™ 3 ultrasound unit, as described in [Chapter 3 - Installation](#).
- 2.) Remove the Connectors Panel cover as shown in the [Connector Panels Cover Removal Procedure](#) on page 8 - 8.
- 3.) Unpack the VCR and place it on a table (or firm surface).
- 4.) Check that the VCR AC voltage corresponds to that of your local voltage.
- 5.) Proceed to the [JVC VCR Setup Procedures](#) on the next page.

8-8-4-4 JVC VCR Setup Procedures

8-8-4-4-1 Front Panel Setup



Figure 8-133 JVC VCR Front Panel - Switch Settings

- 1) Open the flip-down switch cover on the lower *left* side of the JVC front panel (by pulling *downwards*), as seen in [Figure 8-133](#), above.
- 2.) Check that the switch settings for each of the following switches is correct (as shown below). If necessary, adjust accordingly:

TBC - Set to **OFF**

Hi Fi Select - Set to **Hi-Fi L + R**
If setting incorrect, press the Hi Fi Select button repeatedly until Hi-Fi L + R is selected (and visible at the bottom of the LCD display).

Y/C Line (video input) - Set to **Y/C**

RS-232C/Local/Remote - Set to **RS-232C**

8-8-4-4-2 BIOS Setup

NOTE: If you have an external monitor, you can connect it to the Monitor Out - Video socket on the VCR rear panel (see [Figure 8-134](#) below), which will enable you to view the different menus as they are being edited for the BIOS setup. **For best image quality during recording and playback, this is the recommended setup procedure.**



Figure 8-134 JVC VCR - Rear Panel - External Monitor Connection

- 1.) Connect the AC power cable to the AC Input socket on the VCR rear panel (upper *left* corner) and plug the other end of the cable into the mains power wall outlet.
- 2.) Turn ON power to the VCR.
- 3.) If an external monitor is connected to the VCR, make sure power to the monitor is also ON.
- 4.) Press the **Menu** button on the JVC Front Panel - see [Figure 8-135](#) below.



Figure 8-135 JVC VCR Front Panel Controls

The LCD Display panel (refer to [Figure 8-133](#) on page 8-142) becomes illuminated.

NOTE: If an external monitor is connected (see Note above), the Menu Switch Setting Screen is displayed (on the external monitor). While making changes to the Menu Switch settings, these may be monitored in this display.
If an external monitor is not connected, the Menu # and currently-selected value is only visible in the LCD Display on the JVC VCR front panel.

- 5.) Use the **Select** button (see [Figure 8-135](#)) to select *MEMORY SW* and then press the **Set** button.
- 6.) Using the **Select** and **Set** buttons, scroll through the various Menus and set the values for each of the relevant Menus, in accordance with those shown in [Table 8-6](#) below.

NOTE: Work in the same order as that given in [Table 8-6](#) and do not change any settings other than those listed.

Table 8-6 JVC VCR Menu Switch Settings

Menu No.	Name	Set Value
100	S-VHS SELECT	[AUTO] (1)
101	EDIT SELECT	ENHANCED (2)
200	Hi-Fi AUDIO REC.	[ON] (1)
213	A.DUB SELECT	[A.DUB] (0)
335	RECORDING MODE	[SP] (0)
338	MENU SW 2	OPEN (1)
352	COUNTER MODE	CTL (1)
500	ON SCREEN DISPLAY	OFF (0)
005	AUTO TRACKING	[ON] (1)
204	Hi-Fi OUT AT SEARCH	[MUTE] (0)
212	NORM OUT AT SEARCH	OFF (0)
300	DIRECT EJECT	[ENABLE] (1)
312	MODE AT TAPE END	STOP (0)
354	BAUDRATE SELECT	[9600] (3)
359	16: 9 REC	OFF (0)
504	INFORMATION SELECT	TIME (0)

NOTE: In [Table 8-6](#), square brackets [] indicate factory presets. The numbers in parenthesis () are seen on the LCD display.

- 7.) When all the above-mentioned settings are correct, press the **Menu** button, select *CLOCK ADJUST* and press the **Set** button. Using the **Select** and **Set** buttons, adjust the settings to the correct time. When the correct time is visible in the LCD display, press the **Menu** button, to quit *CLOCK ADJUST*.
- 8.) Turn OFF power to the VCR. Remove the AC power cable from the mains power wall outlet and disconnect the cable from the VCR rear panel.

If an external monitor was used for the BIOS setup procedure, turn OFF power to the external monitor and disconnect the power cable (connected to the VCR rear panel Monitor Out - Video socket - refer to [Figure 8-134](#) on page 8-143).

NOTE: All settings are now stored in the VCR memory and the JVC VCR is ready for installation.

8-8-4-5 JVC VCR Installation Procedure

- 1.) Remove the white metal shelf from inside the side compartment (located on the *left* side of the control console) as described on [page 8-17](#).
- 2.) Discard the shelf.
- 3.) Raise the control console to its *maximum* height and remove the console bottom cover (upper section) as described on [Control Console Bottom Cover \(Upper Section\) Removal Procedure](#) on page 8-17.
- 4.) Connect the VCR cables (listed below) to the appropriate sockets on the VCR rear panel (as shown in [Figure 8-136](#)):
 - Audio Input
 - Audio Output
 - Video Input (YC IN)
 - Video Output (YC OUT)
 - RS-232C

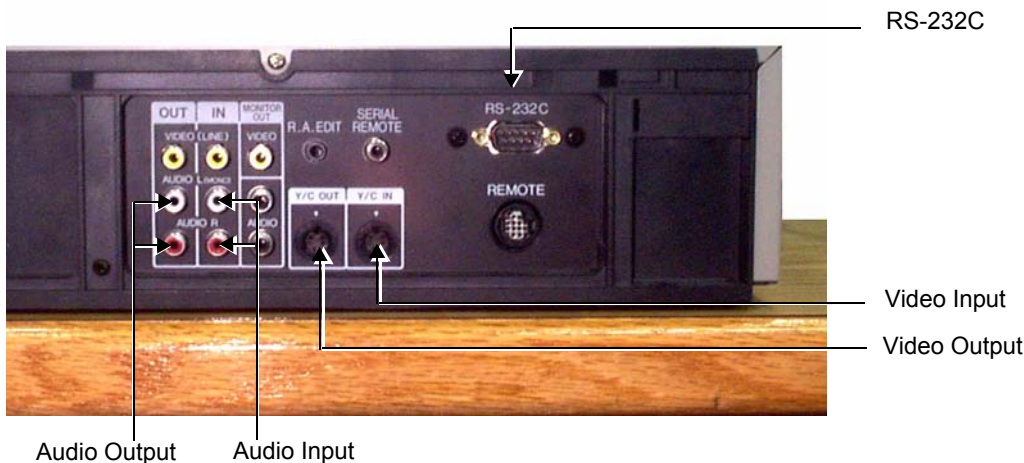

Figure 8-136 JVC VCR - Rear Connectors Panel

- 5.) Connect one end of the cable extender supplied with the VCR (see [Figure 8-137](#) below) to the AC power cable (already attached to the VCR).

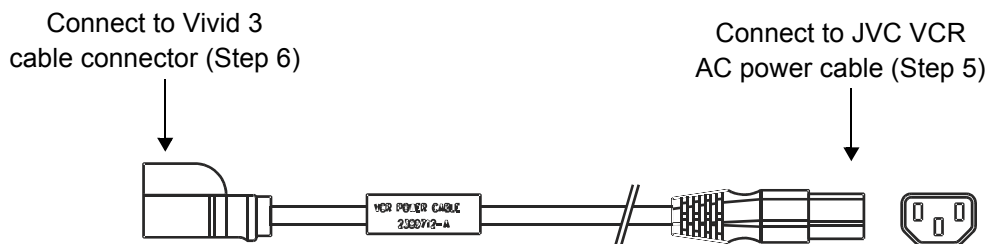

Figure 8-137 JVC VCR Cable Extender

NOTE: When connecting the VCR AC Power cable, always use the cable extender supplied with the VCR.

- 6.) Connect the other end of the cable extender to the cable connector on the Vivid™ 3, as shown in [Figure 8-138](#) below (refer also to [Figure 8-137](#), above).

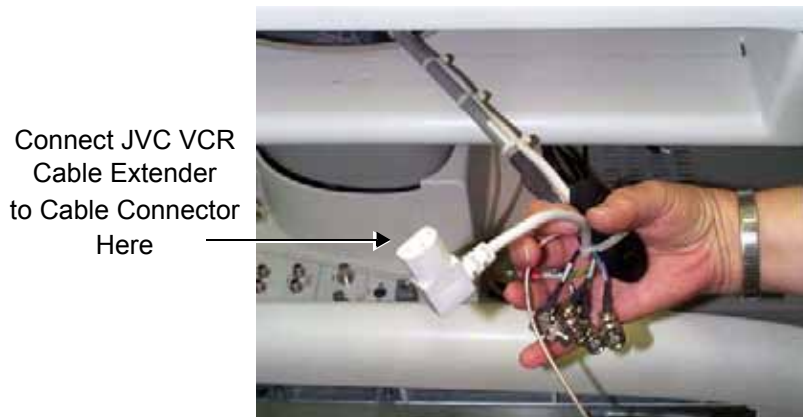

Figure 8-138 Cable Connector on Vivid™ 3

- 7.) Carefully slide the VCR into the side compartment, and at the same time, route all the cables through the gap between the compartment base and the *right* side of the compartment (as shown in [Figure 8-139](#) below) while gently pulling them in a *downwards* direction.

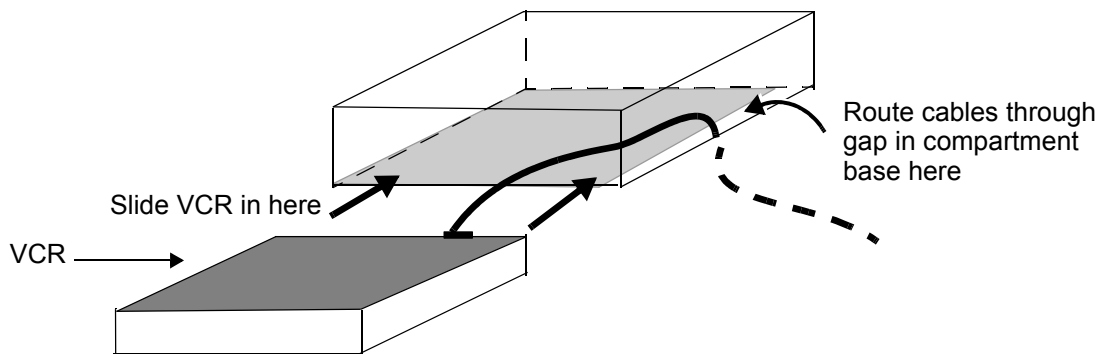

Figure 8-139 Sliding JVC VCR into Side Compartment

- 8.) Continue sliding the VCR all the way back into the final position with one hand, while gently pulling the cables in a *downwards* direction. The VCR and attached cables are now positioned as shown in [Figure 8-140](#) below.

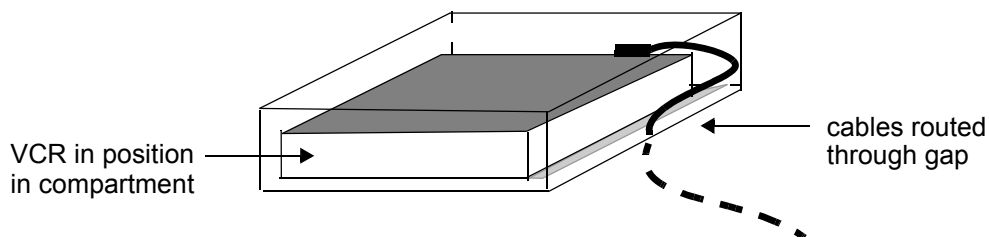

Figure 8-140 JVC VCR in Position in Side Compartment

- 9.) Check that the VCR fits properly in position and does not extend beyond the edge of the side compartment - see [Figure 8-141](#) below.



Figure 8-141 JVC VCR Installed in Compartment

NOTE: *In order to eliminate the risk of the JVC VCR moving or falling out of the compartment whenever the **Vivid 3** ultrasound unit is moved, a removable L-shaped aluminium stopper (Part No. 2401662) is fitted to the floor of the side compartment, as described below. This serves to secure the VCR firmly in position.*

- 10.) Make sure the surface of the side compartment is thoroughly clean and dry.
11.) Check that the outer sides of the L-shaped aluminium VCR stopper strip are clean and dry.
12.) Cut two pieces of self-adhesive velcro strip (supplied with the VCR), each approximately 8 cm (3 in) in length.
13.) Holding one of the velcro strips, remove the protective sheet from the self-adhesive side (*hook* section) and carefully apply the strip to the outer side of the aluminium VCR stopper, placing it close to the edge as shown in [Figure 8-142](#) below. Press down to secure firmly in position.

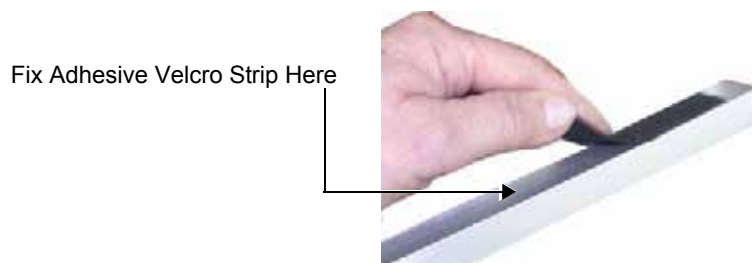

Figure 8-142 Applying Velcro Strip to Outer Side of Aluminium Stopper

- 14.) Repeat [step 13](#) to apply the second velcro strip to the other end of the aluminium VCR stopper, placing it close to the edge (with the two strips evenly spaced apart).

- 15.) Separate the upper (loop) section from each of the velcro strips and repeat [step 13](#) to apply each section to the floor of the side compartment, parallel to the lower edge of the VCR as shown in [Figure 8-143](#) below. Press down firmly to ensure the two sections are securely attached.



Fix Adhesive Velcro Strips Here

Figure 8-143 Velcro Strips Fastened to Floor of Side Compartment

- 16.) Holding the aluminium VCR stopper with the velcro hook side facing *downwards*, fix it in position in front of the VCR, taking care to properly align the velcro strips. Press down firmly to ensure the stopper is securely fastened - refer to [Figure 8-144](#) below.



Aluminium Stopper in Position

Figure 8-144 Aluminium Stopper In Front of VCR

- 17.) Bundle all the VCR cables together into a single loom and bind together with cable ties.
18.) With the control console still at the *maximum* height, route the cable loom down to the **left** rear connectors panel (at the rear of the **Vivid 3** unit).
19.) Fasten the loom to the Vivid™ 3 bottom cover using the square adhesive cable fastener (supplied).

20.) Connect the RS-232C cable, the Audio and S-Video IN and OUT cables, and the Power cable to the appropriate sockets on the Vivid™ 3 rear connectors panel - see [Figure 8-145](#).

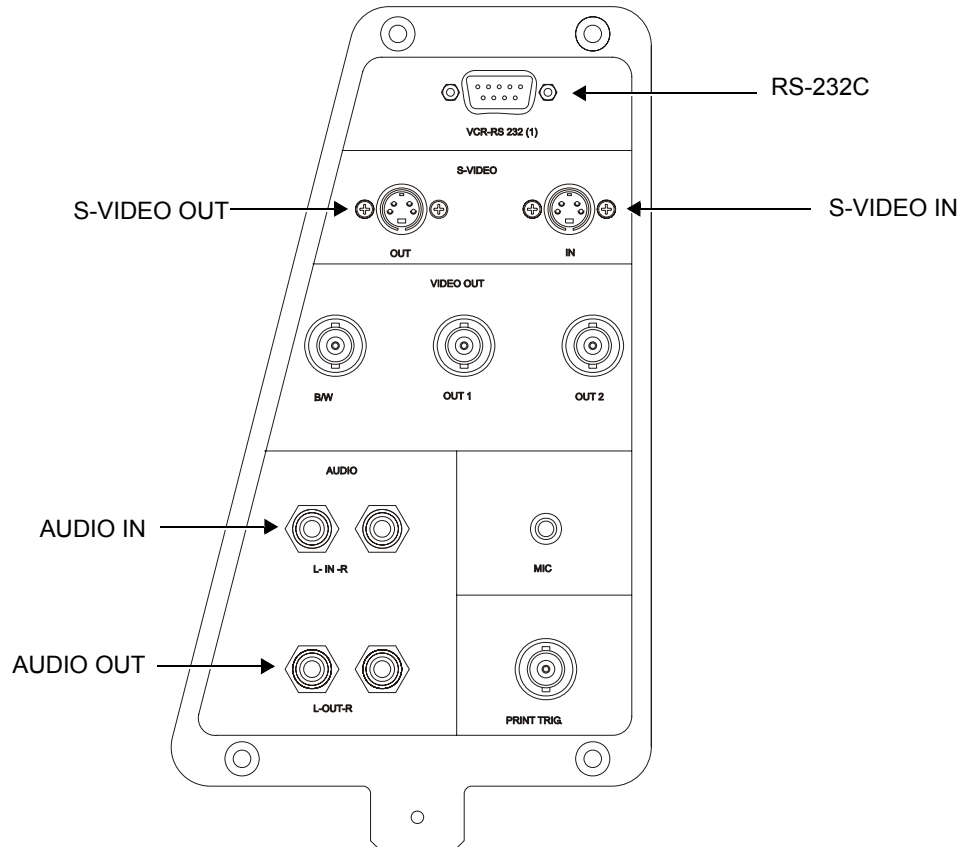

Figure 8-145 Vivid™ 3 Left Rear Panel Connectors

21.) Return the console bottom metal cover (upper section) (removed in [step 3](#)). Make sure the VCR cable loom is properly aligned to pass through the slot in the cover (as shown in [Figure 8-146](#) below) and that there is no kinking or pinching of the cables.

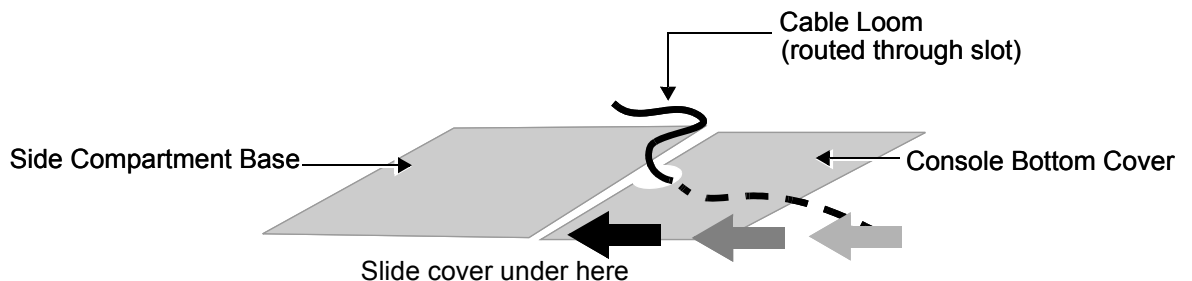

Figure 8-146 Routing Cable Loom through Slot in Console Bottom Cover (upper section)

- 22.) Screw the cover firmly in position as described in the [Control Console Bottom Cover \(Upper Section\) Installation Procedure](#) on page 8-19.
- 23.) Re-install the Connectors Panel Cover as described in the [Connector Panels Cover Installation Procedure](#) on page 8-8.
- 24) Reconnect the mains AC power cable from the wall outlet.
- 25) Turn ON the main circuit breaker located on rear of the Vivid™ 3.
- 26) Turn ON the Vivid™ 3 by pressing the ON/OFF button on the Control Console.
- 27.) Under System Configuration, VCR/ECG Tab, select the JVC VCR option. For more information, see [VCR/ECG Tab](#) on page 3-45.
- 28.) Insert a blank video cassette tape into the VCR and perform a test recording to check correct operation.

Note: JVC VCR - Reset Counter:

If the Reset Counter button is activated while the VCR is in the *Stop, Pause, or Record* state, the counter display is reset to *zero* (0:00:00).

8-8-4-6 JVC VCR Removal Procedure

- 1.) Remove the Connectors Panel cover as shown in the [Connector Panels Cover Removal Procedure](#) on page 8 - 8.
- 2.) Disconnect the RS-232C cable, the Audio and S-Video IN and OUT cables, and the Power cable from the Vivid™ 3 rear connectors panel - see [Figure 8-145](#) on page 8-149.
- 3.) Remove the aluminium VCR stopper from the edge of the side compartment on the *left* side of the Vivid™ 3 ultrasound unit (refer to [Figure 8-141](#) on page 8-147).
- 4.) Slide the VCR partially out of the compartment, carefully easing the attached cables with it.
- 5.) Disconnect the RS-232C cable, the Audio and S-Video IN and OUT cables from VCR rear connectors panel (refer to [Figure 8-136](#) on page 8-145).
- 6.) Disconnect the JVC VCR AC power cable extender from the power cable connector on the Vivid™ 3 (refer to [Figure 8-138](#) on page 8-146).
- 7.) When all cables are disconnected, remove the VCR completely from the Vivid™ 3 ultrasound unit.

8-8-5 Panasonic VCR Replacement Procedure

NOTE: This section describes the installation and removal procedure of the Panasonic AG-MD-835E (PAL) and AG-MD-835P (NTSC) video cassette recorders.

The installation and removal procedures are the same for both models.

NOTE: **IMPORTANT - Before installation of either Panasonic VCR model, it is necessary to order the Panasonic VCR RS-232 Adaptor (Part No. 066E8200).**



Figure 8-147 Panasonic Video Cassette Recorder (VCR)

8-8-5-1 Tools

No special tools needed.

8-8-5-2 Manpower

One person - 30 mins.

8-8-5-3 Preparations

- 1.) Shut down the Vivid™ 3 ultrasound unit, as described in [Chapter 3 - Installation](#).
- 2.) Remove the Connectors Panels Cover as described in the [Connector Panels Cover Removal Procedure](#) on page 8 - 8.
- 3.) Unpack the VCR.
- 4.) Check that the VCR AC voltage corresponds to that of your local voltage.
- 5.) Verify that the switches on the VCR front switch panel are as shown in [Figure 8-148](#) on page 8-152. If necessary, adjust accordingly.

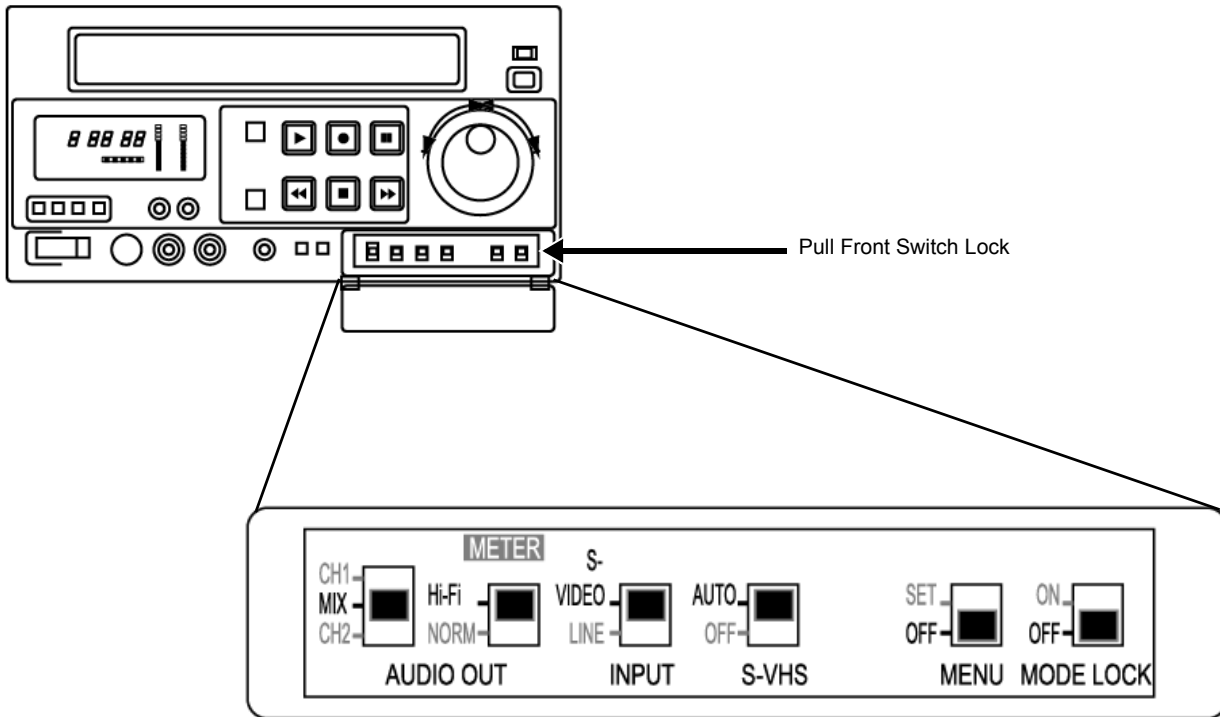

Figure 8-148 Panasonic VCR Switches Setting

8-8-5-4 Panasonic VCR Installation Procedure

- 1.) Raise the control console to *maximum* height.
- 2.) Place the VCR on the Vivid™ 3 ultrasound unit's top surface (*left side, below the control console, as shown in Figure 8-129 below*), allowing sufficient room to access the cables at the rear of the VCR.

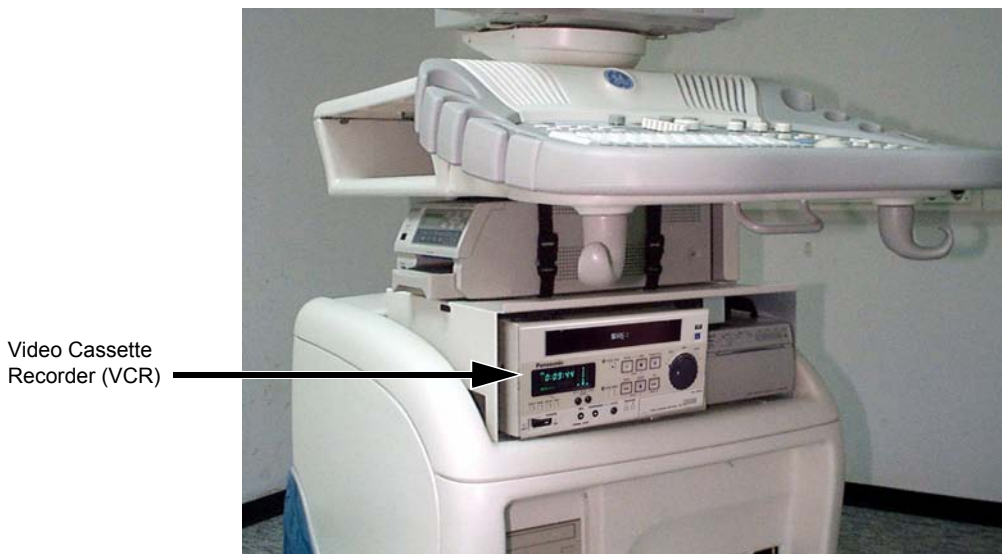

Figure 8-149 Panasonic Video Cassette Recorder (VCR) Installed in the Vivid™ 3 Ultrasound Unit

- 3.) Connect the Panasonic VCR RS-323 adaptor (Part No. 066E8200) to the RS-232C cable, and then to the RS-323 socket on the rear of the VCR, as shown in Figure 8-131 below.
- 4.) Connect the Audio and S-Video IN and OUT cables, and the Power cable (also shown in Figure 8-131).

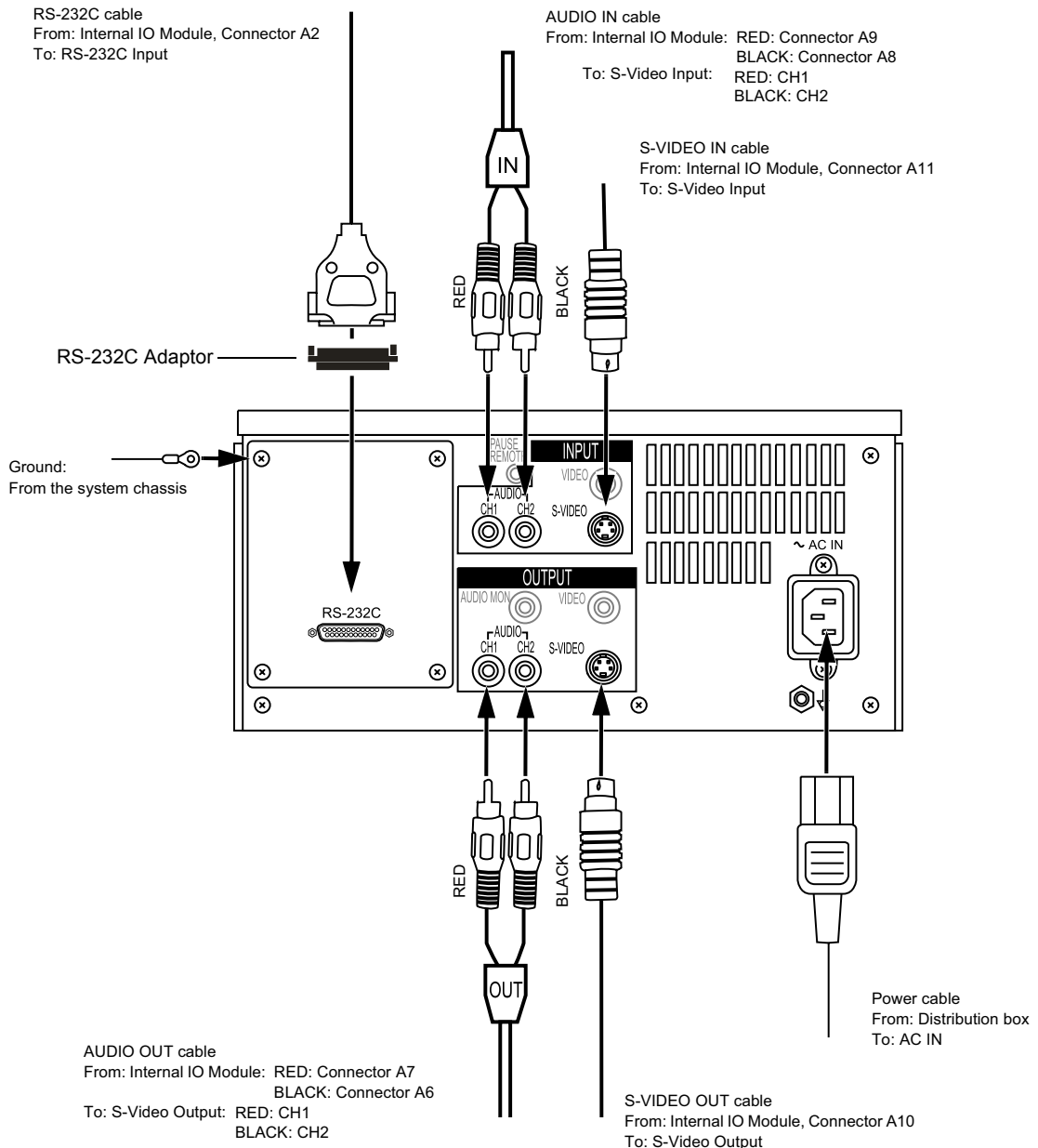

Figure 8-150 Panasonic VCR Connection Cables

- 5.) Place the VCR in its correct final position.
- 6.) Secure the VCR by fastening the belt around it, or together with the B/W Printer (if present).
- 7.) If more secure fastening is desired, install the optional shelf (P/N H45011CN), which can be ordered separately if the Color Printer option is not installed.

NOTE: For shelf installation instructions, see [Color Video Printer Installation - Procedure 1](#) on page 8 - 157.

- 8.) Re-install the Connectors Panels Cover as described in the [Connector Panels Cover Installation Procedure](#) on page 8 - 8.
- 9.) Reconnect the mains AC power cable from the wall outlet.
- 10) Turn ON the main circuit breaker located on rear of the Vivid™ 3.
- 11) Turn ON the Vivid™ 3 by pressing the ON/OFF button on the Control Console.
- 12.) Under System Configuration, VCR/ECG Tab, select the Panasonic VCR option, as shown in [Figure 8-151](#) below. For more information, see [VCR/ECG Tab](#) on page 3 - 45.

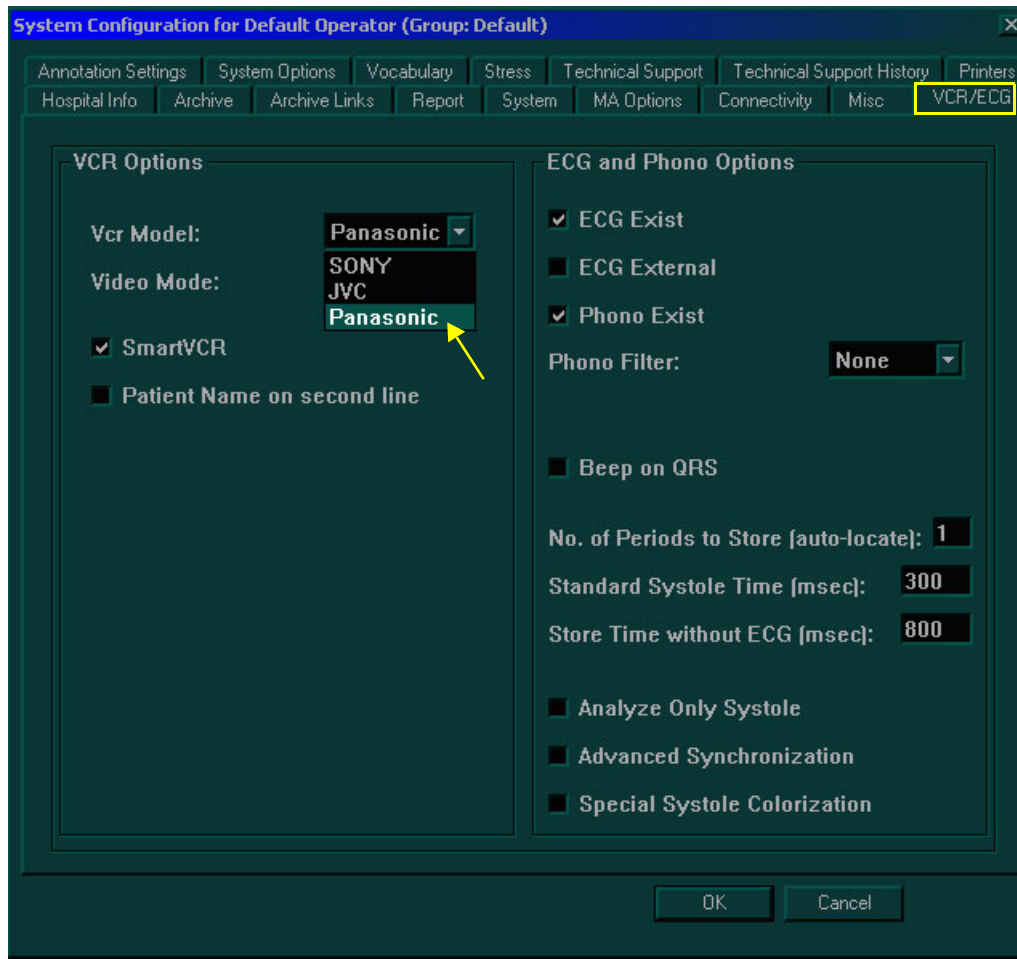

Figure 8-151 Panasonic VCR Option

Note: Panasonic VCR - Reset Counter:

If the Reset Counter button is activated while the VCR is in the *Stop* state, the counter display is reset to zero (0:00:00).
If activated in either the *Pause* or *Record* state, the display continues running (counter does not zero).

8-8-5-5 Panasonic VCR Removal Procedure

- 1.) Remove the Connectors Panels Cover as described in the [Connector Panels Cover Removal Procedure](#) on page 8 - 8.
- 2.) If optional shelf (P/N H45011CN) is present, refer to the [Color Video Printer Removal - Procedure 1](#) on page 8 - 161.
- 3.) Release the B/W printer by undoing the fastening belt around it (together with the VCR, if present).
- 4.) Disconnect the RS-232C cable (with adaptor), the Audio and S-Video IN and OUT cables, and the Power cable from the rear of the VCR as shown in [Figure 8-150](#) on page 8-153.
- 5.) Remove the VCR from the Vivid™ 3 ultrasound unit (taking it out from below the control console and from beside the B/W printer, if present) - refer to [Figure 8-129](#) on page 8-138.

8-8-6 Sony UP 2950 MD & 2800P Color Video Printer Replacement Procedure

NOTE: This section describes the installation and removal procedures of the Sony UP-2800P and UP/2950MD Color Video Printers.

The Sony UP-2950MD Color Video Printer has a NTSC/PAL Selector on the rear panel while the Sony UP-2800P Color Video Printer is PAL only.



Figure 8-152 SONY Color Video Printer

In this section, two types of replacement procedures are described, as follows:

- For units that are equipped with a previously-installed B/W printer and/or VCR (see [Color Video Printer Installation - Procedure 1](#) on page 8 - 157, and [Color Video Printer Removal - Procedure 1](#) on page 8 - 161).
- For units that are not equipped with a previously-installed B/W printer and/or VCR (refer to [Color Video Printer Installation - Procedure 2](#) on page 8 - 162, and [Color Video Printer Removal - Procedure 2](#) on page 8 - 162).

8-8-6-1 Tools

Use the appropriate flat and Phillips-type screw drivers.

8-8-6-2 Manpower

One person - 30 mins.

8-8-6-3 Preparations

- 1.) Shut down the Vivid™ 3 ultrasound unit, as described in [Chapter 3 - Installation](#).
- 2.) Remove the Connectors Panels Cover as described in the [Connector Panels Cover Removal Procedure](#) on page 8 - 8.
- 3.) Unpack the Color Video Printer.
- 4.) Check that the Color Video Printer AC voltage corresponds to that of your local voltage.
- 5.) Set the NTSC/PAL selector switch to NTSC (this applies only to Model UP-2950MD) as shown in [Figure 8-158](#) on page 8-160.
- 6.) Install the Color Video Printer accessories, as described in the Operating Instructions supplied with the printer.

8-8-6-4 Color Video Printer Installation - Procedure1

NOTE: The Installation Procedure is for units that are equipped with a previously-installed B/W printer and/or VCR. The color printer option includes a shelf with fastening belt, on which the printer is placed.

NOTE: If a B/W Printer and VCR are not installed, then the Color Video Printer can be placed on the top surface of the Vivid™ 3 ultrasound unit (below the keyboard) and secured with the belt.

- 1.) Raise the control console to its *maximum* height.
- 2.) If a B/W Printer and/or a VCR are installed, disconnect all the cables and remove the units.
- 3.) Remove the Metal Bottom Cover, beneath the front part of the control console, as described in the [Control Console Bottom Cover \(Upper Section\) Replacement Procedure](#) on page 8 - 17.
- 4.) Remove the Compartment Tray as described in the [Gas Spring Removal Procedure](#) on page 8 - 111
- 5.) Remove the Compartment Base as described in the [Control Console Bottom Cover \(Upper Section\) Removal Procedure](#) on page 8 - 17
- 6.) Route the Color Printer cables, found in the compartment, and let them drop down through the opening left after the Metal Bottom Cover was removed (see [step 3](#), above).
- 7.) Re-install the Metal Bottom Cover, as described in the [Control Console Bottom Cover \(Upper Section\) Installation Procedure](#) on page 8 - 19.

Note: Make sure that all the cables are fitted through the slot in the far end of the Metal Bottom Cover, as shown in [Figure 8-153](#) below.



Figure 8-153 Color Printer Cables through Metal Bottom Cover Slot

- 8) Remove the *right* and *left* screws located at the front of the lower section top cover, as shown in [Figure 8-154](#) on page 8-158.

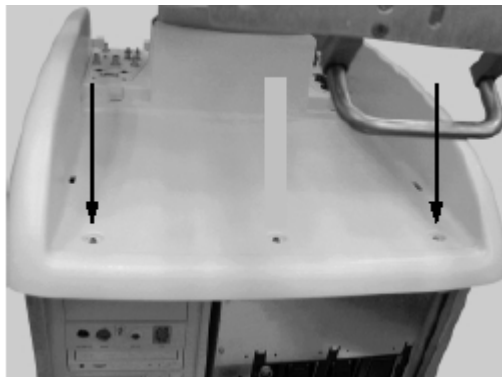

Figure 8-154 Top Cover Screws

- 9) Place the shelf on the top surface, with its two legs facing the front, and the stoppers (located on top of the shelf) facing the far end. Fasten the shelf to the top surface, using the screws removed in [step 8](#), as shown in [Figure 8-155](#).

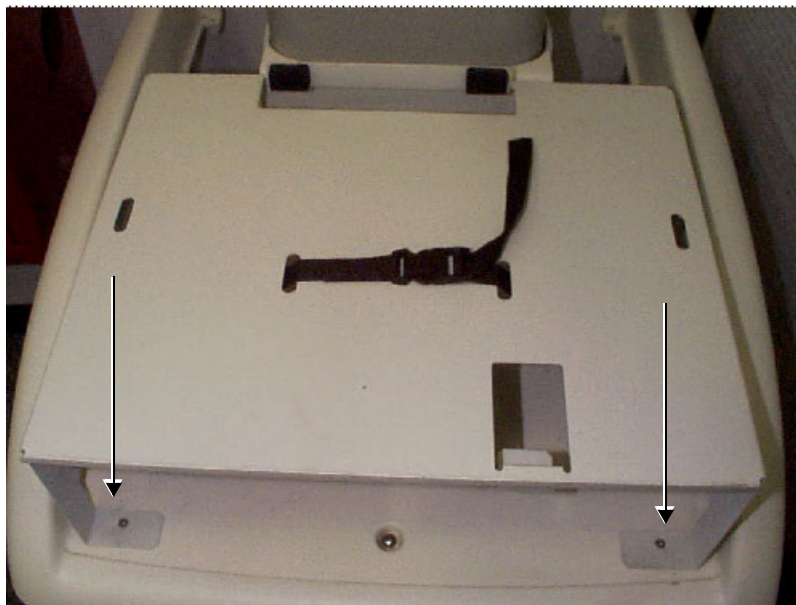

Figure 8-155 Shelf Fastened to Top Cover

- 10) Route the *left* end of the top surface belt through the narrow *left* slot in the shelf (closest to the front), working from below the shelf, *upwards*.
- 11) Route the *right* end of the top surface belt through the narrow *right* slot in the shelf (closest to the front), working from below the shelf, *upwards*.
- 12) Route the two sections of the additional belt (supplied with the Color Printer Shelf), through the second pair of (outer) *right* and *left* slots, as shown in [Figure 8-155](#), above.
- 13) Return the B/W printer and VCR to their original positions, between the left and right sections of the belt.
- 14) Lock the belt buckles to tighten the shelf to the top surface. Verify that the B/W printer and VCR are secure.

- 15.) Re-connect the previously-disconnected B/W Printer and VCR cables.
- 16) Place the Color Video Printer on top of the shelf, allowing sufficient room to access the cables at the rear of the printer, as shown in [Figure 8-156](#) below.

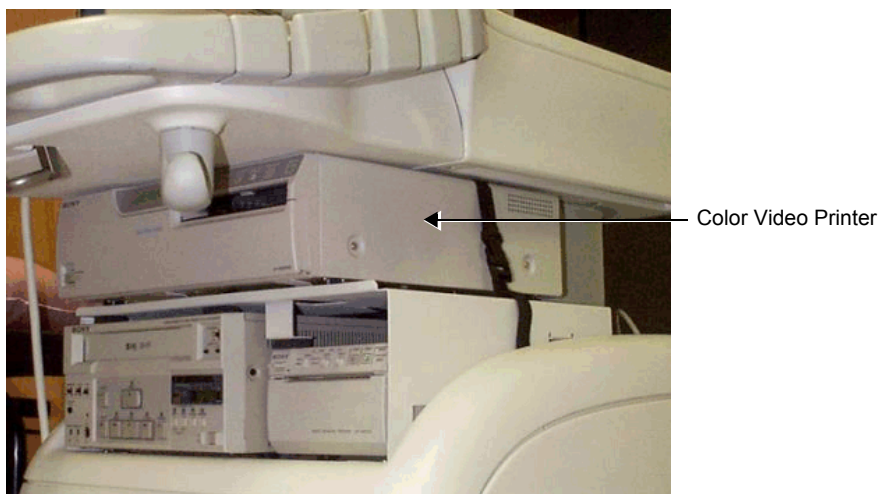

Figure 8-156 Color Video Printer and Shelf Installed on the Vivid™ 3

- 17.) Connect the Ground cable (hanging out of the Bottom Metal Cover) to the Ground screw at the rear of the Color Video Printer, as shown in [Figure 8-157](#) below

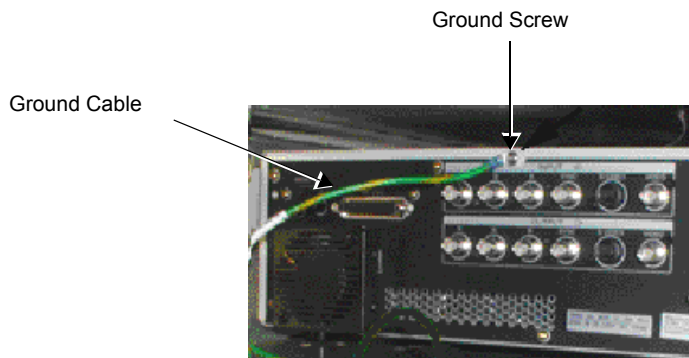

Figure 8-157 Color Video Printer Ground Cable Connection

- 18) Connect the RGB and SYNC cables, Color Printer Remote cable, and AC power cable (hanging out of the Bottom Metal Cover slot - see [Figure 8-153](#) on page 8-157), to the Color Video Printer, as shown in the diagram in [Figure 8-158](#) on page 8-160.

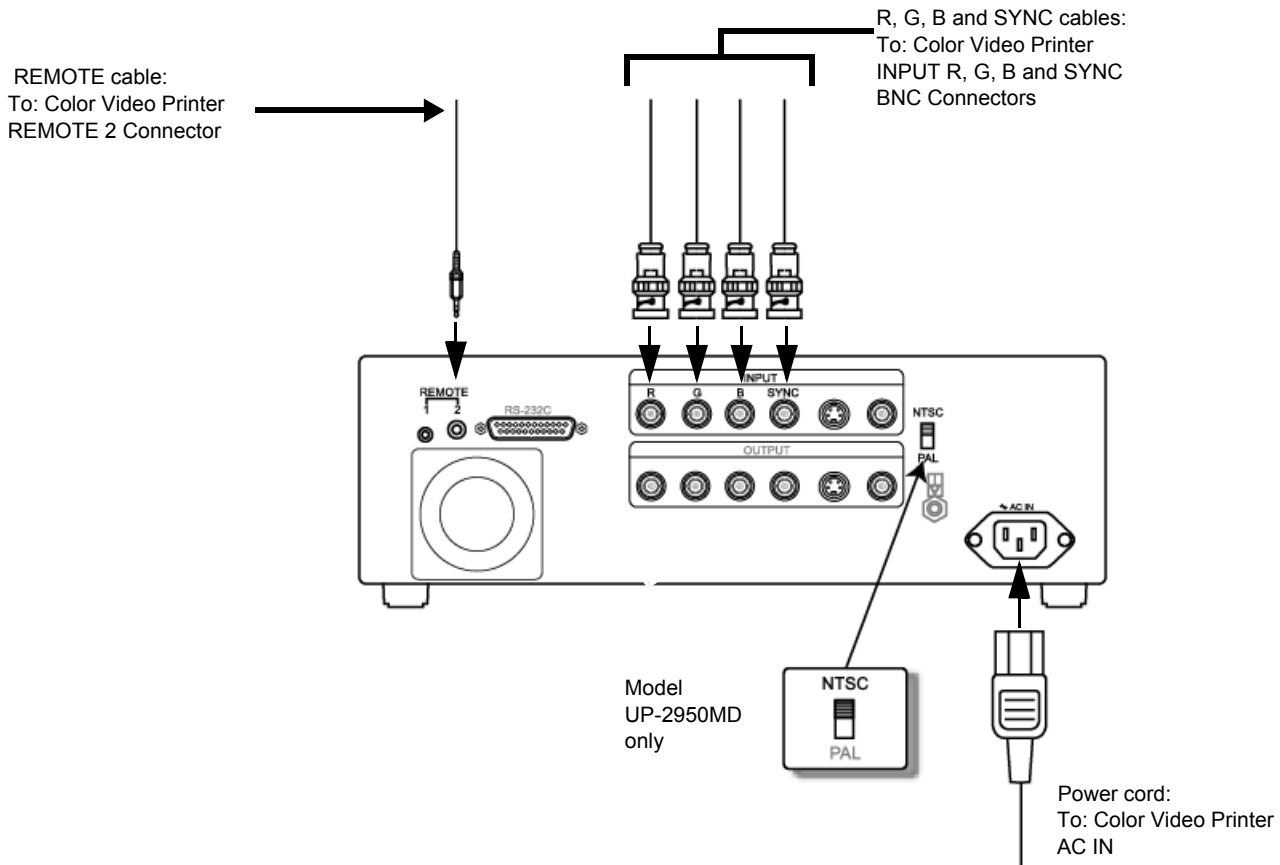

Figure 8-158 Color Video Printer Connection Cables

- 19.) Position the Color Video Printer against the rubber stoppers at the rear of the shelf.
 - 20.) Connect the buckles and tighten the belt. Verify that the Color Video Printer is secure.
 - 21.) Re-install the Connectors Panels Cover as described in the [Connector Panels Cover Installation Procedure](#) on page 8 - 8.
 - 22.) Reconnect the mains AC power cable from the wall outlet.
 - 23.) Turn ON the main circuit breaker located on rear of the Vivid™ 3.
 - 24.) Turn ON the Vivid™ 3 by pressing the ON/OFF button on the Control Console.
 - 25.) Select the activation key under System Configuration, VCR/ECG Tab, A/B Swap.
By default, Print B key will be B&W Video printer and Print A key will be Color Video printer. For more information on switching printer settings, see [VCR/ECG Tab](#) on page 3 - 45.
- See also the [Color Video Printer Settings](#) section, page 8-163.

8-8-6-5 Color Video Printer Removal - Procedure 1

NOTE: This procedure (Procedure 1) is for units that are equipped with a previously-installed B&W printer and a VCR. The color printer option includes a metal shelf and fastening belt on which the color printer is placed.

- 1) Unlock the belt buckles located on either side of the color printer.

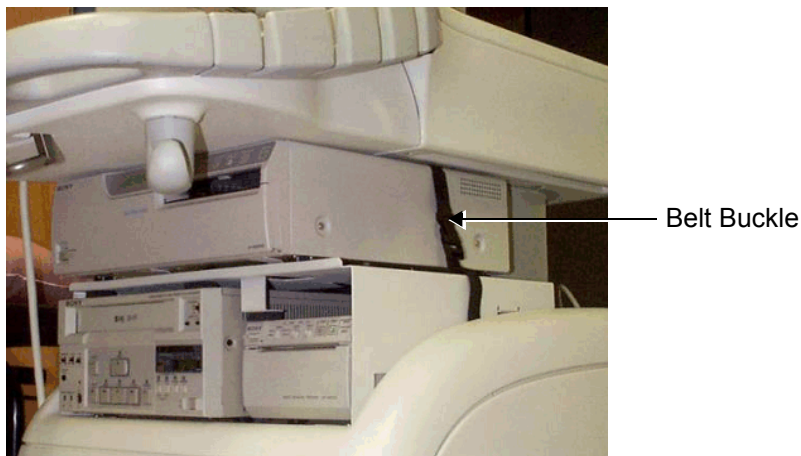

Figure 8-159 Belt Buckles Securing Printer

- 2) Move the color printer forwards, to gain access to the rear panel.
- 3) Open the *lower middle* screw from the color printer's rear panel and remove the Ground cable lug.
- 4) Unplug the AC cable.
- 5) Unplug the BNC connectors R-G-B and SYNC from the color printer.
- 6) Remove the color printer from the top shelf.

Note: Perform the following steps *only* if the metal shelf must be removed.

- 7) Remove the *right* and *left* screws located in the legs on either side of the shelf, and remove the shelf.

Note: Do not perform the following step if the metal shelf will later be replaced.

- 8) Return and fasten the two screws (removed in [step 7](#)) to either side of the top cover.

8-8-6-6 Color Video Printer Installation - Procedure 2

NOTE: *This procedure (Installation Procedure 2) is for units that are not equipped with a previously-installed B&W printer and VCR. It describes all steps required to install a color printer. The color printer is placed on the top cover of the unit's lower section and the additional shelf and belt supplied with the color printer are not required.*

- 1) Unlock the belt buckles located on the lower section of the unit's top cover, and move the belt parts to the sides.
- 2) Place the color printer on the lower section of the top cover.
- 3) Connect the cable's BNC connectors R-G-B and SYNC to the color printer R-G-B and SYNC Input connectors.
- 4) Plug the color printer remote cable to the color printer Remote 2 Input.
- 5) Plug the AC cable to the color printer AC IN socket.
- 6) Screw the Ground cable lug to the lower middle screw on the color printer's rear panel.
- 7) Set the NTSC/PAL switch in accordance with your local color system.
- 8) Lock the belt buckles over the color printer, and tighten the belt by pulling the remaining length of the belt to fasten the printer securely in position.
- 9) Reconnect the mains AC power cable from the wall outlet.
- 10) Turn ON the main circuit breaker located on rear of the Vivid™ 3.
- 11) Turn ON the Vivid™ 3 by pressing the ON/OFF button on the Control Console.
- 12.) Select the activation key under System Configuration, VCR/ECG Tab, A/B Swap.
By default, Print B key will be B&W Video printer and Print A key will be Color Video printer. For more information on switching printer settings, see [VCR/ECG Tab](#) on page 3 - 45.
See also the [Color Video Printer Settings](#) section, page 8-163.

8-8-6-7 Color Video Printer Removal - Procedure 2

NOTE: *This procedure (Removal Procedure 2) is for units that are not equipped with a previously-installed B&W printer and a VCR.*

- 1) Unlock the belt buckles located on either side of the color printer, as shown in [Figure 8-159](#) on page 8-161.
- 2) Move the color printer forward to access its rear panel.
- 3) Open the lower middle screw on the color printer's rear panel and remove the Ground cable lug.
- 4) Unplug the AC cable.
- 5) Unplug the cable's BNC connectors R-G-B and SYNC from the color printer RGB and SYNC Input connectors.
- 6) Remove the color printer.

8-8-6-8 Color Video Printer Settings

NOTE: The settings for the Sony UP-2800P and UP2950MD Color Video Printers are regulated using the Video Printer Control Panel, as described below.

8-8-6-8-1 Preparations

- 1.) Turn ON the main circuit breaker located on rear of the Vivid™ 3.
- 2.) Turn ON the Vivid™ 3 by pressing the ON/OFF button on the Control Console.
- 3.) Open the front door of the Color Video Printer.
- 4.) Press MENU.
The Preset menu is displayed (see Figure 8-160 below).
There are five setup categories: COLOR (c), LAYOUT (l), PRINTER (p), INPUT (i) and OUTPUT (o). Each setup category can be selected from the Top menu of each category.

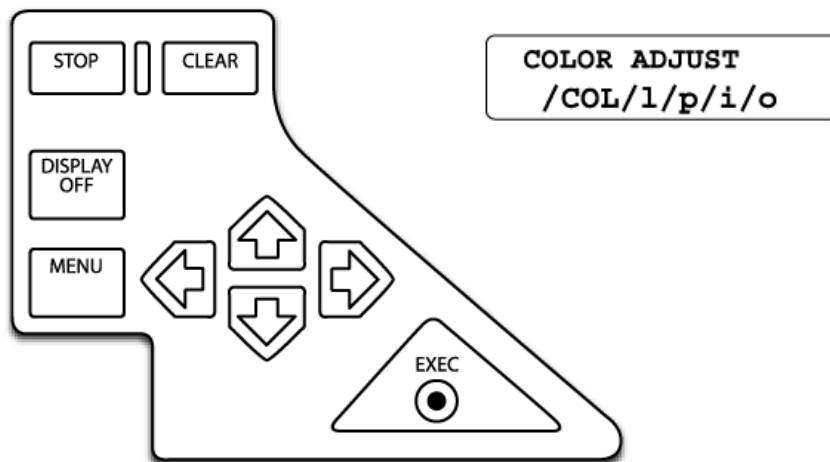



Figure 8-160 Color Video Printer Control Panel and Printer Window Display

8-8-6-8-2 Color Setup

- 1.) Select COL using the  or  button (see Figure 8-160, above). The COLOR ADJUST top menu is displayed on the Printer Window display (Figure 8-161 below).

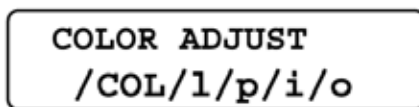

Figure 8-161 Color Video Printer Window Display (COLOR ADJUST top menu displayed)







- 2.) In the COLOR ADJUST menu, adjust the required parameters (according to those shown in Table 8-8 on page 8-164) by selecting the parameters one-by-one, using the  or  button; for each selected parameter, adjust the value using the  or  button.

Table 8-7 COLOR SETUP Parameters

Parameter	Setting for PAL	Setting for NTSC
DARK	-2	-5
LIGHT	0	+2

3.) Press EXEC on the Printer Control Panel to save the Color settings.

8-8-6-8-3 Layout Setup

- 1.) Return to the COLOR ADJUST top menu (Figure 8-161 on page 8-163)), using the  button.
- 2.) Select LAY by pressing the  or  button. The LAYOUT SETUP top menu is displayed (Figure 8-162 below).

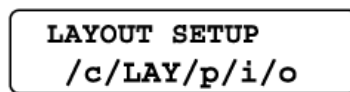





Figure 8-162 Color Video Printer Window Display (LAYOUT SETUP top menu displayed)

- 3.) In the LAYOUT SETUP menu, select WINDOW by pressing the  or  button.
- 4.) Press the  button to display the WINDOW SETUP menu (Figure 8-163 below).

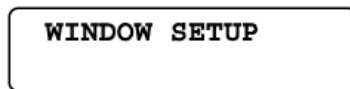

Figure 8-163 Color Video Printer Window Display (WINDOW SETUP top menu displayed)









- 5.) In the WINDOW SETUP menu, adjust the required parameters (in accordance with those shown in Table 8-8 below) by selecting the parameters one-by-one using the  or  button; for each selected parameter, adjust the value using the  or  button.

Table 8-8 WINDOW SETUP Parameters

Parameter	Setting for PAL	Setting for NTSC
H START	-8	-16
V START	-8	-8
H WIDTH	816	832
V WIDTH	568	480

8-8-6-8-4 Printer Setup

- 1.) Return to the WINDOW SETUP top menu using the  button (Figure 8-163, above).
- 2.) Press the  button to display the LAYOUT SETUP menu (Figure 8-162).

- 3.) Select PRN by using the  or  button. The PRINTER SETUP top menu is displayed:

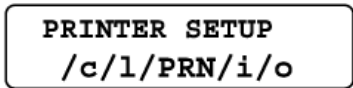





Figure 8-164 Color Video Printer Window Display (PRINTER SETUP top menu displayed)

- 4.) In the PRINTER SETUP menu, select FUNCTION using the  or  button.
- 5.) Press the  button to display the FUNCTION SETUP menu:

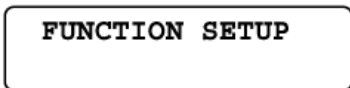

Figure 8-165 Color Video Printer Window Display (FUNCTION SETUP top menu displayed)







- 6.) In the FUNCTION SETUP menu, adjust the parameters in accordance with those shown in [Table 8-9](#) below, by selecting the parameters one-by-one using the  or  button; for each selected parameter, adjust the value using the  or  button.

Table 8-9 FUNCTION SETUP Parameters

Parameter	Setting (PAL and NTSC)
AUTO LIVE	ON
RM2 FUNC	C&PRINT

8-8-6-8-5 Input Setup

- 1.) Return to the PRINTER SETUP top menu using the  button ([Figure 8-164](#), above).
- 2.) Select IN by using the  or  button. The INPUT SETUP top menu is displayed:

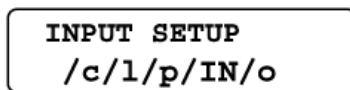







Figure 8-166 Color Video Printer Window Display (INPUT SETUP top menu displayed)

- 3.) In the INPUT SETUP menu, select INPUT SEL using the  button.
- 4.) Adjust INPUT SEL to RGB by using the  or  button.
This setting applies to both PAL and NTSC models.

8-8-6-8-6 Output Setup

- 1.) Return to the INPUT SETUP top menu using the  button (Figure 8-166).
- 2.) Select OUT by using the  or  button. The OUTPUT SETUP top menu is displayed:

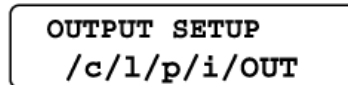

Figure 8-167 Color Video Printer Window Display (OUTPUT SETUP top menu displayed)





- 3.) In the OUTPUT SETUP menu, adjust the parameters in accordance with those shown in Table 8-10 below, by selecting the parameters one-by-one using the  or  button; for each selected parameter, adjust the value using the  or  button.

Table 8-10 OUTPUT SETUP Parameters

Parameter	Setting (PAL and NTSC)
DISPLAY	ON
SYNC ON G	ON
SOURCE	EE

- 4.) Press EXEC on the control panel of the printer to save the settings.

8-8-7 Sony UP-21MD Color Video Printer Replacement Procedure

NOTE: This section describes the installation and removal procedures of the Sony UP-21MD Color Video Printer.

The Sony UP-21MD Color Video Printer has an NTSC/PAL Selector on the rear panel.



Figure 8-168 SONY UP-21MD Color Video Printer

In this section, two types of replacement procedures are described, as follows:

- For units that are equipped with a previously-installed B/W printer and/or VCR
(see [Color Video Printer Installation - Procedure 1](#) on page 8 - 157, and [Color Video Printer Removal - Procedure 1](#) on page 8 - 161).
- For units that are not equipped with a previously-installed B/W printer and/or VCR
(refer to [Color Video Printer Installation - Procedure 2](#) on page 8 - 162, and [Color Video Printer Removal - Procedure 2](#) on page 8 - 162).

8-8-7-1 Tools

Use the appropriate flat and Phillips-type screw drivers.

8-8-7-2 Manpower

One person - 30 mins.

8-8-7-3 Preparations

- 1.) Shut down the Vivid™ 3 ultrasound unit, as described in [Chapter 3 - Installation](#).
- 2.) Remove the Connectors Panels Cover as described in the [Connector Panels Cover Removal Procedure](#) on page 8 - 8.
- 3.) Unpack the Color Video Printer.
- 4.) Set the NTSC/PAL selector switch to PAL or NTSC as shown in [Figure 8-166](#) on page 8-165.
- 5.) Install the Color Video Printer accessories, as described in the Operating Instructions supplied with the printer.

8-8-7-4 Sony UP-21MD Color Video Printer Installation - Procedure1

NOTE: *The Installation Procedure is for units that are equipped with a previously-installed B/W printer and/or VCR. The color printer option includes a shelf with fastening belt, on which the printer is placed.*

NOTE: *If a B/W Printer and VCR are not installed, then the Color Video Printer can be placed on the top surface of the Vivid™ 3 ultrasound unit (below the keyboard) and secured with the belt.*

- 1.) Raise the control console to its *maximum* height.
- 2.) If a B/W Printer and/or a VCR are installed, disconnect all the cables and remove the units.
- 3.) Remove the Metal Bottom Cover, beneath the front part of the control console, as described in the [Control Console Bottom Cover \(Upper Section\) Removal Procedure](#) on page 8 - 17.
- 4.) Remove the Compartment Tray as described in the [Gas Spring Removal Procedure](#) on page 8 - 111.
- 5.) Remove the Compartment Base as described in the [Control Console Bottom Cover \(Upper Section\) Removal Procedure](#) on page 8 - 17.
- 6.) Route the Color Printer cables, found in the compartment, and let them drop down through the opening left after the Metal Bottom Cover was removed (see [step 3](#), above).
- 7.) Re-install the Metal Bottom Cover, as described in the [Control Console Bottom Cover \(Upper Section\) Installation Procedure](#) on page 8 - 19.

Note: Make sure that all the cables are fitted through the slot in the far end of the Metal Bottom Cover, as shown in [Figure 8-169](#) below.



Figure 8-169 Color Printer Cables through Metal Bottom Cover Slot

- 8.) Remove the *right* and *left* screws located at the front of the lower section top cover, as shown in [Figure 8-170](#).

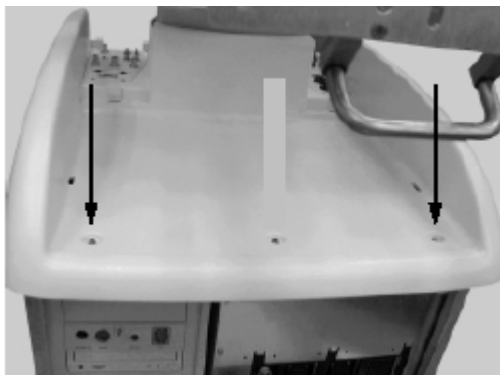

Figure 8-170 Top Cover Screws

- 9) Place the protective metal cover on top of the printer shelf (either on the *right* or *left* side, as preferred by the customer) and fasten securely into position to protect the connectors, using the two screws provided - see [Figure 8-171](#) below:

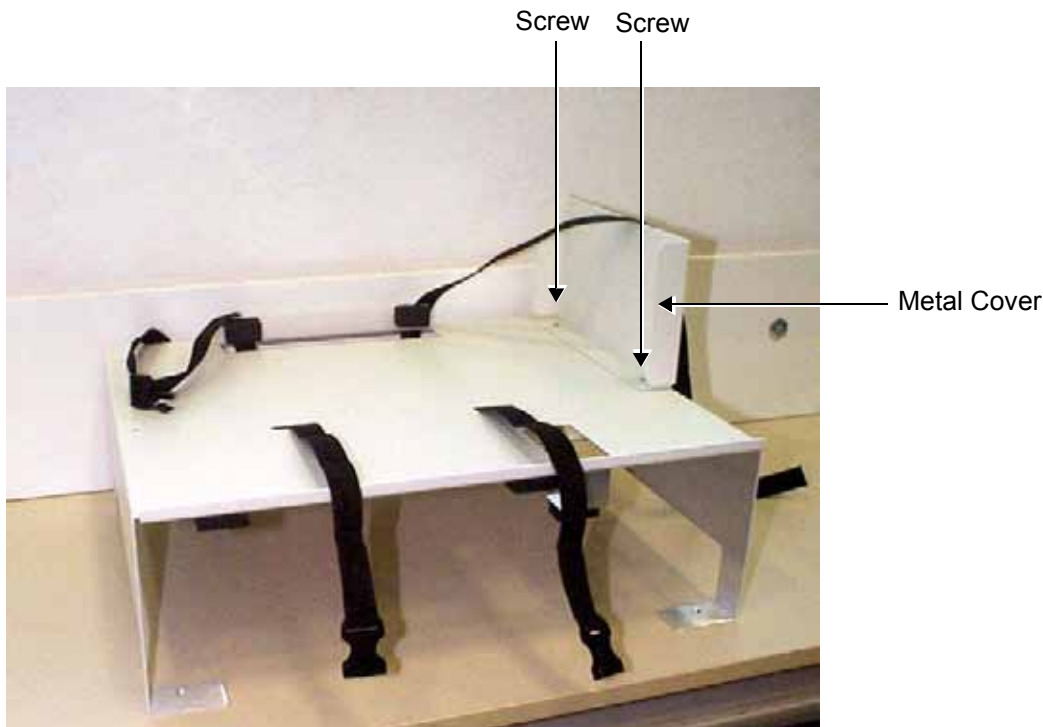

Figure 8-171 Printer Shelf with Protective Metal Cover Secured in Position

- 10) Place the shelf on the top surface, with its two legs facing the front, and the stoppers (located on top of the shelf) facing the far end. Fasten the shelf to the top surface, using the screws removed in [step 8](#), as shown in [Figure 8-172](#) below.

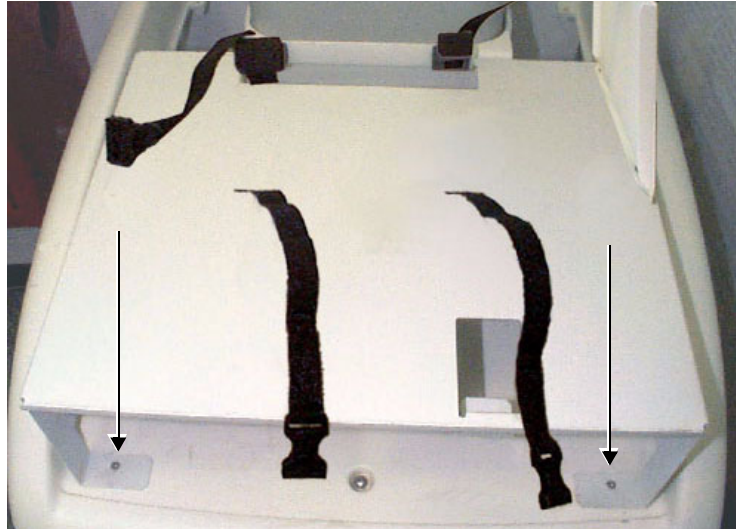

Figure 8-172 Shelf Fastened to Top Cover

- 11.) Route the end of one of the top surface securing belts down through the narrow *left* slot in the shelf (closest to the front), then thread it below the shelf, *backwards* and *upwards* through the slot at the rear of the shelf. Leave the opposite end of the belt (with the plastic buckle [female end] attached) dangling towards the front, as shown in [Figure 8-171](#) and [Figure 8-172](#) on page 8-170.
- 12) Repeat [step 11](#) to thread the second belt in position through the slot on the *right*.
- 13) Attach the male end of the two plastic buckles to each of the belt ends protruding from the rear *right* and *left* slots.
- 14) Return the color printer and VCR to their original positions, between the left and right sections of the belt.
- 15) Lock the belt buckles to tighten the shelf to the top surface. Verify that the printer and VCR are secure.
- 16.) Re-connect the previously-disconnected Color Printer and VCR cables.
- 17) Place the UP-21MD Color Video Printer on top of the shelf, as shown in [Figure 8-173](#) below.

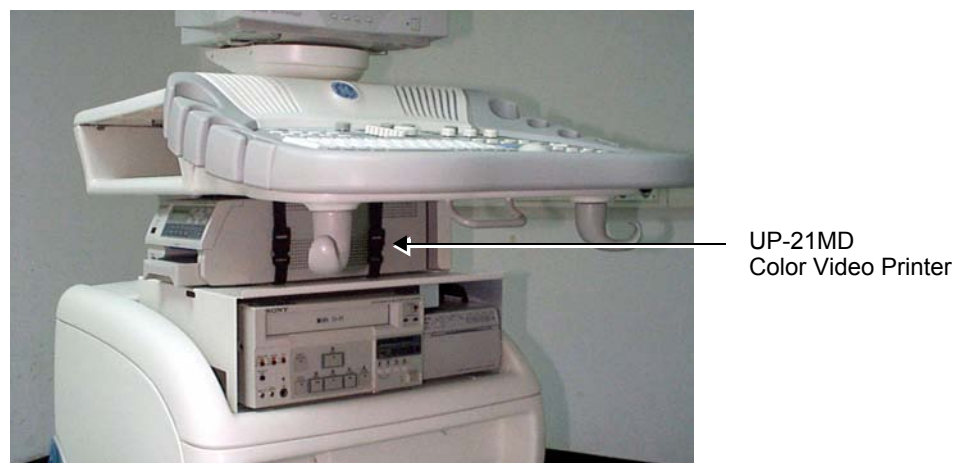

Figure 8-173 Sony UP-21MD Color Video Printer and Shelf Installed on the Vivid™ 3

- 18.) Connect the Ground cable (hanging out of the Bottom Metal Cover) to the Ground screw at the rear of the UP-21MD Color Video Printer, as shown in [Figure 1-17](#) below

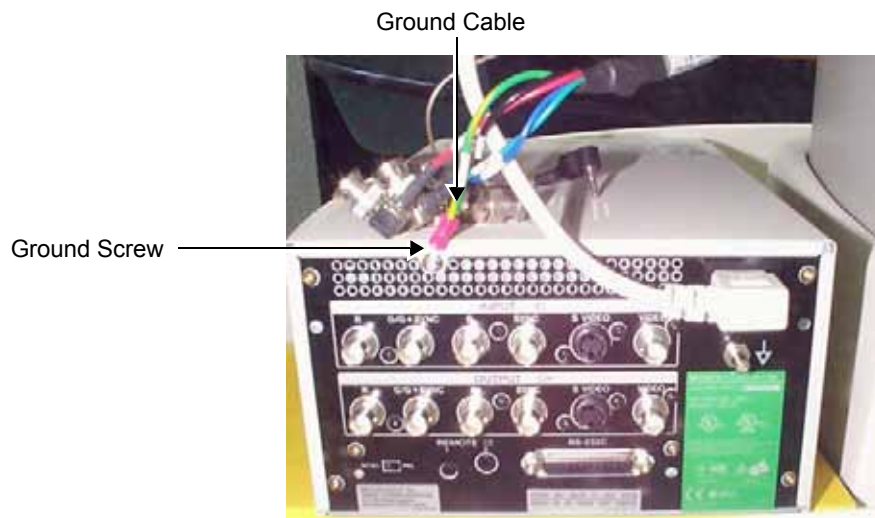

Figure 8-174 UP-21MD Color Video Printer Ground Cable Connection

- 19) Connect the RGB and SYNC cables, Color Printer Remote cable, and AC power cable (hanging out of the Bottom Metal Cover slot - see [Figure 8-169](#) on page 8-168), to the UP-21MD Color Video Printer, as shown in the diagram in [Figure 8-175](#) on page 8-172.

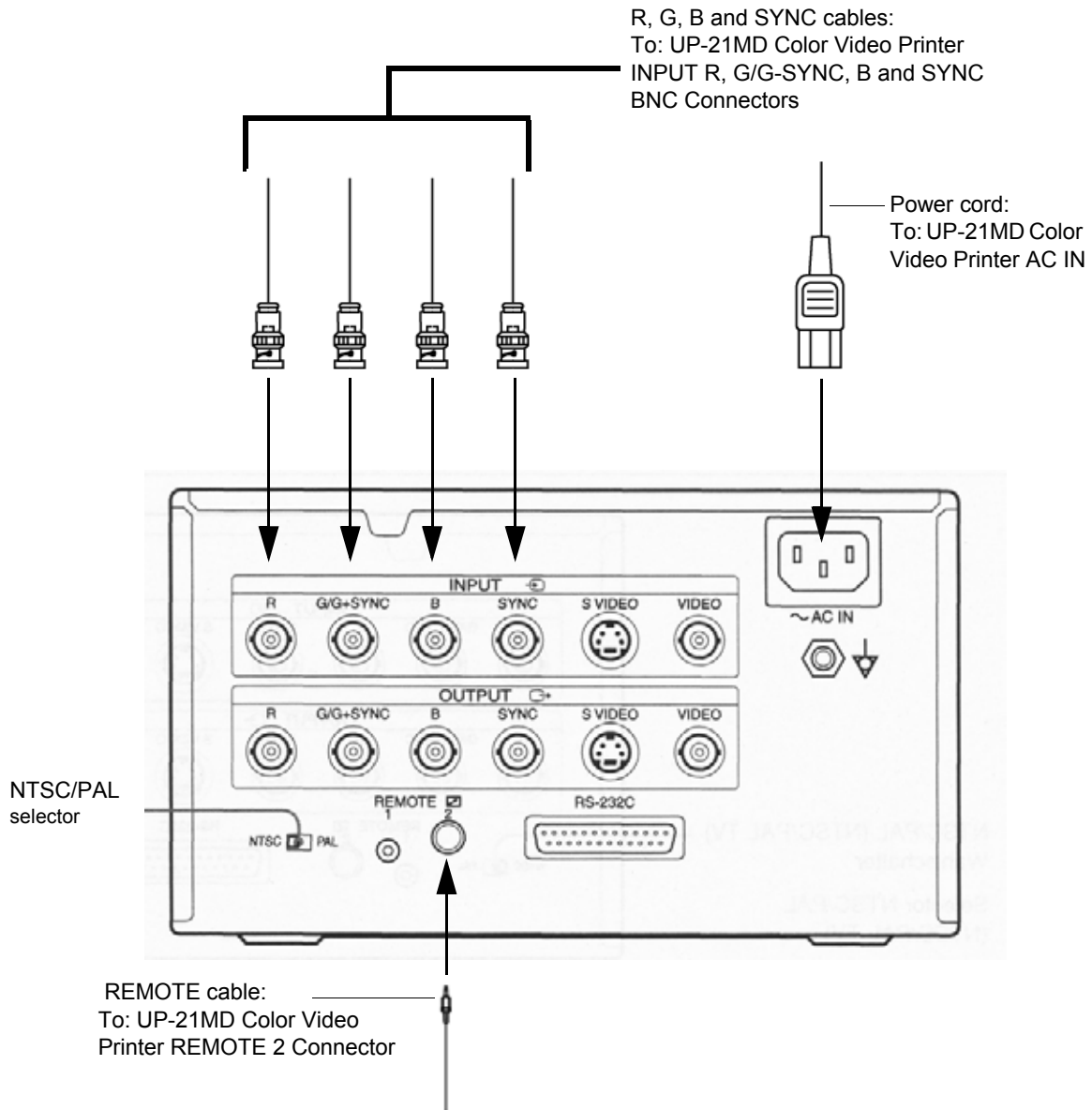

Figure 8-175 Sony UP-21MD Color Video Printer Connection Cables

- 20.) Position the Color Video Printer against the rubber stoppers at the rear of the shelf, and against the metal protective cover on the side (making sure that the connectors are not exposed).
- 21.) Connect the two plastic buckles and tighten the belts. Verify that the UP-21MD Color Video Printer is secure.

- 22.) Re-install the Connectors Panels Cover as described in the [Connector Panels Cover Installation Procedure](#) on page 8 - 8.
- 23) Reconnect the mains AC power cable from the wall outlet.
- 24) Turn ON the main circuit breaker located on rear of the Vivid™ 3.
- 25) Turn ON the Vivid™ 3 by pressing the ON/OFF button on the Control Console.
- 26.) Select the activation key under System Configuration, VCR/ECG Tab, A/B Swap.
By default, Print B key will be B&W Video printer and Print A key will be Color Video printer. For more information on switching printer settings, see [VCR/ECG Tab](#) on page 3 - 45.

8-8-7-5 Sony UP 21MD Color Video Printer Removal - Procedure 1

NOTE: This procedure (Procedure 1) is for units that are equipped with a previously-installed B&W printer and a VCR. The color printer option includes a metal shelf and fastening belt on which the color printer is placed.

- 1.) Unlock the belt buckles securing the color printer.



Figure 8-176 Belt Buckles Securing Printer

- 2.) Move the color printer *sideways*, to gain access to the rear panel.
- 3.) Open the *lower middle* screw from the color printer's rear panel and remove the Ground cable lug.
- 4.) Unplug the AC cable.
- 5.) Unplug the BNC connectors R-G-B and SYNC from the color printer.
- 6.) Remove the color printer from the top shelf.

Note: Perform the following steps *only* if the metal shelf must be removed.

- 7.) Remove the *right* and *left* screws located in the legs on either side of the shelf, and remove the shelf.

Note: Do not perform the following step if the metal shelf will later be replaced.

- 8.) Return and fasten the two screws (removed in [step 7](#)) to either side of the top cover.

8-8-7-6 Sony UP-21MD Color Video Printer Installation - Procedure 2

NOTE: *This procedure (Installation Procedure 2) is for units that are not equipped with a previously-installed B&W printer and VCR. It describes all steps required to install a color printer. The color printer is placed on the top cover of the unit's lower section and the additional shelf and belt supplied with the color printer are not required.*

- 1) Unlock the belt buckles located on the lower section of the unit's top cover, and move the belt parts to the sides.
- 2) Place the color printer on the lower section of the top cover.
- 3) Connect the cable's BNC connectors R-G-B and SYNC to the color printer R-G-B and SYNC Input connectors.
- 4) Plug the color printer remote cable to the color printer Remote 2 Input.
- 5) Plug the AC cable to the color printer AC IN socket.
- 6) Screw the Ground cable lug to the lower middle screw on the color printer's rear panel.
- 7) Set the NTSC/PAL switch in accordance with your local color system.
- 8) Lock the belt buckles over the color printer, and tighten each belt by pulling the remaining length of the belt to fasten the printer securely in position.
- 9) Reconnect the mains AC power cable from the wall outlet.
- 10) Turn ON the main circuit breaker located on rear of the Vivid™ 3.
- 11) Turn ON the Vivid™ 3 by pressing the ON/OFF button on the Control Console.
- 12.) Select the activation key under System Configuration, VCR/ECG Tab, A/B Swap.
By default, Print B key will be B&W Video printer and Print A key will be Color Video printer. For more information on switching printer settings, see [VCR/ECG Tab](#) on page 3 - 45.

8-8-7-7 Sony UP 21MD Color Video Printer Removal - Procedure 2

NOTE: *This procedure (Removal Procedure 2) is for units that are not equipped with a previously-installed B&W printer and a VCR.*

- 1) Unlock the belt buckles located on either side of the color printer, as shown in [Figure 8-176](#) on page 8-173.
- 2) Move the color printer sideways to access its rear panel.
- 3) Open the lower middle screw on the color printer's rear panel and remove the Ground cable lug.
- 4) Unplug the AC cable.
- 5) Unplug the cable's BNC connectors R-G-B and SYNC from the color printer RGB and SYNC Input connectors.
- 6) Remove the color printer.

8-8-8 HP 6540/3 USB Deskjet Color Printer Replacement Procedure for Vivid™ 3 BT03 Systems

NOTE: *IMPORTANT - Whether the Vivid 3 system is currently using 3.3, 4.3, 3.6 or 4.6 software, it is necessary to install the printer driver, as described in the [HP 6540/3 USB Deskjet Color Printer Installation Procedure](#) below.*



Figure 8-177 HP 6540/3 USB Deskjet Color Printer

The HP6540/3 Printer Kit (P/N: 2415435) contains the following items:

Item Part No.	Description
2415380	HP6540 Printer
2415381-2	CD installation for HP-6540/3 Printer
2300847-3	Printer Power Cable
2415481-2	Installation Instructions

8-8-8-1 Tools

Use the appropriate flat and Phillips-type screw drivers.

8-8-8-2 Manpower

One person - 15 mins.

8-8-8-3 Preparations

- 1) Shut down the Vivid™ 3 ultrasound unit, as described in [Chapter 3 - Installation](#).
- 2.) Remove the Connectors Panels Cover as described in the [Connector Panels Cover Removal Procedure](#) on page 8 - 8.
- 3.) Carefully unpack the HP 6540/3 USB Printer.
- 4.) Check that the HP 6540/3 USB Printer AC voltage corresponds to that of your local voltage.

8-8-8-4 HP 6540/3 USB Deskjet Color Printer Installation Procedure

- 1.) Place the HP6540/3 USB Deskjet Color Printer on the Vivid 3 bottom shelf allowing sufficient room to access the cables at the rear of the printer, or on a stable surface located not far from the Vivid 3 scanner.
- 2.) Connect one end of the Printer power cable to the Vivid 3 rear connectors panel and the other end (via the transformer [supplied]) to the Low Voltage Power-IN socket on the rear of the printer, as shown in [Figure 8-178](#) below.

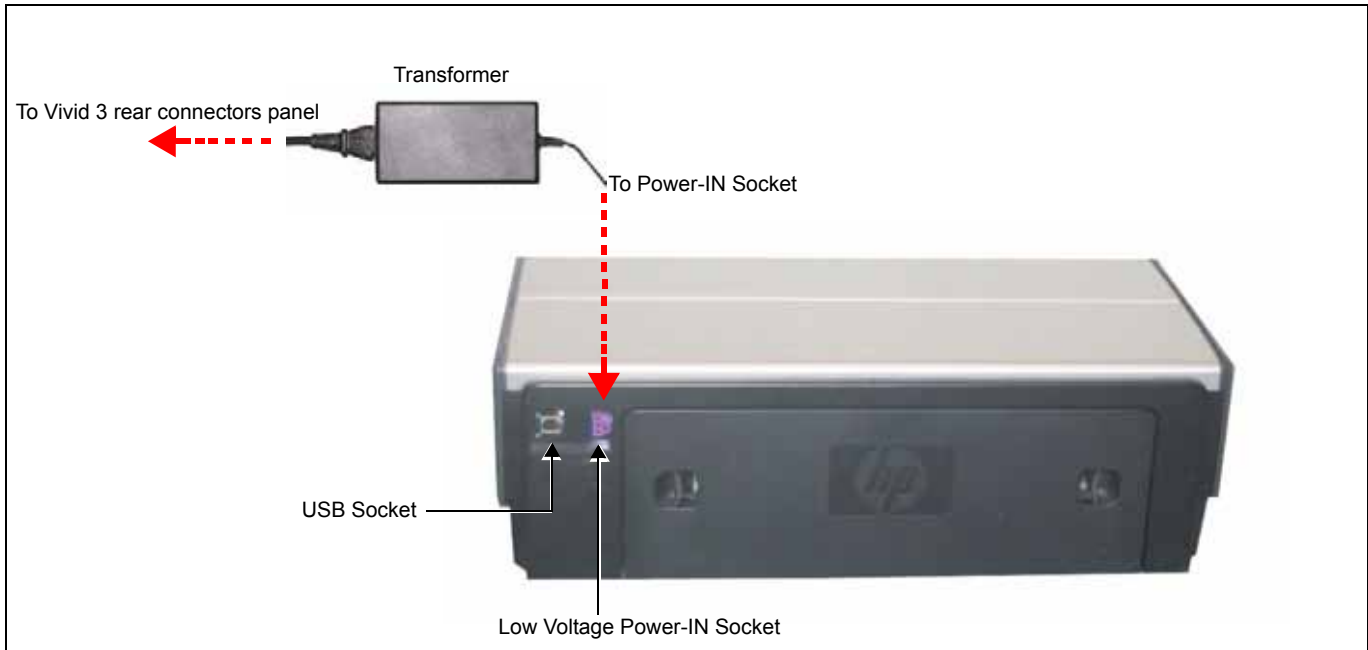

Figure 8-178 HP 6540/3 Deskjet Color Printer- Rear View



WARNING: To avoid electrical hazards, the HP 6540/3 USB Deskjet Color Printer must be connected to the AC Supply of the Vivid™ 3 Ultrasound Unit and never directly to the local AC wall outlet.

- 3.) Use the USB cable (shipped with the printer) to connect the Vivid 3 system to the USB socket on the HP6540/3 rear panel (see [Figure 8-178](#)).
- 4.) Turn ON power to the system and the printer and boot up the system in *User* mode.
- 5.) Wait until the application finishes loading and then press <Alt> +<Tab> simultaneously.

6.) When the *Found New Hardware Wizard* opens, click **Cancel**, see [Figure 8-179](#) below.

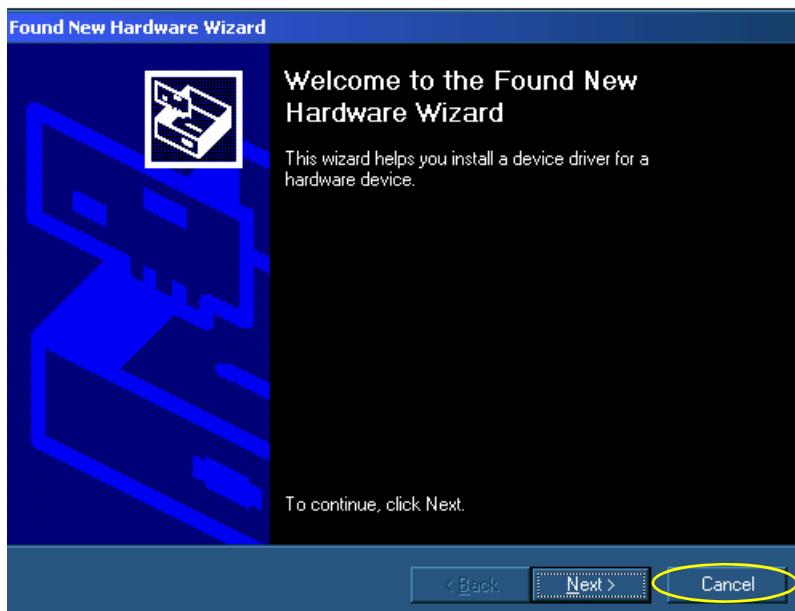

Figure 8-179 Found New Hardware Wizard

- 7.) Insert the HP6540/3 driver installation CD (P/N:2415381) provided with the printer into the CD-ROM drive.
- 8.) Browse the CD (Drive H:) and double-click on the *InstallPrinter.bat* file ([Figure 8-180](#))

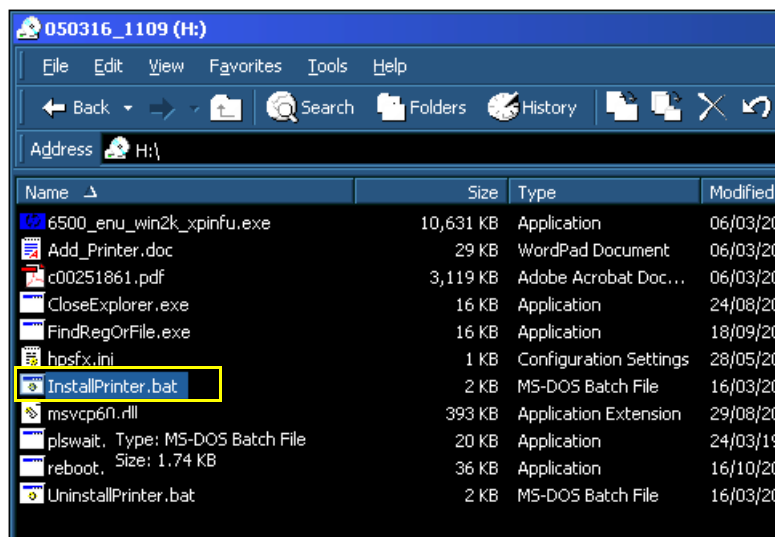

Figure 8-180 Install Printer

The printer installation process will begin - see [Figure 8-181](#).

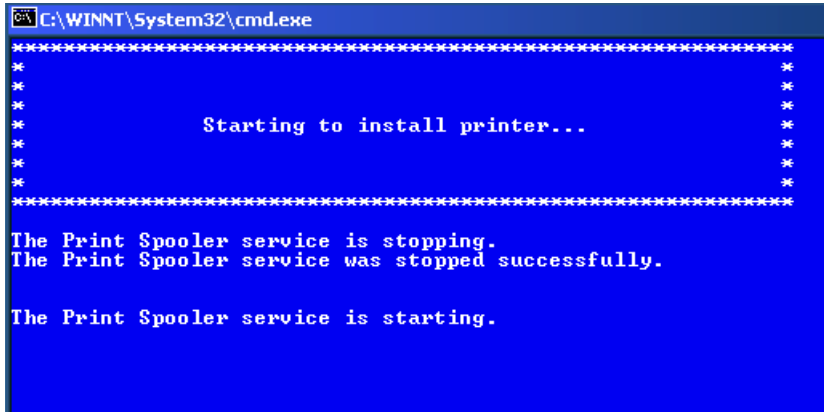

Figure 8-181 Printer Installation Process Commences

9.) When the *Add Printer Wizard* opens, click **Next** - see Figure 8-182.

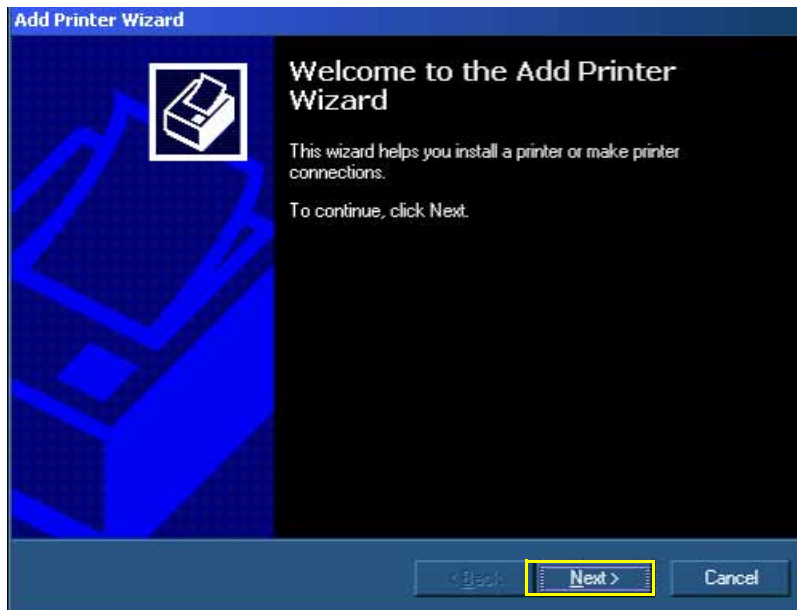

Figure 8-182 Add Printer Wizard

10.) When prompted, verify that *Local Printer* is selected. If not, activate the **Local printer** radio button as shown in Figure 8-183.

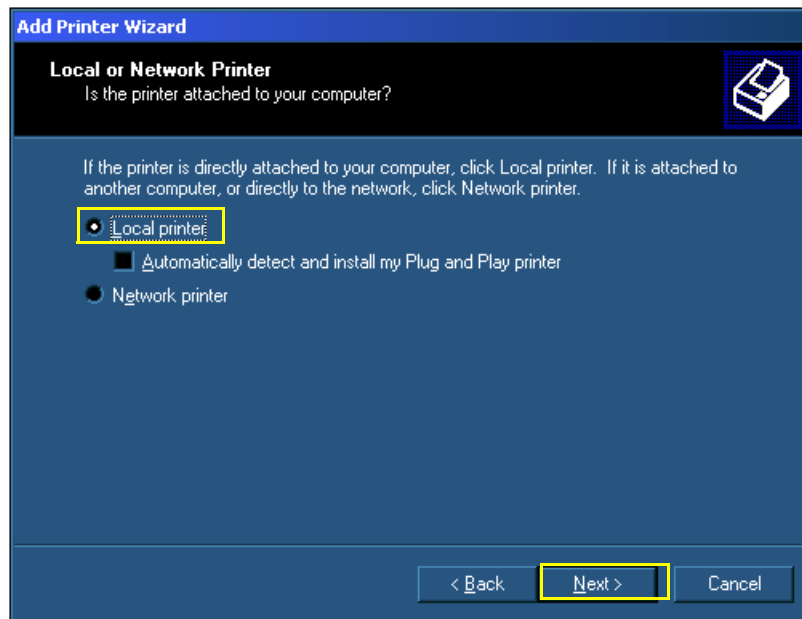

Figure 8-183 Verify Local Printer

11.) Click **Next**.

12.) From the displayed list of available ports, choose one of the available USB ports, as shown in [Figure 8-184](#).

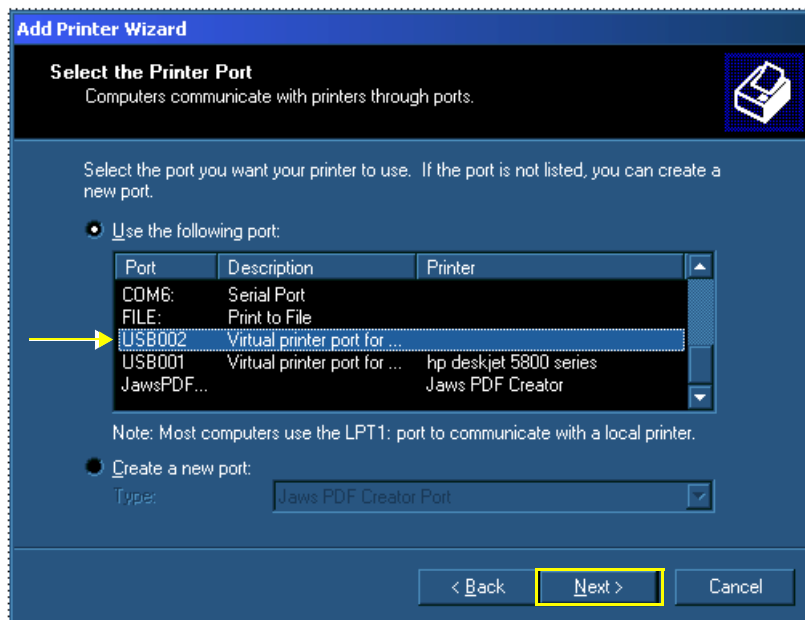

Figure 8-184 Choosing Available USB Port

13.) Click **Next**.

14.) From the list of Printers, highlight the **HP Deskjet 6500 Series** - see [Figure 8-185](#).

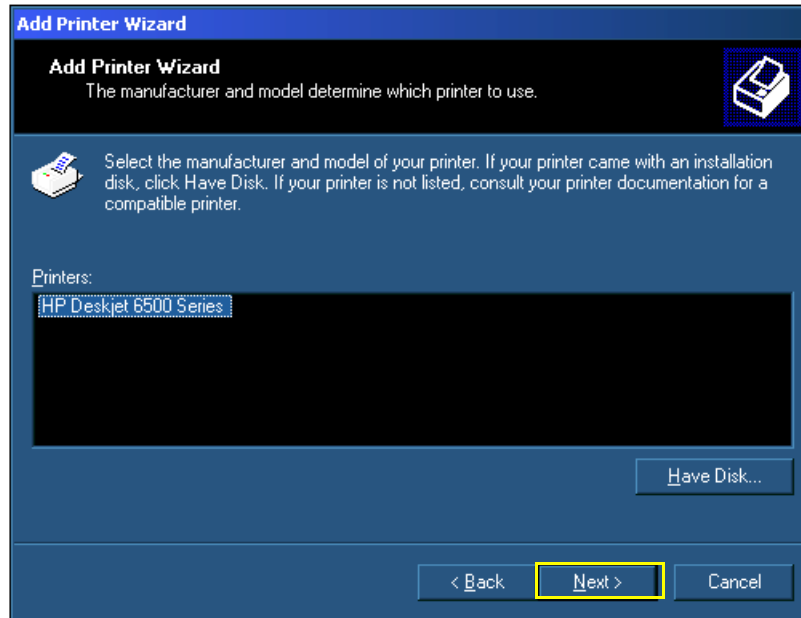

Figure 8-185 Printer Manufacturer and Model

15.) Click **Next**.

16.) When prompted, choose **Yes** if you want this printer to be the default printer - see [Figure 8-186](#).

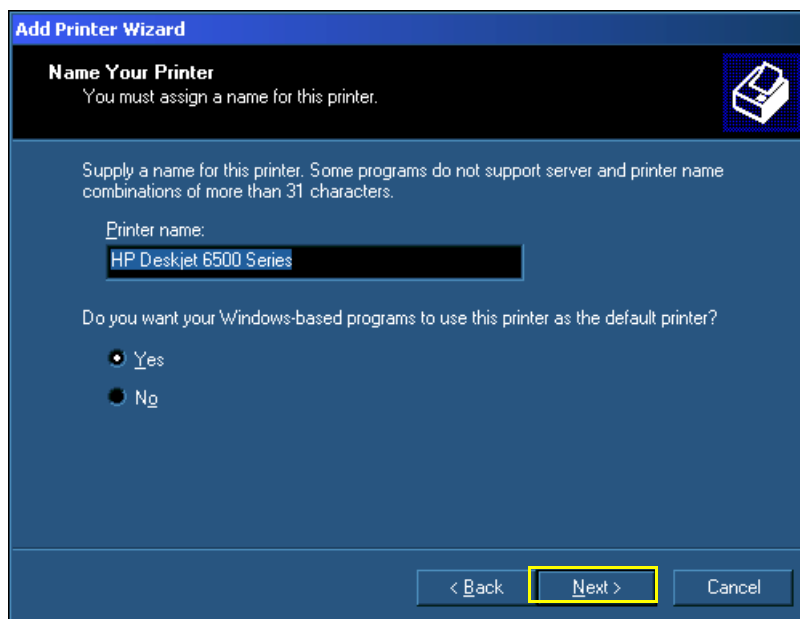

Figure 8-186 Choosing Default Printer

17.) Click **Next**.

18.)When the following message appears, verify that **Do not share this printer** is selected, as shown in [Figure 8-187](#).

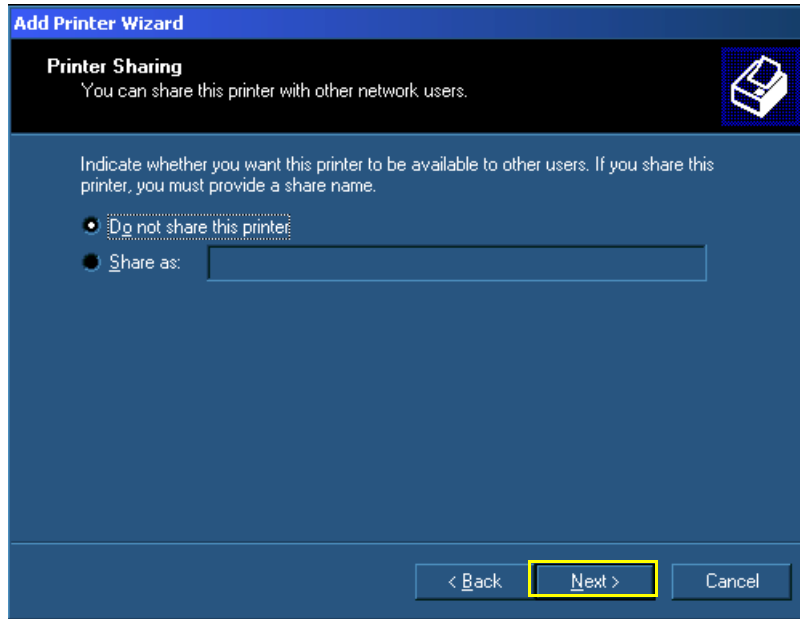

Figure 8-187 Printer Sharing Message

19.)Click **Next**.

20.)In response to the *Print a test page?* message, choose **No** and then click **Next** - see [Figure 8-188](#).

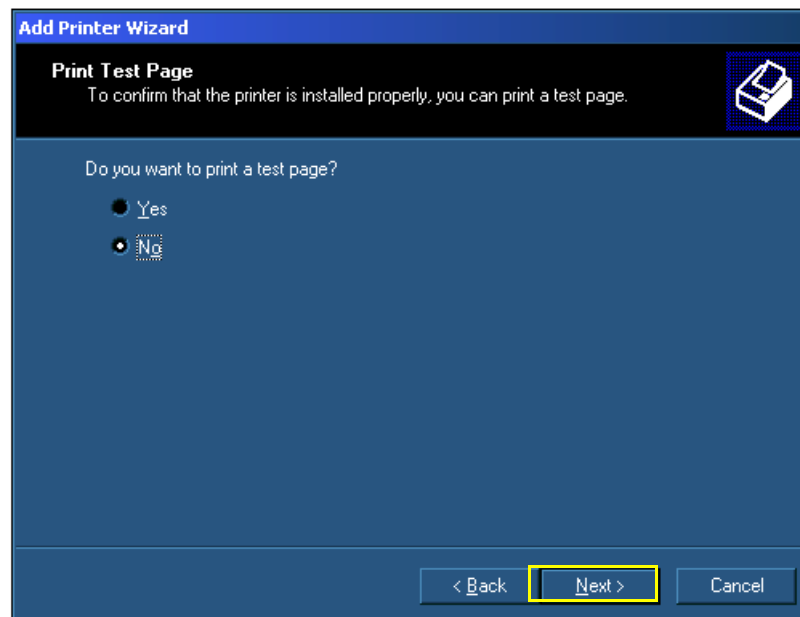

Figure 8-188 Print Test Page Message

The *Add Printer Wizard* displays the following message:

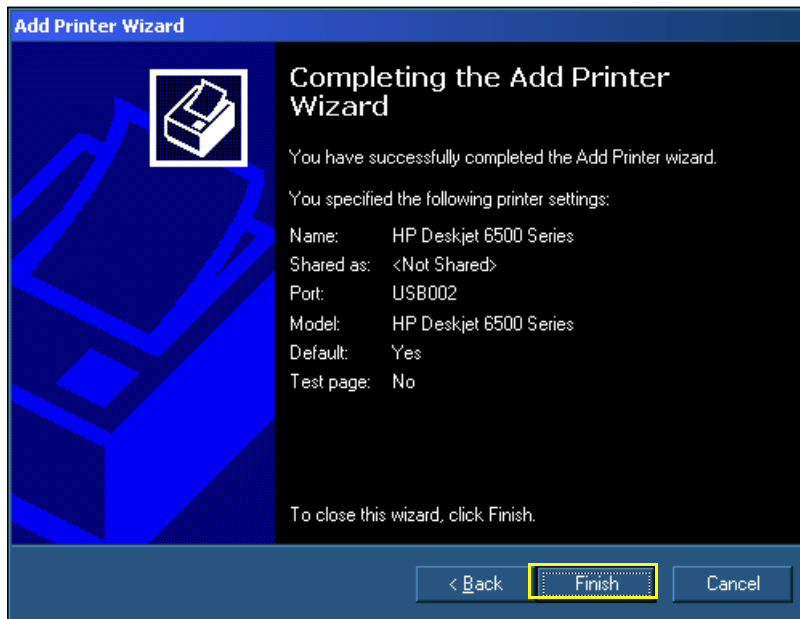

Figure 8-189 New Printer Added

21.) Click **Finish** to close the Wizard.

The Printer Properties Dialog opens with the *General Tab* activated, as shown in [Figure 8-190](#).

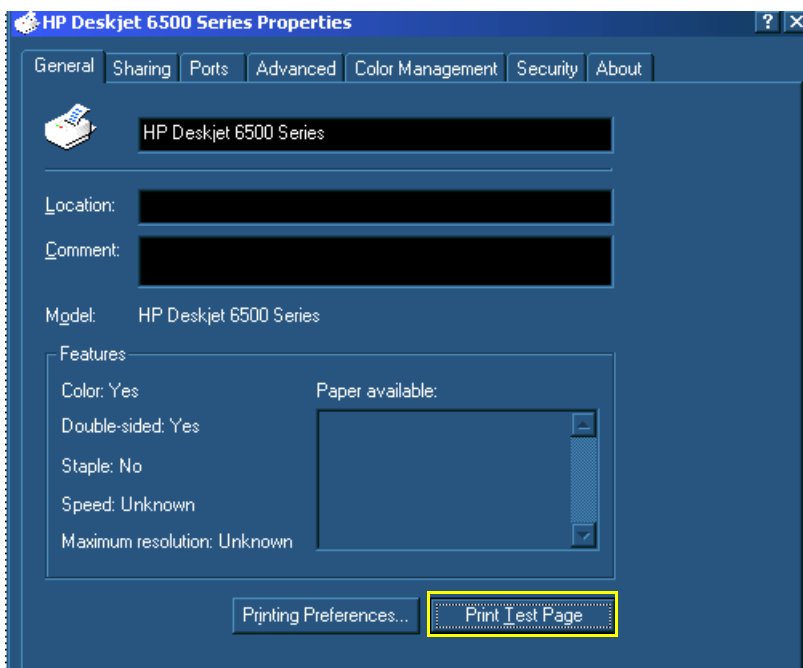

Figure 8-190 Printer Properties Dialog Box - General Tab

22.) Click on **Print Test Page**.

The following message is displayed:

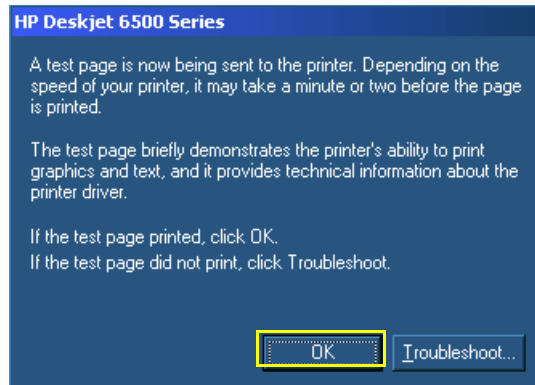

Figure 8-191 Test Page Printing

23.) Confirm that test page was printed properly, then click **OK**.

The Printer Properties Dialog opens with the *Ports Tab* activated, as shown in [Figure 8-192](#).

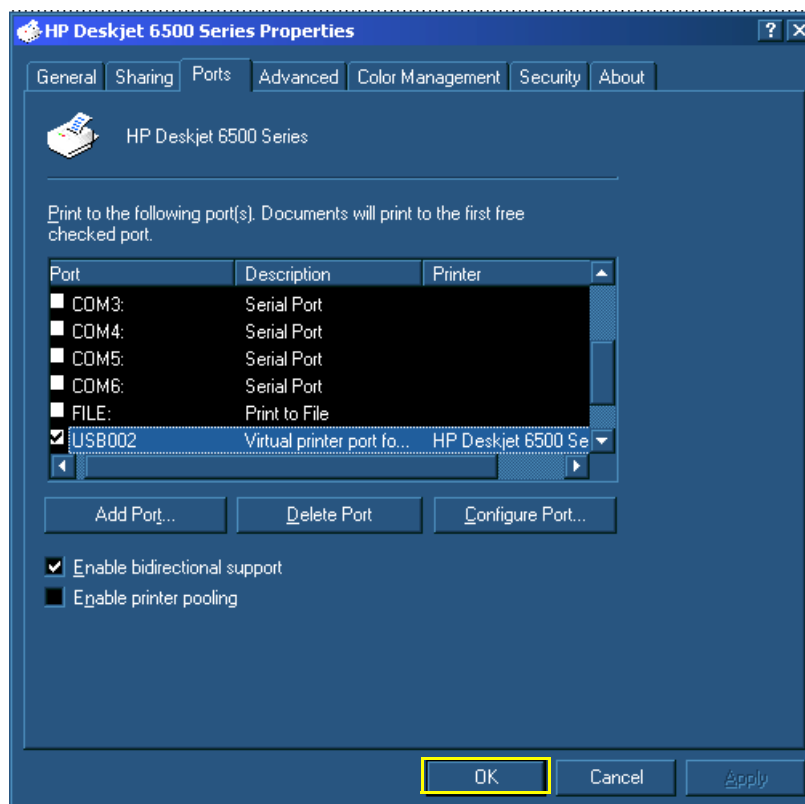

Figure 8-192 Printer Properties Dialog Box - Ports Tab

24.) Confirm that a USB port is selected for the printer, then click **OK**.

The Printer Properties Dialog opens with the *Advanced Tab* activated, as shown in [Figure 8-193](#).

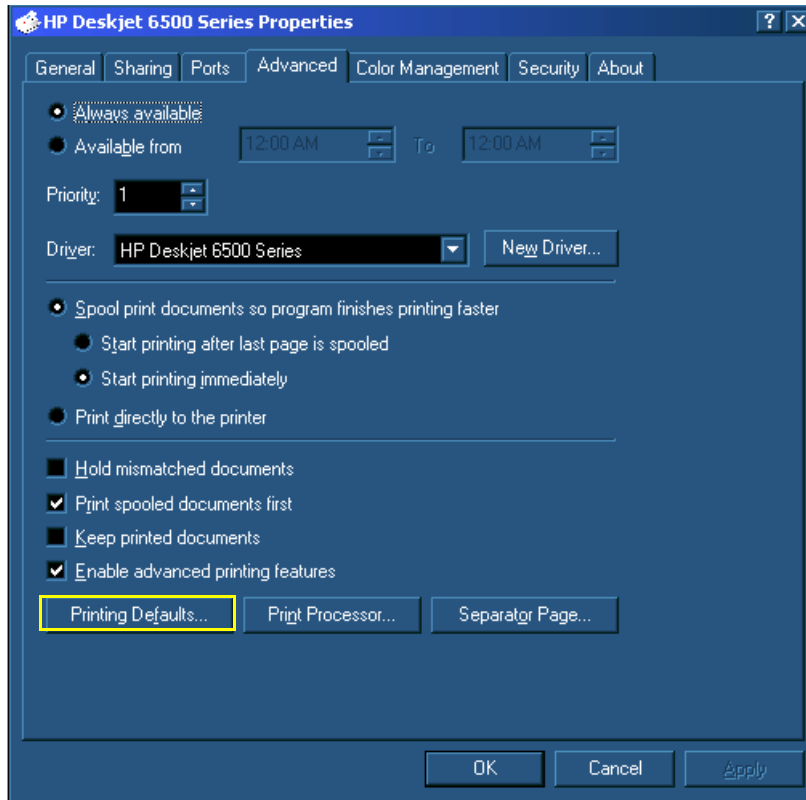

Figure 8-193 Printer Properties Dialog Box - Advanced Tab

25.) Click on **Printing Defaults**.

The Printing Defaults dialog box opens with the *Printing Shortcuts* tab activated, as shown in [Figure 8-194](#).

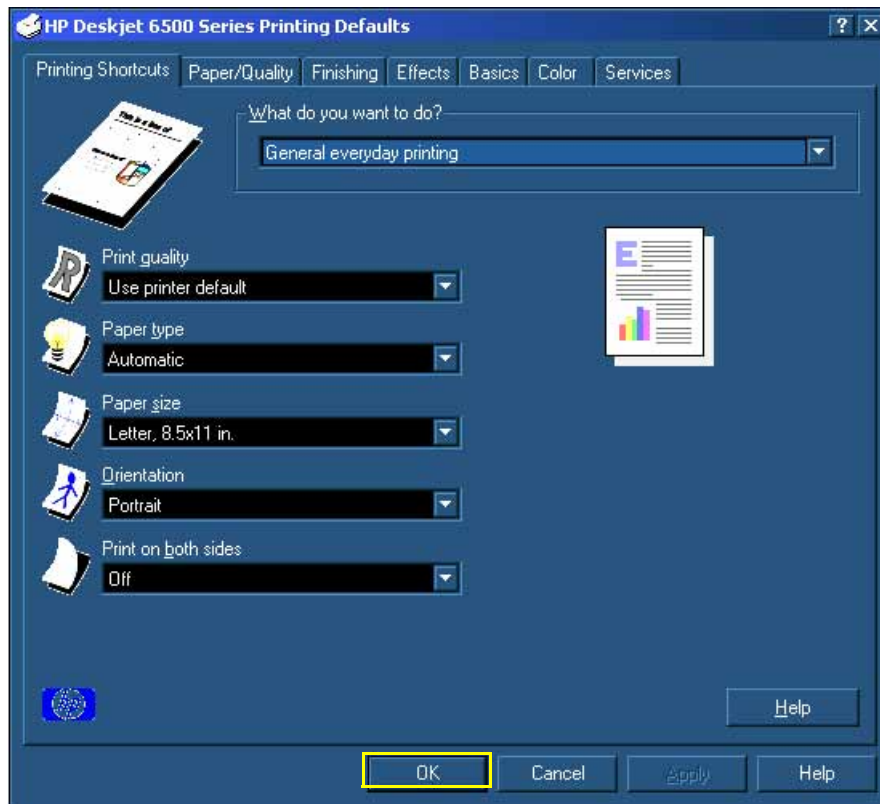

Figure 8-194 Printing Defaults Dialog Box

26.) Set up the printing defaults (Paper size, Paper type etc....) to your liking, then click **OK**.

The following message is displayed:

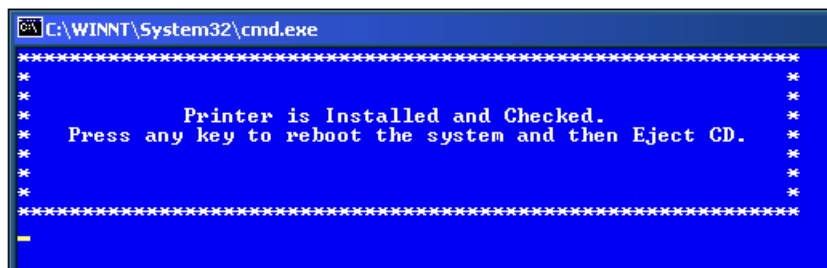

Figure 8-195 Printer Installed and Checked Message

27.) Press any key to reboot the system and then eject the CD from the CD tray.

28.) Press the **Config** button on control console and from the System Configuration window, activate the Printers tab - see Figure 8-196.

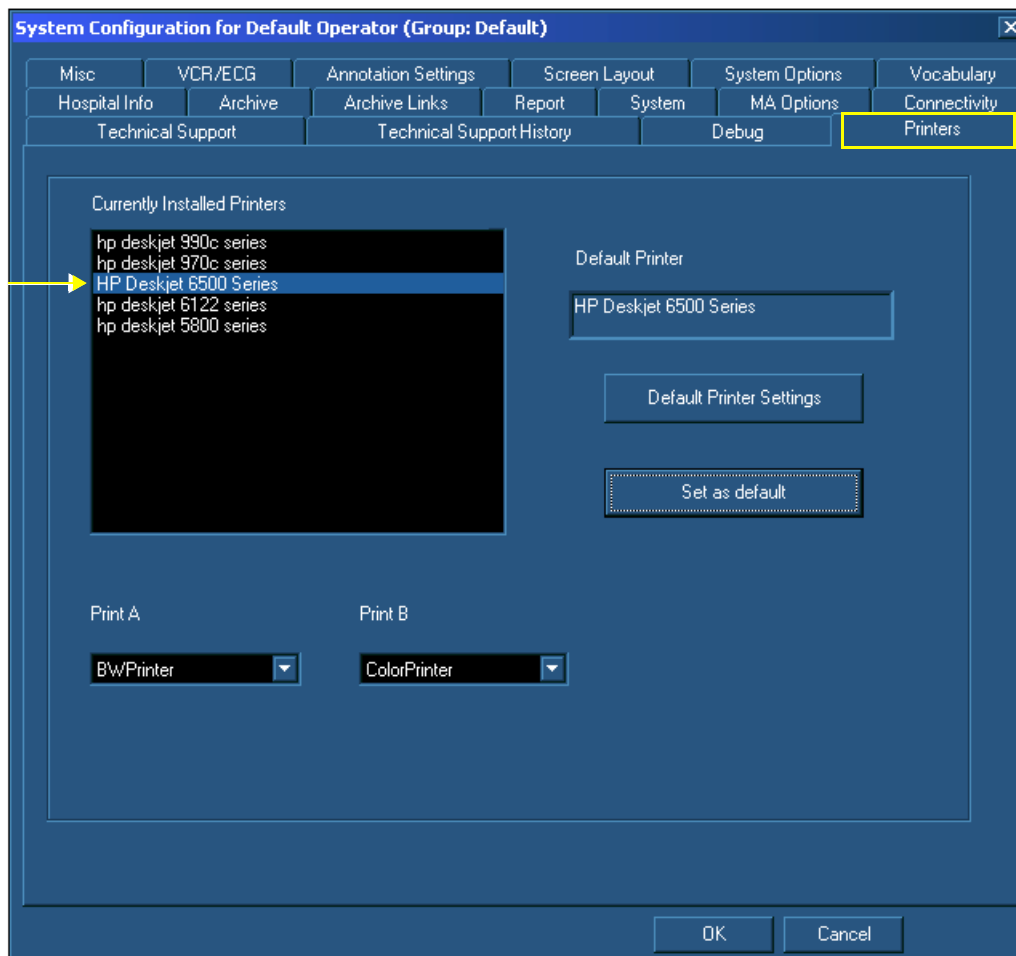

Figure 8-196 System Configuration Window - Printers Tab

29.) Confirm that **HP Deskjet 6500 Series** has been added to *Currently Installed Printers* list, then click **OK**.

8-8-8-5 HP 6540/3 USB Deskjet Color Printer Removal Procedure

- 1) Turn OFF power to the USB printer.
- 2) Unplug the AC power cable from the Power IN socket at the rear of the printer.
- 3) Unplug the USB cable from the USB socket at the rear of the printer.
- 4) Remove the USB printer.

8-8-8-6 HP 5652 Deskjet Color Printer Installation Procedure - Vivid 3 BT00 Systems

NOTE: Since Vivid3 BT00 systems are based on the Windows NT operating system, they do not support the Plug & Play feature. Therefore, the HP990c driver (already installed on the system) can also be used for the HP 5652 Deskjet Color Printer, without requiring the installation of any additional printer drivers. All that is necessary is to set the HP990c as the default printer, as described in the procedure below.

- 1.) Place the HP 5652 Deskjet Color Printer on the Vivid 3 bottom shelf allowing sufficient room to access the cables at the rear of the printer, or on a stable surface located not far from the Vivid 3 scanner.
- 2.) Connect one end of the Printer power cable to the Vivid 3 rear connectors panel and the other end (via the transformer [supplied]) to the Low Voltage Power-IN socket on the rear of the printer, as shown in [Figure 8-178](#) below.

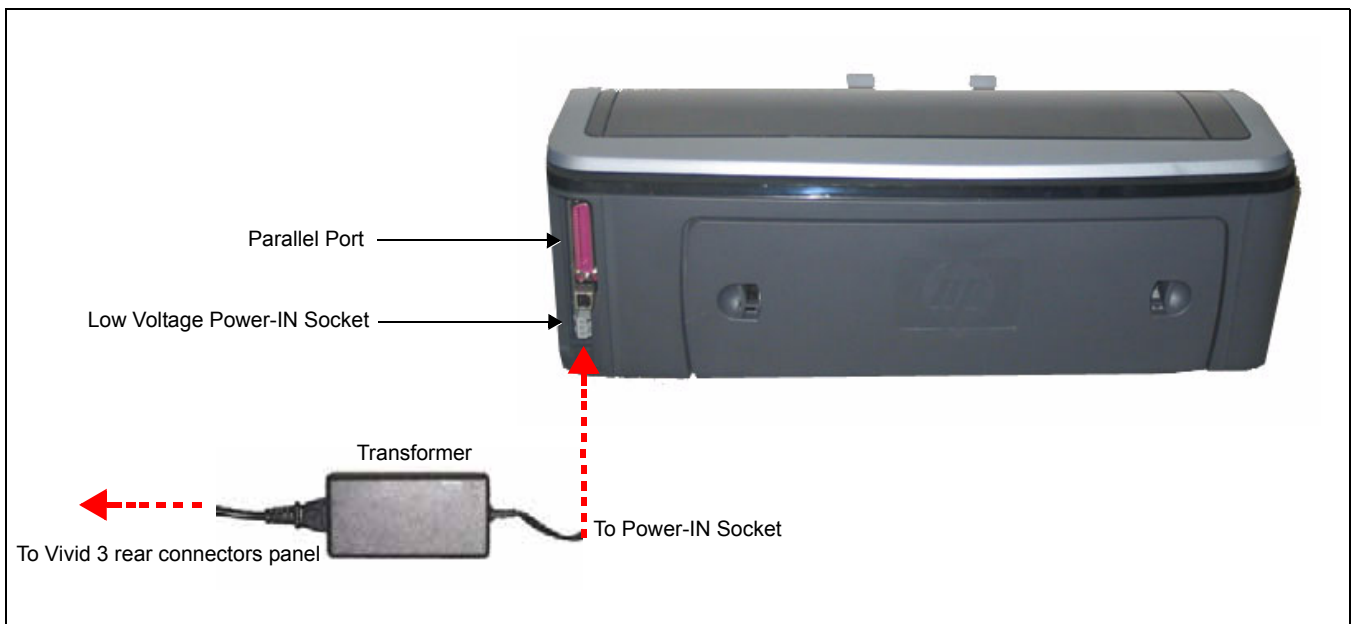

Figure 8-197 HP 5652 Deskjet Color Printer- Rear View



WARNING: To avoid electrical hazards , the 5652 HP Deskjet Color Printer must be connected to the AC Supply of the Vivid™ 3 Ultrasound Unit and never directly to the local AC wall outlet.

- 3.) Turn ON power to the system and the printer and boot up the system in *User* mode.

- 4.) Press the **Config** button on the control console, then from the System Configuration window, activate the **System** tab (Figure 8-198).

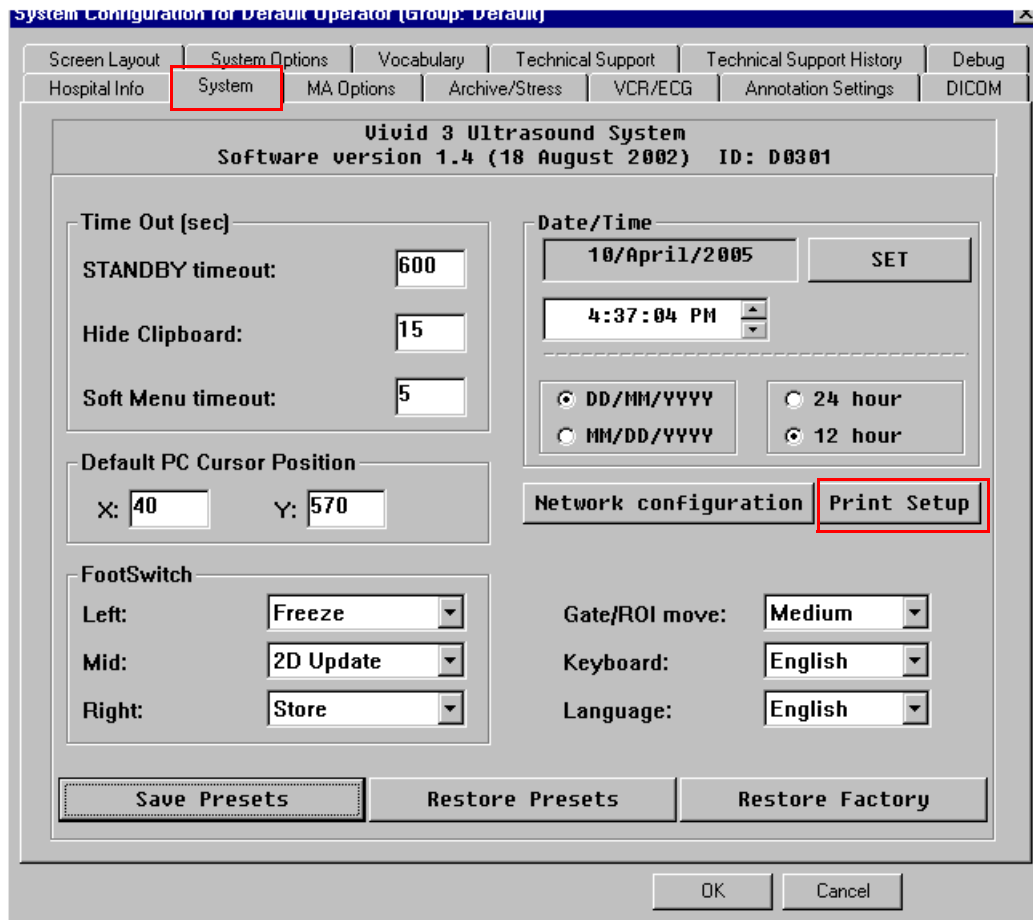

Figure 8-198 System Configuration Window - System Tab

- 5.) Click on the **Print Setup** button.
The following window opens, listing the currently-installed printers:

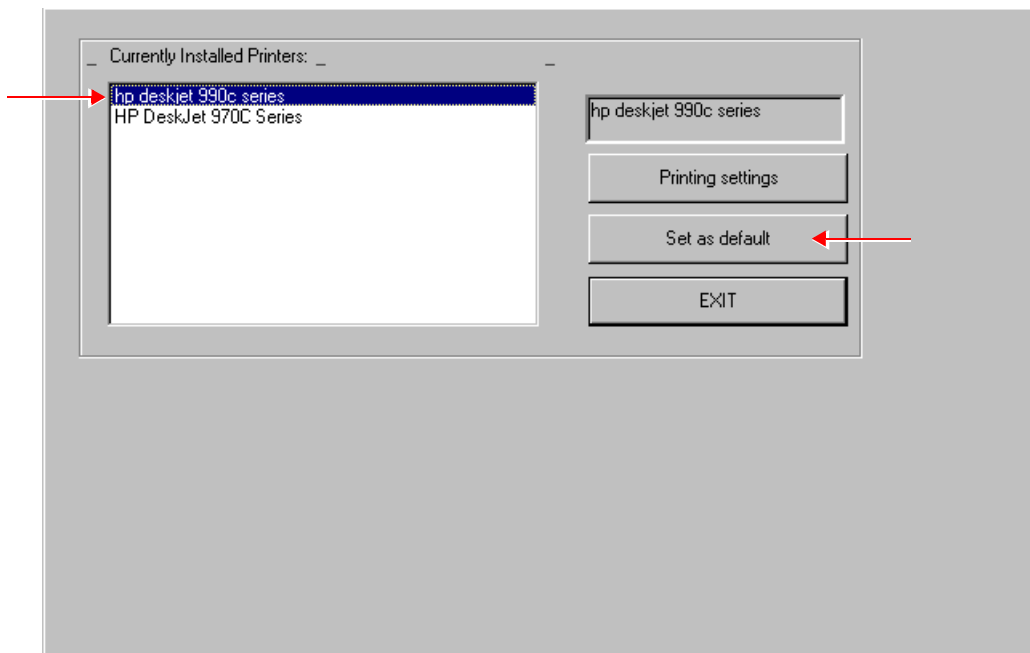

Figure 8-199 Currently Installed Printers Window

- 6.) Highlight *hp deskjet 990c series* as shown above, then click on the **Set as default** button.
- 7.) Click on the **Printing settings** button to access the Printer Properties dialog box:

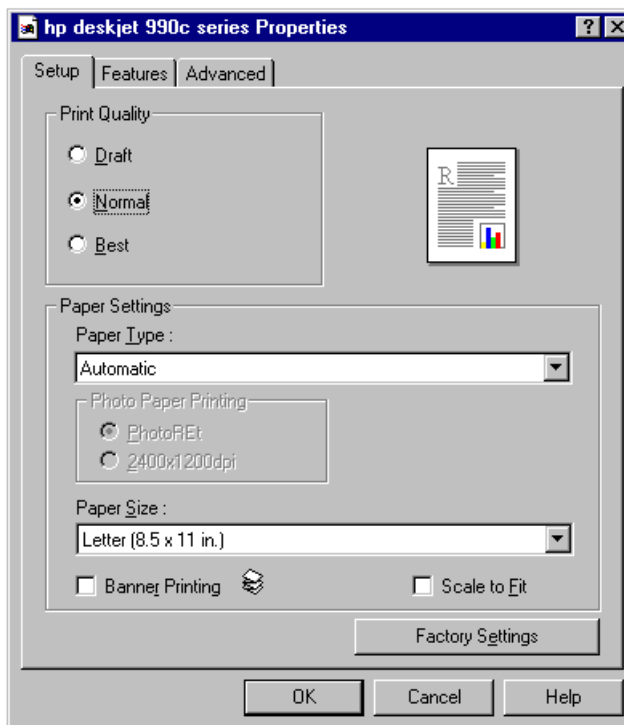

Figure 8-200 Printer Properties Dialog Box

- 8.) Set up the printing defaults (Paper size, Paper type *etc....*) to your liking, then click **OK**.
The System Configuration window is re-displayed (refer to [Figure 8-198](#) on page 8-188).
- 9.) Click **OK** to close the window.

8-8-8-7 HP 5652 Deskjet Color Printer Removal Procedure - Vivid 3 BT00 Systems

- 1) Turn OFF power to the HP 5652 printer.
- 2) Unplug the AC power cable from the Power IN socket at the rear of the printer.
- 3) Unplug the parallel cable from the parallel port at the rear of the printer.
- 4) Remove the HP 5652 printer.

Chapter 9

Renewal Parts

Section 9-1 Overview

9-1-1 Purpose of Chapter 9

This chapter gives you an overview of replacement parts for the Vivid™ 3 ultrasound unit.

Table 9-1 Contents in Chapter 9

Section	Description	Page Number
9-1	Overview	9-1
9-2	List of Abbreviations	9-2
9-3	Renewal Parts Lists and Diagrams	9-3
9-4	Peripherals	9-35
9-5	Cabling Block Diagrams	9-36

Section 9-2 List of Abbreviations

- **Assy** - Assembly
- **BEP** - Back End Processor
- **Ctrl** - Control
- **FEP** - Front End Processor
- **FRU 1** - Replacement part available in parts hub
- **FRU 2** - Replacement part available from the manufacturer (lead time involved)
- **LCD** - Liquid Crystal Display
- **Int** - Internal
- **I/O** - Input/Output
- **PWA** - Printed Wire Assembly
- **Recv** - Receive
- **XFRMR** - Transformer

Section 9-3 Renewal Parts Lists and Diagrams

9-3-1 Mechanical Hardware Parts

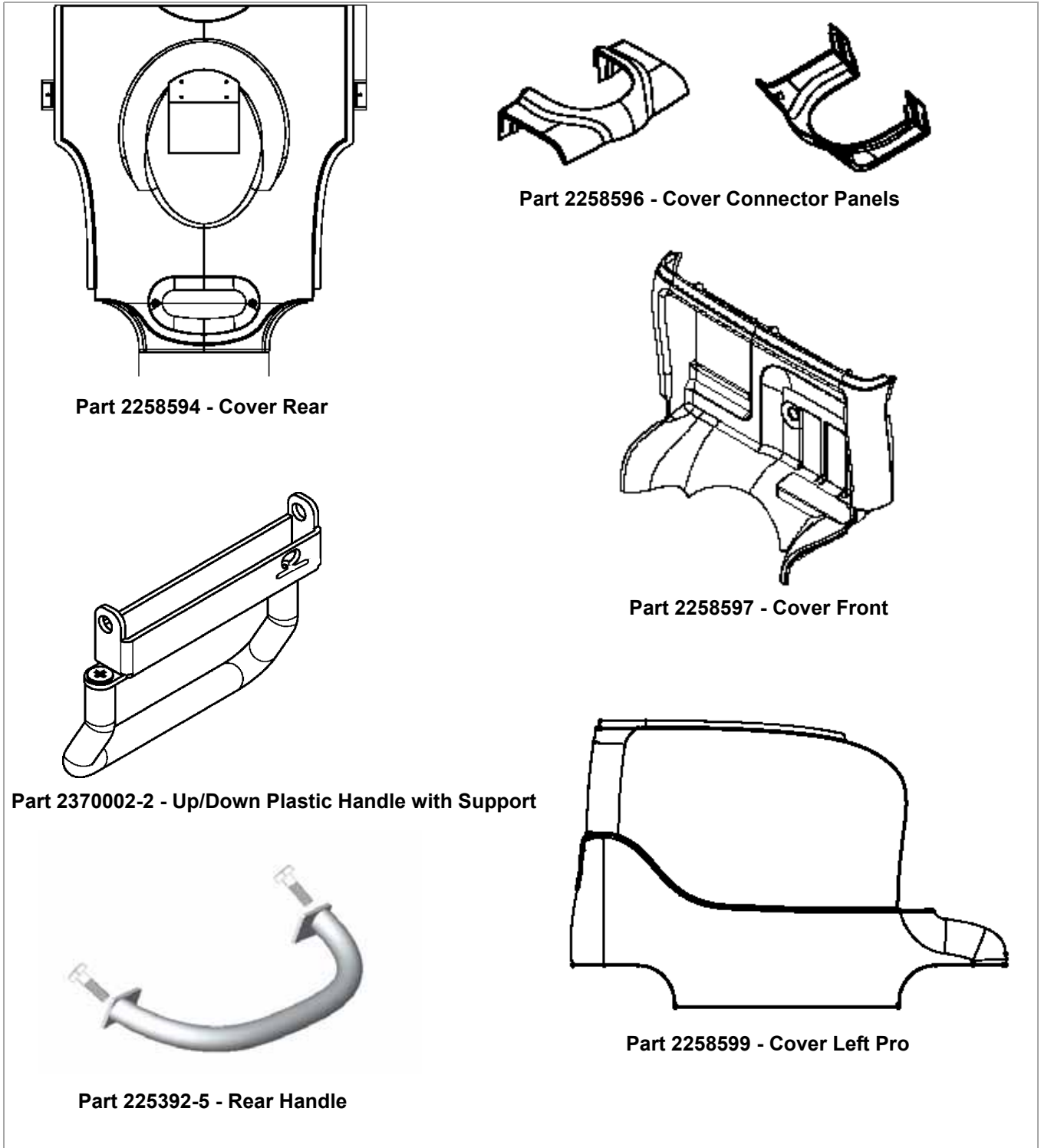
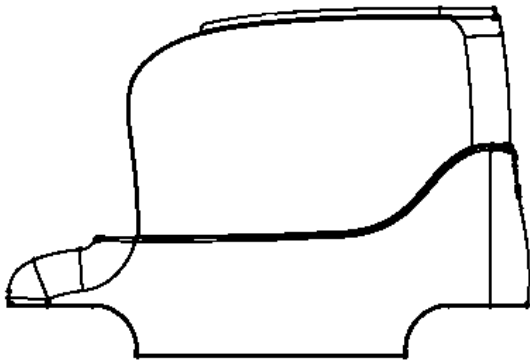
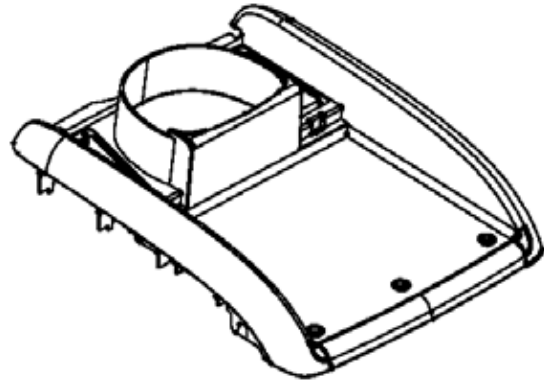

Figure 9-1 Mechanical Hardware Parts - Diagram 1



Part 2258600 - Cover Right Pro



Part 2258602 - Cover Top (Lower Section)

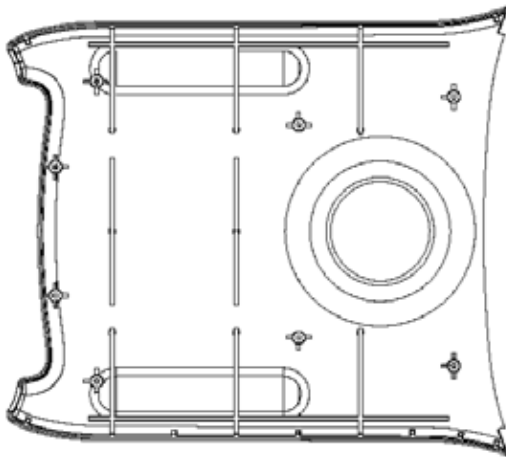

Part 2261572 - Cover Top (Upper Section)

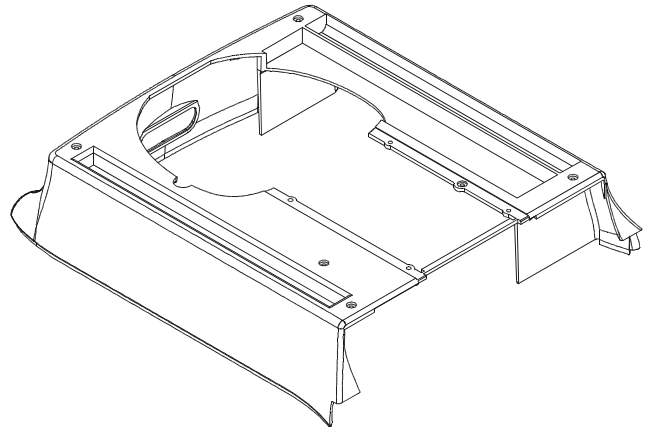

Part 2261573 - Cover Bottom Rear (Upper Section)

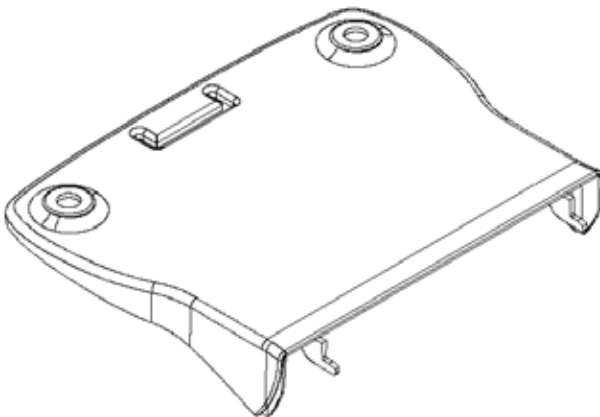

Part 2261574 - Cover Bottom Front (Upper Section)

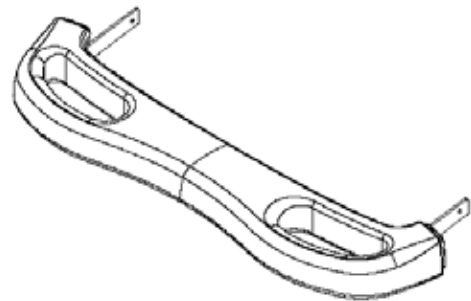

Part 2261578 - Front Handle

Figure 9-2 Mechanical Hardware Parts - Diagram 2

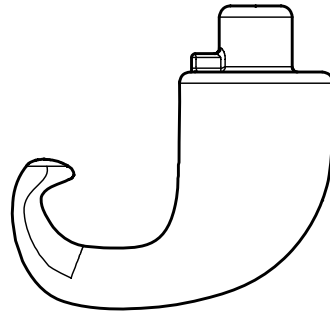

Part 2263841 - Probe Cable Holder

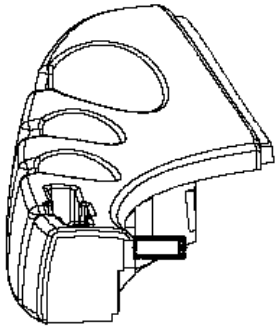

Part 2261576 - Probe Holder Left

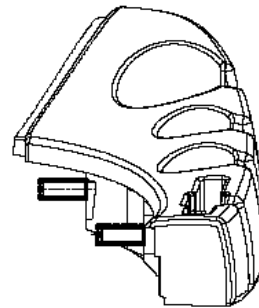

Part 2261577 - Probe Holder Right

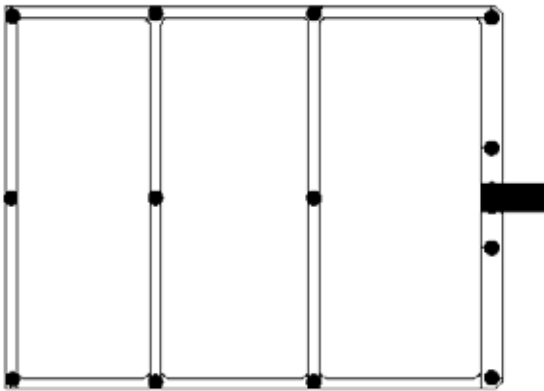

Part 2301690 - Filter (Air)

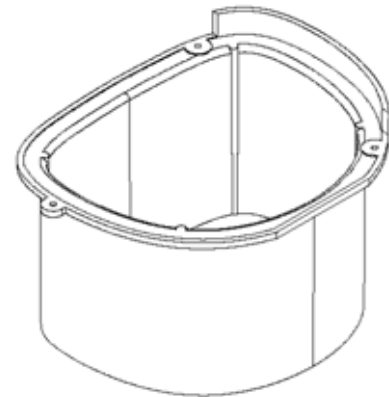

Part 2261575 - Cover Gas Spring



Part 2276027 - Gas Spring Assembly

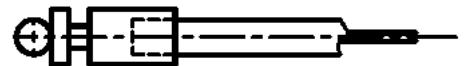

Part 2268877 - Gas Spring Cable

Figure 9-3 Mechanical Hardware Parts - Diagram 3



Part 2389102 - Caster Wheel (Rear)



Part 2392789 - Caster Wheel (Front) with brake



Part 2293820 - Cover Speakers with GE logo

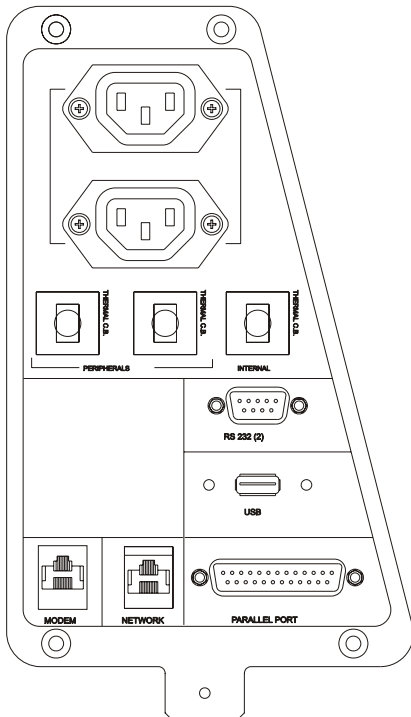

Part 2253013 - Rear Connector Panel *Right*



Part 264C0001 - Cable Clip

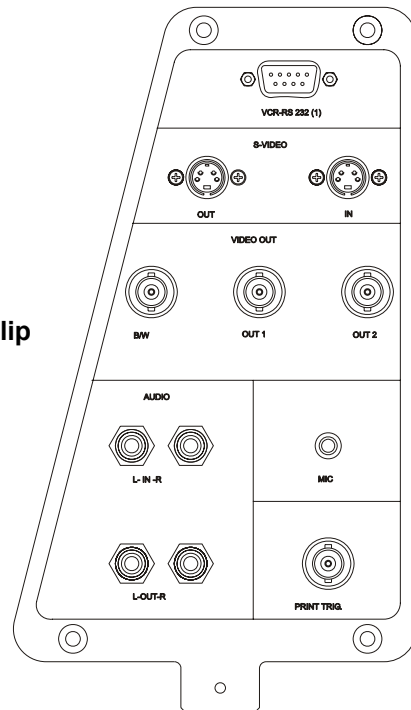

Part 2253008 - Rear Connector Panel *Left*

Figure 9-4 Mechanical Hardware Parts - Diagram 4

Table 9-2 Mechanical Hardware Parts

P/N	Part Name	FRU	Pro BT03	BT03	Refer to
2258594	Cover Rear	2	✓	✓	Figure 9-1 on page 9-3
2258596	Cover Connector Panels	2	✓	✓	Figure 9-1 on page 9-3
2258597	Cover Front	2	✓	✓	Figure 9-1 on page 9-3
2258599	Cover Left	1	✓	✓	Figure 9-1 on page 9-3
2258600	Cover Right	1	✓	✓	Figure 9-2 on page 9-4
2258602	Cover Top (Lower Section)	2	✓	✓	Figure 9-2 on page 9-4
2261572	Cover Top (Upper Section)	2	✓	✓	Figure 9-2 on page 9-4
2370002-2	Up/Down Handle (plastic, with support)	2	✓	✓	Figure 9-1 on page 9-3
225392-5	Rear Handle	2	✓	✓	Figure 9-1 on page 9-3
2261573	Cover Bottom Rear (Upper Section)	2	✓	✓	Figure 9-2 on page 9-4
2261574	Cover Bottom Front (Upper Section)	1	✓	✓	Figure 9-2 on page 9-4
2261575	Cover Gas Spring/Sleeve	2	✓	✓	Figure 9-3 on page 9-5
2261576	Probe Holder Left	2	✓	✓	Figure 9-3 on page 9-5
2261577	Probe Holder Right	2	✓	✓	Figure 9-3 on page 9-5
2261578	Front Handle	2	✓	✓	Figure 9-2 on page 9-4
2263841	Probe Cable Holder	2	✓	✓	Figure 9-3 on page 9-5
2276027	Gas Spring Assembly	2	✓	✓	Figure 9-3 on page 9-5
2268877	Gas Spring Cable	2	✓	✓	Figure 9-3 on page 9-5
2301690	Filter (Air)	2	✓	✓	Figure 9-3 on page 9-5
2389102	Wheel (Castor) - Rear	1	✓	✓	Figure 9-4 on page 9-6
2392789	Wheel (Castor) - Front (with brake)	1	✓	✓	Figure 9-4 on page 9-6
2293820	Cover Speakers with GE Logo	2	✓	✓	Figure 9-4 on page 9-6

Table 9-2 Mechanical Hardware Parts

P/N	Part Name	FRU	Pro BT03	BT03	Refer to
2253013	Rear Connector Panel Right (with cables)	2	✓	✓	Figure 9-4 on page 9-6
2253008	Rear Connector Panel Left (with cables)	2	✓	✓	Figure 9-4 on page 9-6
264C0001	Cable Clip	2	✓	✓	Figure 9-4 on page 9-6
2253052	Screw Kit	1	✓	✓	
2394000	Keycap Kit	1	✓	✓	

9-3-2 AC System Parts



Part 2252994 - Input AC Box and Circuit Breaker



Part 2399304 - AC Voltage Distribution Box



Part 2253054 - Connector AC Voltage Primary 100-120V



Part 2253056 - Connector AC Voltage Primary 200-240V



Part 2253057 - Connector AC Voltage Secondary 100V



Part 2253058 - Connector AC Voltage Secondary 120V



Part 2253059 - Connector AC Voltage Secondary 220V



Part 2253060-2 - Connector AC Voltage Secondary 220-240V

Figure 9-5 AC System Parts

Table 9-4 AC System Parts

P/N	Part Name	FRU	Pro BT03	BT03	Refer to
2252994	Input AC Box and Circuit Breaker	1	✓	✓	Figure 9-5 on page 9-9
2399304	AC Voltage Distribution Box	1	✓	✓	Figure 9-5 on page 9-9
2253054	Connector AC Voltage Primary 100-120V	2	✓	✓	Figure 9-5 on page 9-9
2253056	Connector AC Voltage Primary 200-240V	2	✓	✓	Figure 9-5 on page 9-9
2253057	Connector AC Voltage Secondary 100V	2	✓	✓	Figure 9-5 on page 9-9
2253058	Connector AC Voltage Secondary 120V	2	✓	✓	Figure 9-5 on page 9-9
2253059	Connector AC Voltage Secondary 220V	2	✓	✓	Figure 9-5 on page 9-9
2253060-2	Connector AC Voltage Secondary 220-240V	2	✓	✓	Figure 9-5 on page 9-9

9-3-3 Front End Parts



Part 2270068 - Low Voltage Power Supply



Part 2295971 - FAN 92x92 Crate Fan 12V



Part 2253030-3 - Front End Crate (RFI models only)



Part 2253030-2 - Front End Crate (including back plan MB)

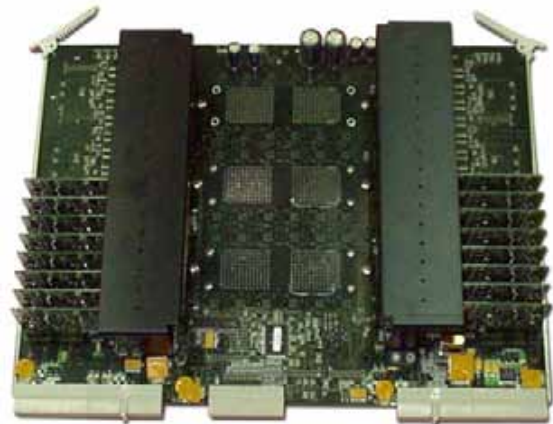

Part 2253033-2 - PCB Front Board and TR4 Assembly (FB, 2Con.,V7)

Figure 9-6 Front End Parts - Diagram 1

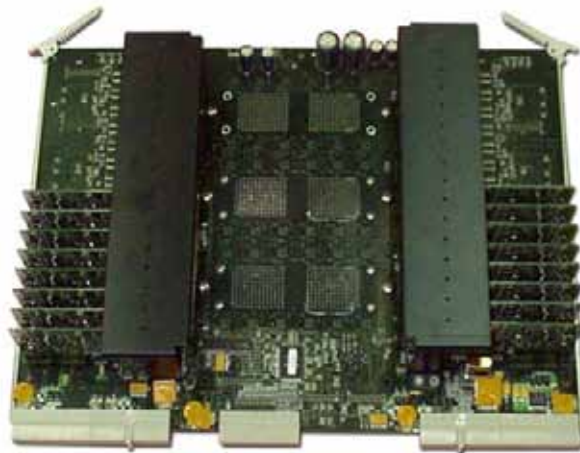

Part 2253033-3 - PCB Front Board and TR4 Assembly (FB, 3Con.,V7)



Part 2418129 - PCB TR4 Board

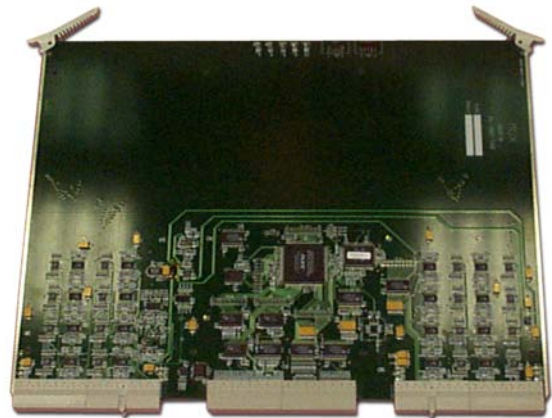

Part 2253038-3 - PCB Multiplexer (MUX)

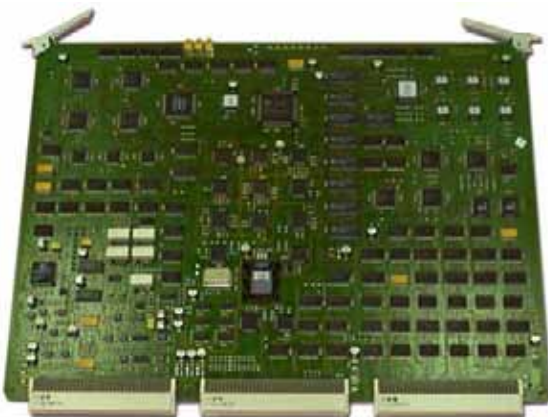

Part FA200764 - PCB Front End Controller



Part FA200114 - Tx Voltage Power Supply (TXPS), HV Power Supply

Figure 9-7 Front End Parts - Diagram 2

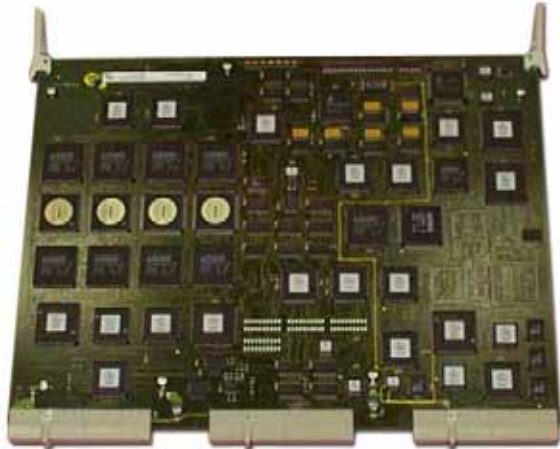

Part FB200992 - PCB RF Tissue (RFT, MLA2)

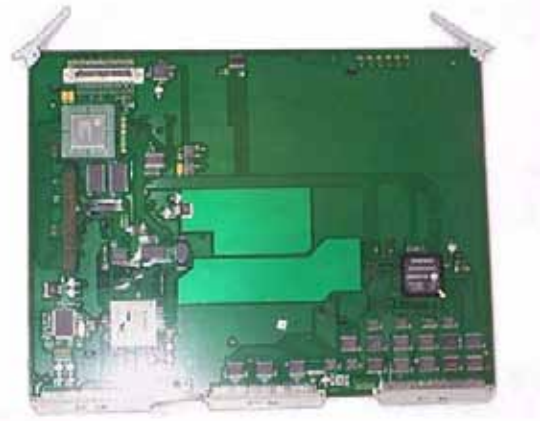

Part FC200120 - PCB Image Port 3 (IMP3)

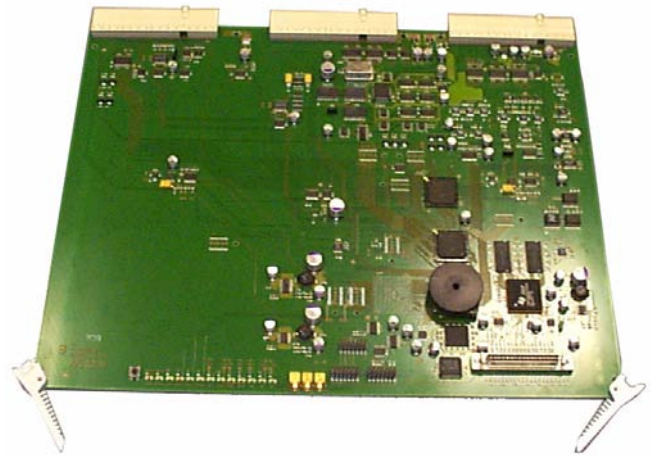

Part FC200507 - PCB RFI (IMP, RFT, & FEC)

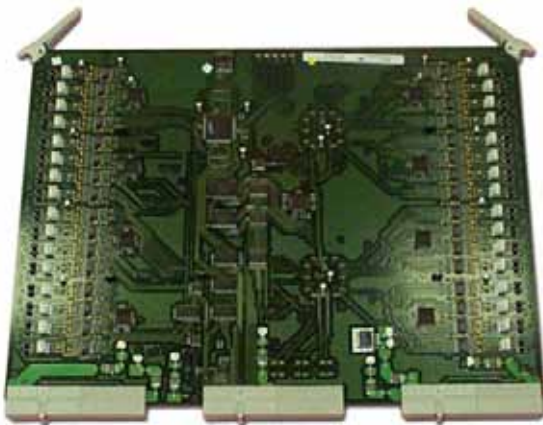

Part FB200900 - PCB Beamformer (BF) 64ch

Figure 9-8 Front End Parts - Diagram 3

Table 9-6 Front End Parts

P/N	Part Name	FRU	Pro BT03	BT03	Refer to
2253030-2	Front End Crate (including back plan MB)	2	✓	✓	Figure 9-6 on page 9-11
2253030-3	Front End Crate	2	a	a	Figure 9-6 on page 9-11
2253033-2	PCB: Front Board and TR4 Assembly (FB, 2Con.,V7)	1	✓	✓	Figure 9-6 on page 9-11
2253033-3	PCB: Front Board and TR4 Assembly (FB, 3Con.,V7)	1	✓	✓	Figure 9-7 on page 9-12
2418129	PCB: TR4 Board	1	✓	✓	Figure 9-7 on page 9-12
2253038-3	PCB Multiplexer (MUX)	1	✓	✓	Figure 9-7 on page 9-12
2295971	FAN 92x92 Crate Fan 12V	1	✓	✓	Figure 9-6 on page 9-11
2270068	Low Voltage Power Supply (LVPS)	1	✓	✓	Figure 9-6 on page 9-11
FA200114	TX Voltage Power Supply (TXPS), HV Power Supply	1	✓	✓	Figure 9-7 on page 9-12
FC200507	PCB Radio Frequency Interface (RFI)	1	a	a	Figure 9-8 on page 9-13
FB200992	PCB RF Tissue (RFT, MLA2)	1	✓	✓	Figure 9-8 on page 9-13
FA200764	PCB Front End Controller (FEC)	1	✓	✓	Figure 9-7 on page 9-12
FB200900	PCB Beamformer (BF) 64ch	1	✓	✓	Figure 9-8 on page 9-13
FC200120	PCB Image Port 3 (IP3)	1	✓	✓	Figure 9-8 on page 9-13

a. Applicable to RFI-configured systems *only*

9-3-4 Back End Parts



Part 2253043 Keyboard Matrix Assembly English



Part 2274623 Keyboard Trackball



Part 2256476 ECG Box Assembly (Patient I/O Module)

Figure 9-12 Back End Parts - Diagram 1



Part 2315842-7 BEP Basic



Part 2316279 PCB Plug & Scan Card



Part 2346011 BEP2 Power Supply



Part 2300858 Plug & Scan Battery



Part 2277189 MO Drive 5.25



Part 2399676 - Frame Grabber

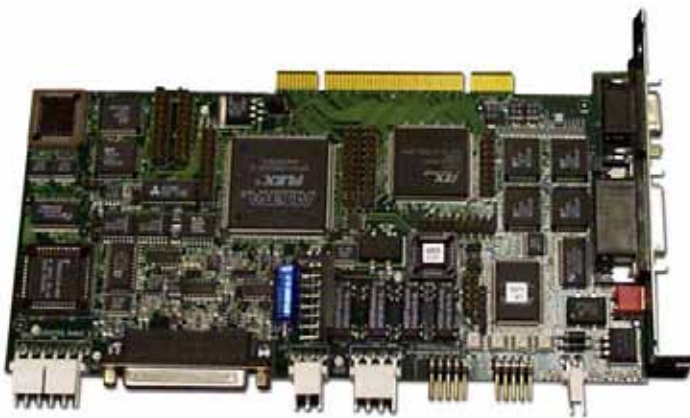

Part 2253027-5 PCB Keyboard Control Card



Part 066E0007 Footswitch

Figure 9-13 Back End Parts - Diagram 2



Part 2336022-2 Samsung 15" Monitor (591-S) for Pro



Part 2306835-6 Monitor for Expert 17"

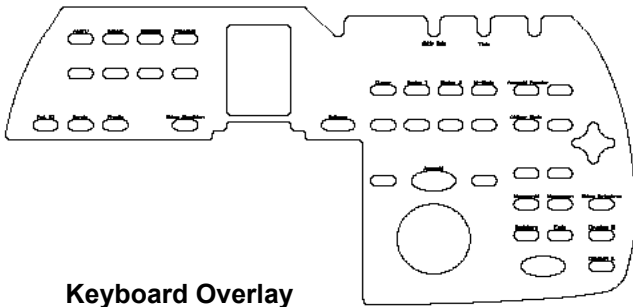

Keyboard Overlay

(see [Table 9-8](#) on [page 9-19](#) for Part Numbers and Languages)



Part EP200132 Isolation Box (network)



Part 2269309 Speakers (pair)

Figure 9-14 Back End Parts - Diagram 3



Part 2408479 Hard Disk Drive (HDD)



Part 2346034 Floppy Drive



Part 2413449 CD Drive RW



Part 2271149-2 PCB SCSI Card



Part 2340279 PC Video Encoder Control Assembly (PC-VIC)



Part FC200656 PC2IP2 Card



Part FB200973 PCB PC2IP Card

Figure 9-15 Back End Part - Diagram 4

Table 9-8 Back End Parts

P/N	Part Name	FRU	Pro BT03	BT03	Refer to
2340279	PC Video Encoder Control Assembly (PC-VIC)	1	✓	✓	Figure 9-15 on page 9-18
2256476	ECG Box Assembly (Patient I/O Module)	1	✓	✓	Figure 9-12 on page 9-15
2336022-2	Monitor 15" with Base	1	✓	✓	Figure 9-14 on page 9-17
2306835-6	Monitor 17" with Base	1	a	a	Figure 9-14 on page 9-17
2408479	Hard Disk Drive (HDD)	1	✓	✓	Figure 9-15 on page 9-18
2346034	Floppy Drive	2	✓	✓	Figure 9-15 on page 9-18
2413449	CD Drive RW	1	✓	✓	Figure 9-15 on page 9-18
2300858	Plug & Scan Battery	1	b	b	Figure 9-13 on page 9-16
2316279	PCB Plug & Scan Card	1	b	b	Figure 9-13 on page 9-16
2271149-2	PCB SCSI Card	1	c	c	Figure 9-15 on page 9-18
2277189	MO Drive 5.25	1	c	c	Figure 9-13 on page 9-16
066E0007	Footswitch	2	✓	✓	Figure 9-13 on page 9-16
2269309	Speakers (pair)	2	✓	✓	Figure 9-14 on page 9-17
2274623	Keyboard Trackball	1	✓	✓	Figure 9-12 on page 9-15
2253043	Keyboard Matrix Assembly English	1	✓	✓	Figure 9-12 on page 9-15
2393953-2	Keyboard Overlay - German	2	✓	✓	Figure 9-14 on page 9-17
2393953-3	Keyboard Overlay Assembly - French	2	✓	✓	Figure 9-14 on page 9-17
2393953-4	Keyboard Overlay Assembly - Spanish	2	✓	✓	Figure 9-14 on page 9-17
2393953-5	Keyboard Overlay Assembly - Portuguese	2	✓	✓	Figure 9-14 on page 9-17
2393953-6	Keyboard Overlay Assembly - Italian	2	✓	✓	Figure 9-14 on page 9-17
2393953-8	Keyboard Overlay Assembly - Russian	2	✓	✓	Figure 9-14 on page 9-17
2393953-10	Keyboard Overlay Assembly - Danish	2	✓	✓	Figure 9-14 on page 9-17
2393953-11	Keyboard Overlay Assembly - Norwegian	2	✓	✓	Figure 9-14 on page 9-17
2393953-12	Keyboard Overlay Assembly - Swedish	2	✓	✓	Figure 9-14 on page 9-17
2393953-13	Keyboard Overlay Assembly - Finnish	2	✓	✓	Figure 9-14 on page 9-17
2393953-14	Keyboard Overlay Assembly - Dutch	2	✓	✓	Figure 9-14 on page 9-17

Table 9-8 Back End Parts (Continued)

P/N	Part Name	FRU	Pro BT03	BT03	Refer to
2393953-15	Keyboard Overlay Assembly - Greek	2	✓	✓	Figure 9-14 on page 9-17
2315842-7	BEP Vivid™ 3 Assy Basic	1	d	d	Figure 9-13 on page 9-16
2346011	BEP2 Power Supply	1	✓	✓	Figure 9-13 on page 9-16
EP200132	Isolation Box (network)	N	✓	✓	Figure 9-14 on page 9-17
2399676	Frame Grabber	1	e	e	Figure 9-13 on page 9-16
2253027-5	PCB Keyboard Control Card	1	✓	✓	Figure 9-13 on page 9-16
FC200656	PCB PC2IP2 Card	1	e	e	Figure 9-15 on page 9-18
FB200973	PCB PC2IP Card	1	✓	✓	Figure 9-15 on page 9-18

- a. This is an option that should be ordered via Cat# H45011MK.
- b. This hardware is an option that should be ordered via Cat# H45011AT.
- c. This hardware is an option that should be ordered via Cat# H45011CF.
- d. Note: Before ordering the new BEP, review to the [Back End Processor Replacement Procedure](#) on page 8 - 58 and check for any additional BEP components required as shown in [Table 8-3](#) on page 8-55.
- e. Applicable to RFI-configured systems *only*.

9-3-5 Cables

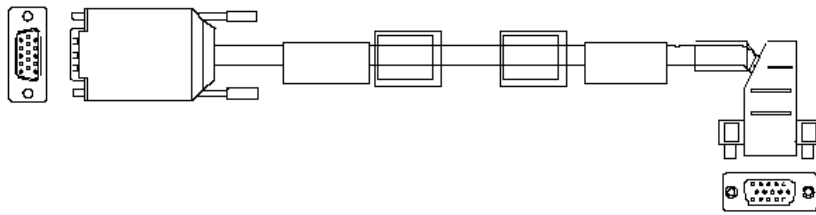

Part 2252964 VGA Out



Part 2371429 YC to Frame Grabber

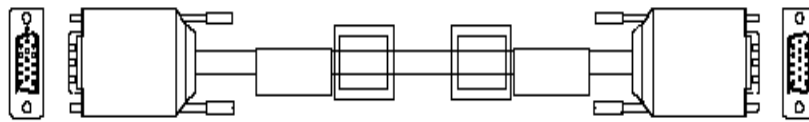

Part 2252965 VGA VIC/ PC

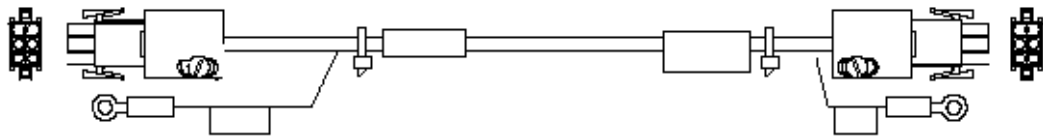

Part 2252966 Input Box / AC Distribution Box

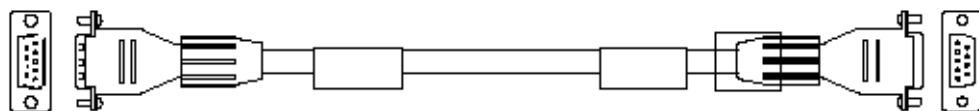

Part 2252967 - Soft Shutdown



Part 2252968 Ground VIC



Part 2252969 - Ground / Back End

Figure 9-21 Cables - Diagram 1

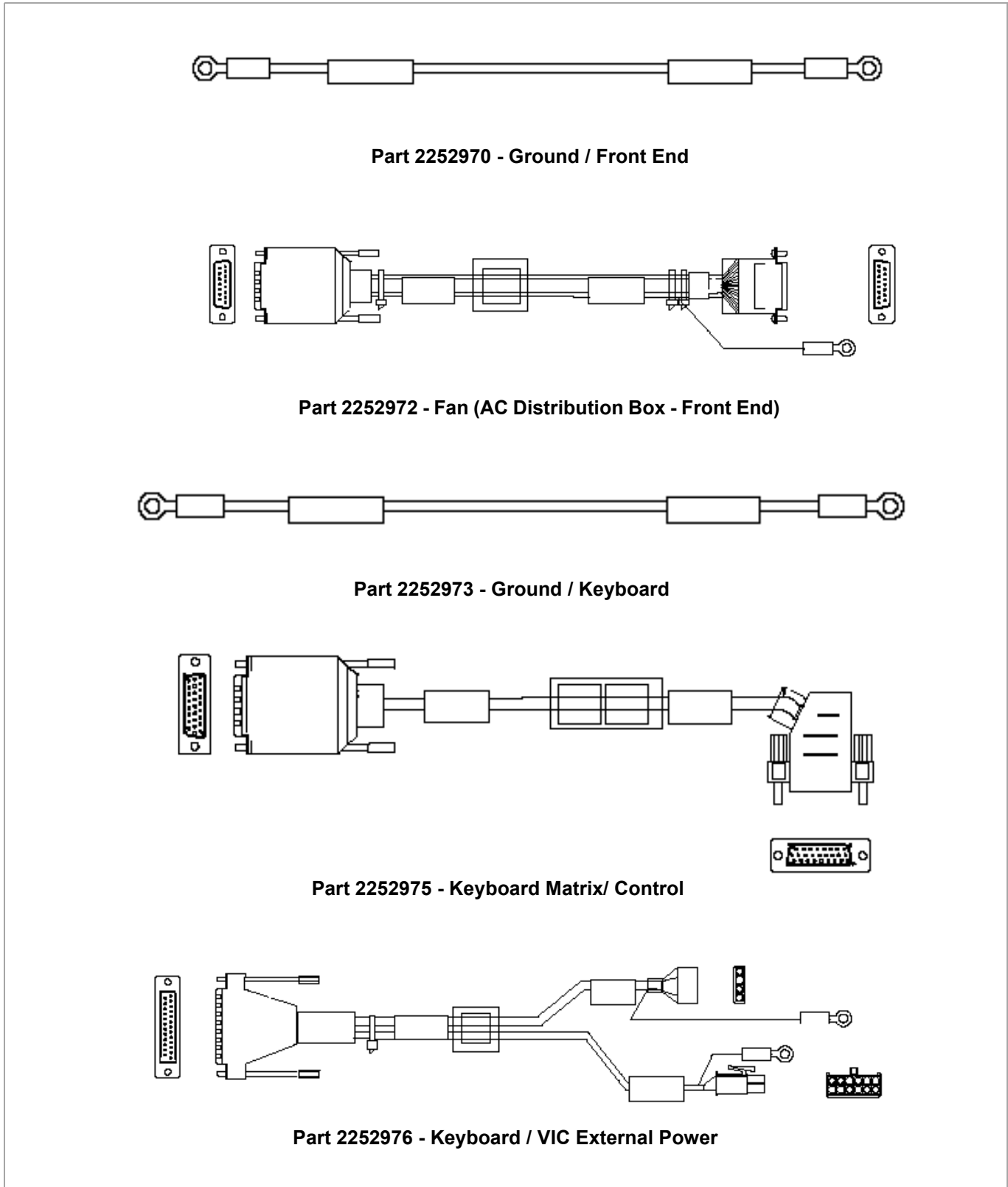

Figure 9-22 Cables - Diagram 2

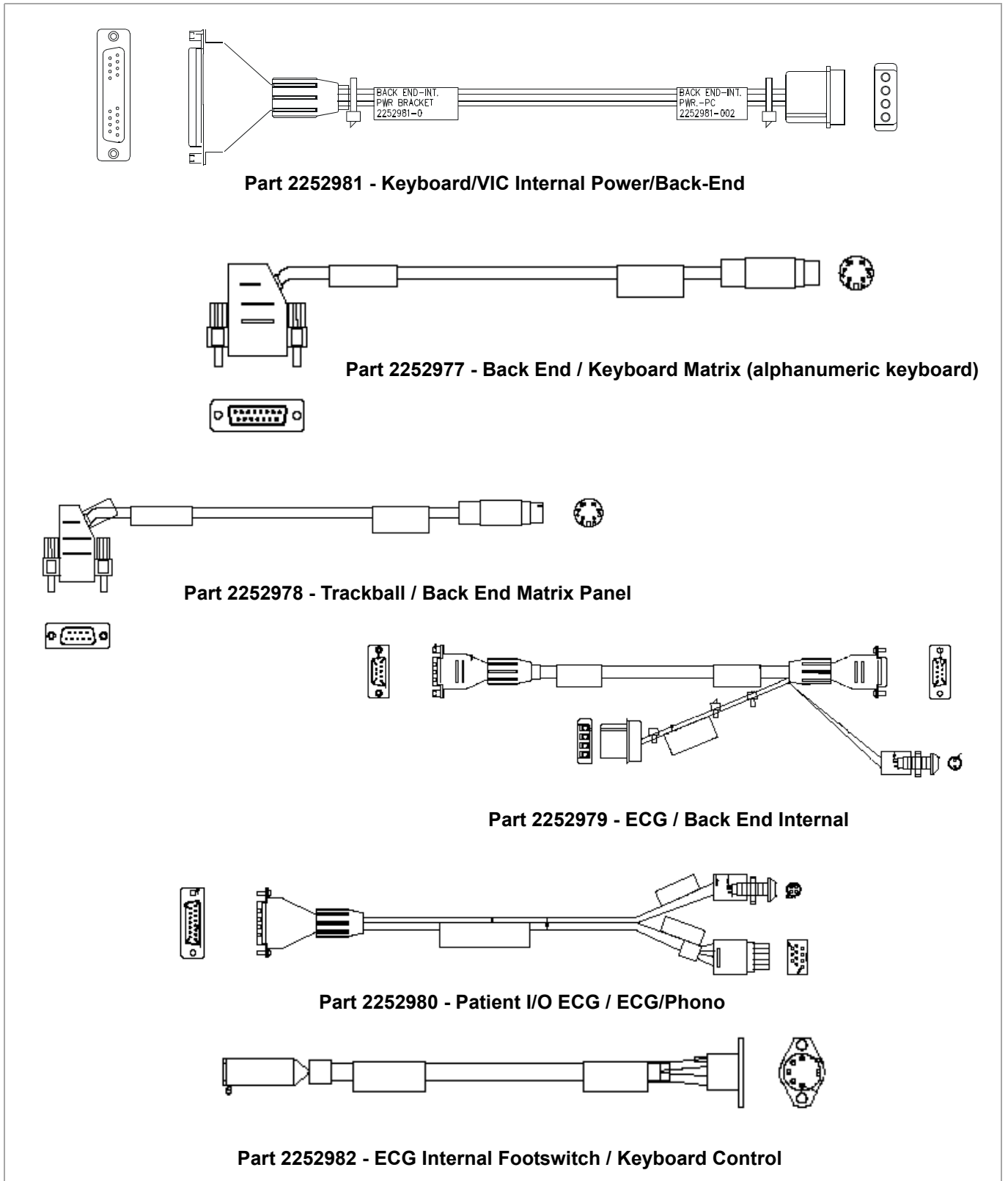

Figure 9-23 Cables - Diagram 3

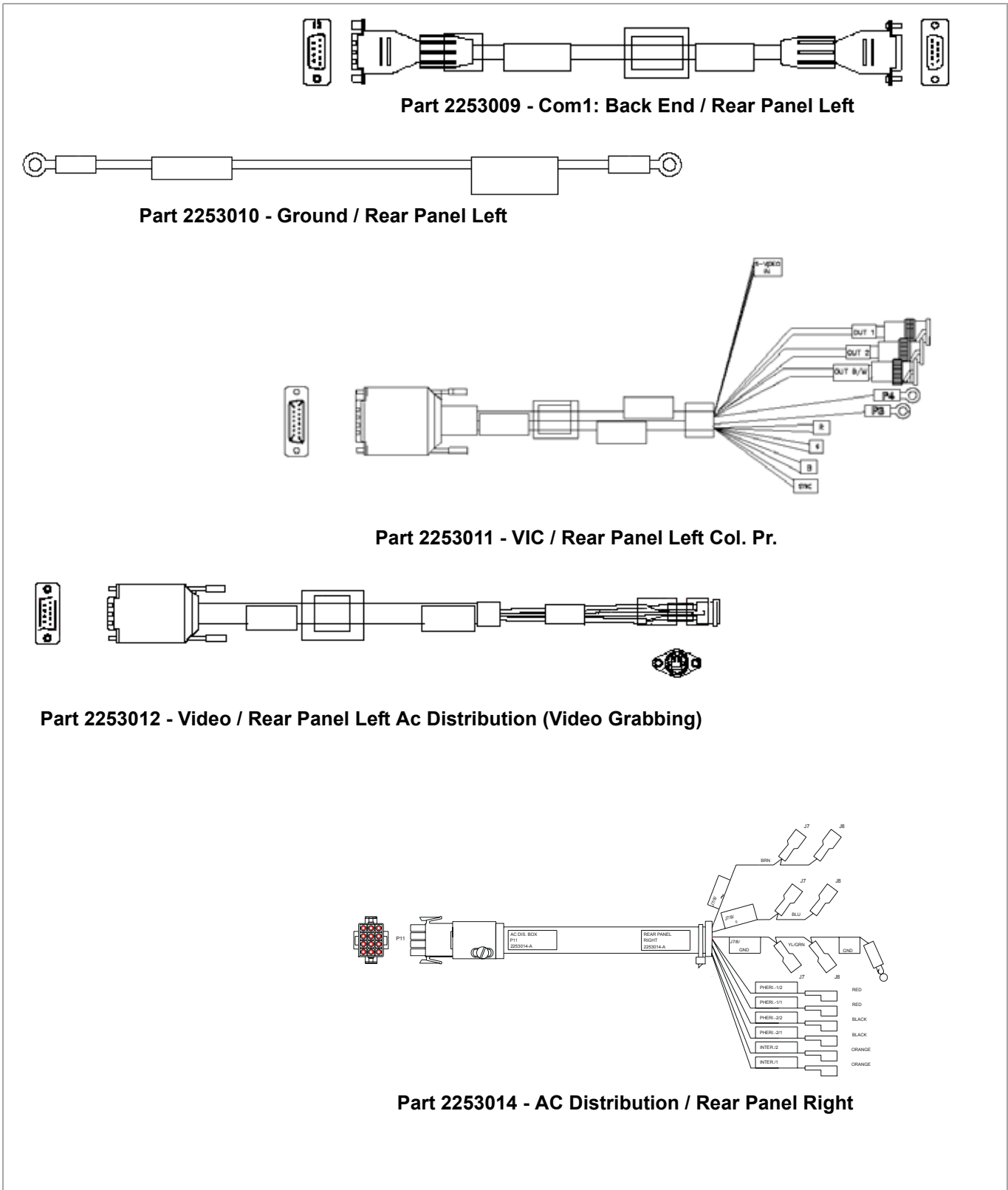

Figure 9-24 Cables - Diagram 4

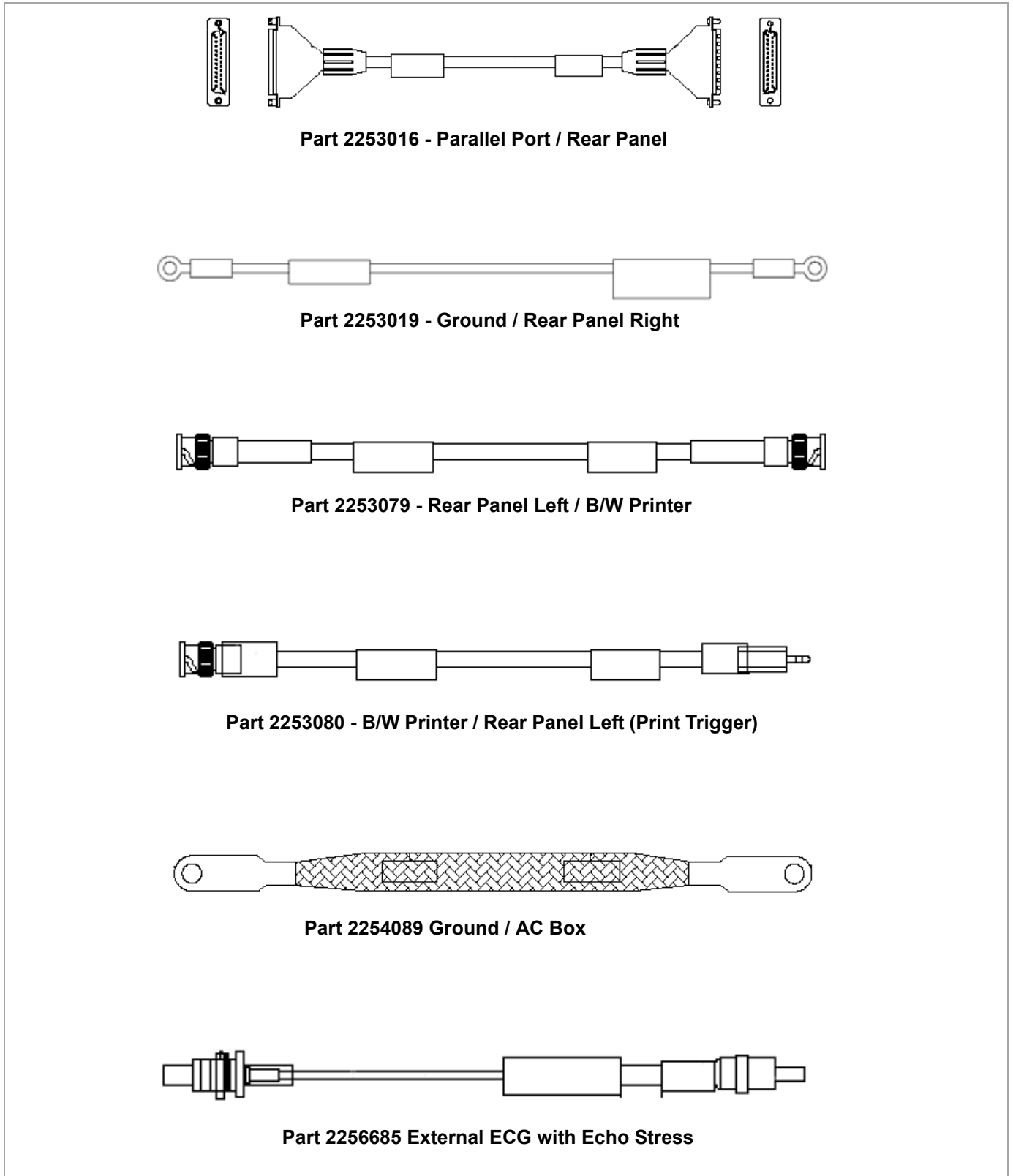

Figure 9-25 Cables - Diagram 5

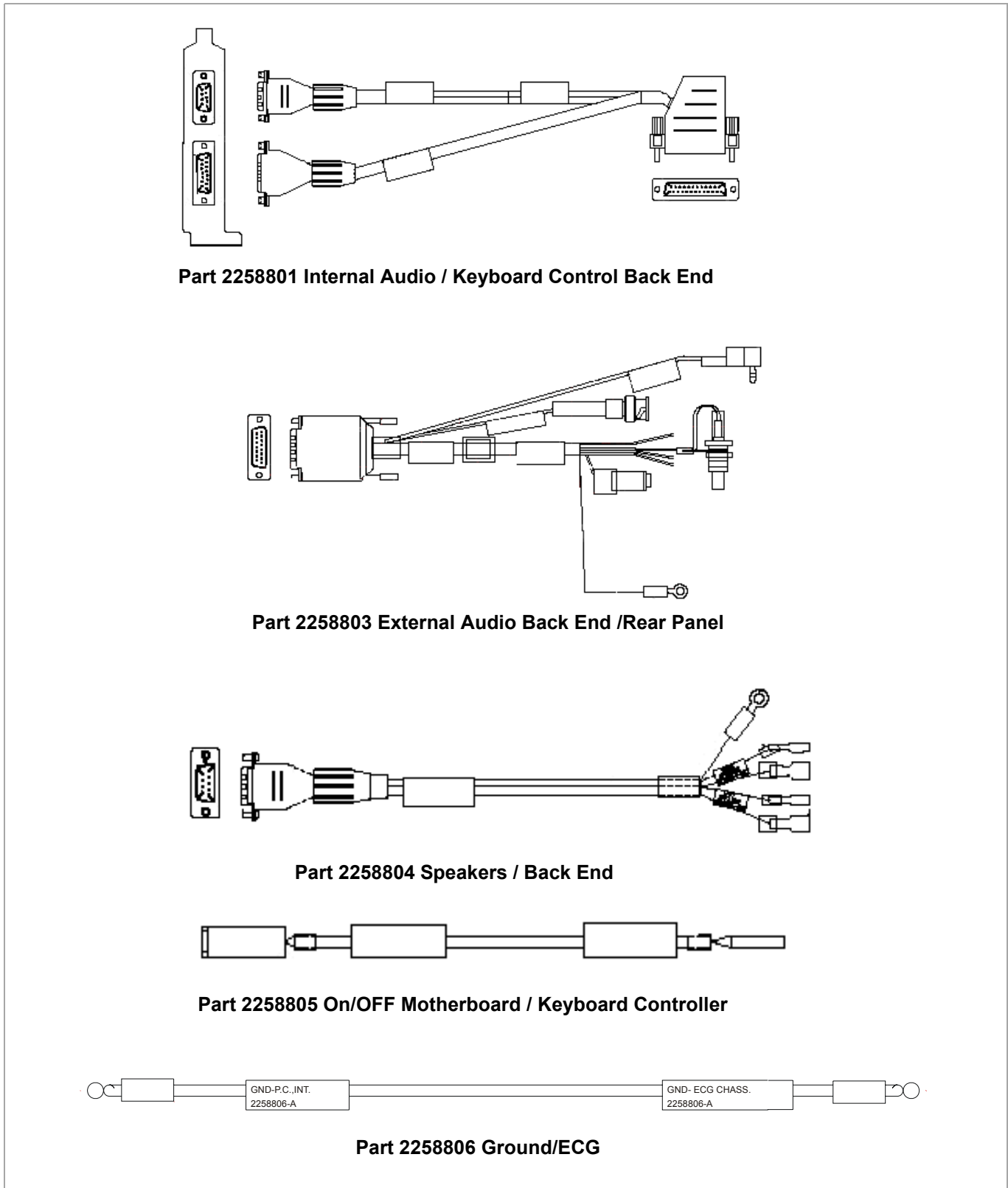

Figure 9-26 Cables - Diagram 6

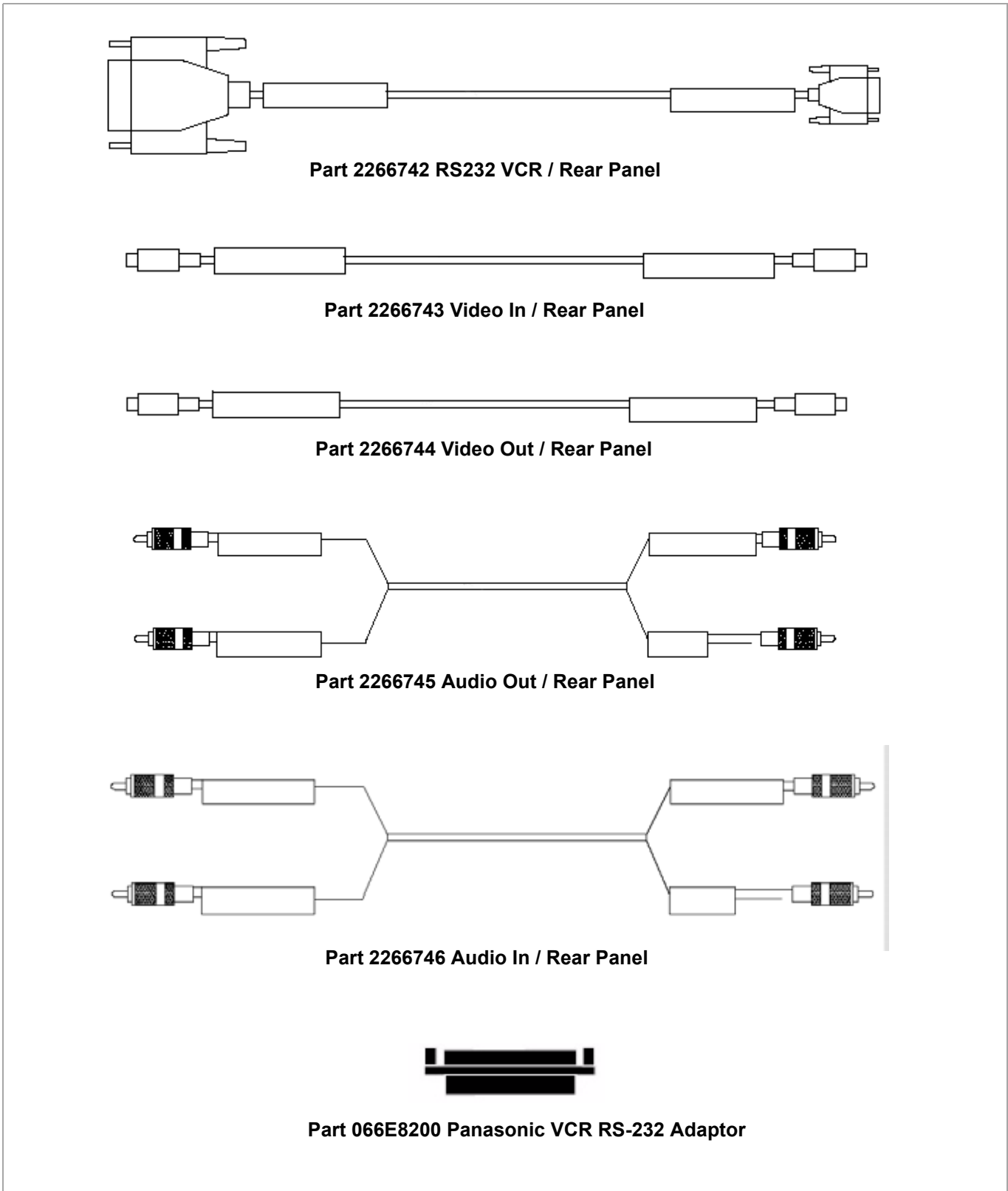

Figure 9-27 Cables - Diagram 7

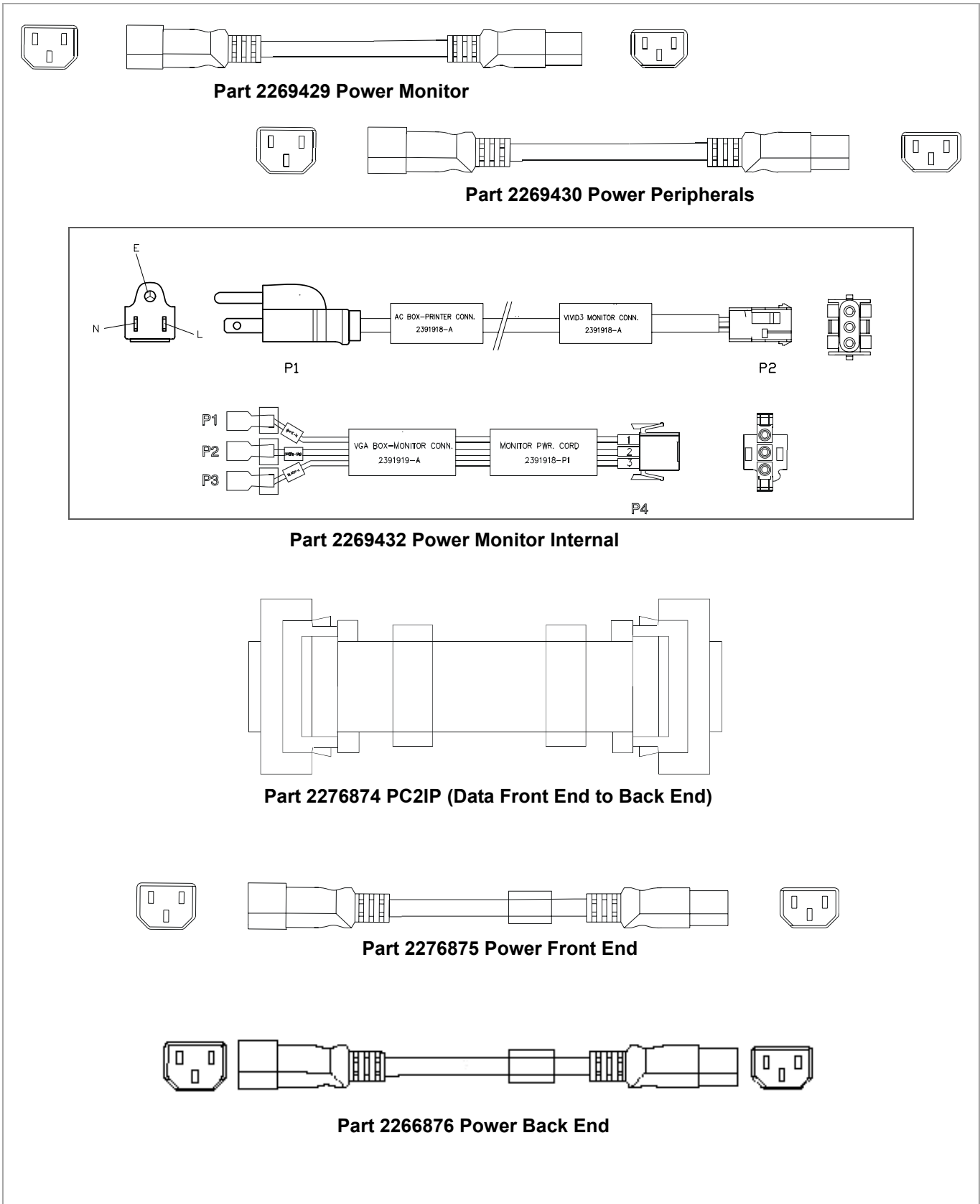
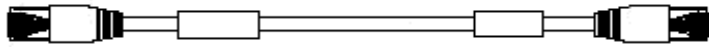
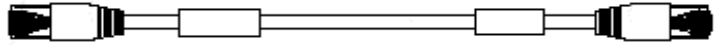

Figure 9-28 Cables - Diagram 8



Part 2283903 Network Rear Panel Right to Isolation Box



Part 2292972 Network Back End Rear Panel to Isolation Box (option)

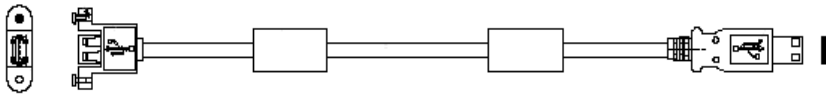

Part 2297905 USB Cable



Part 2298089 ECG Internal Com2

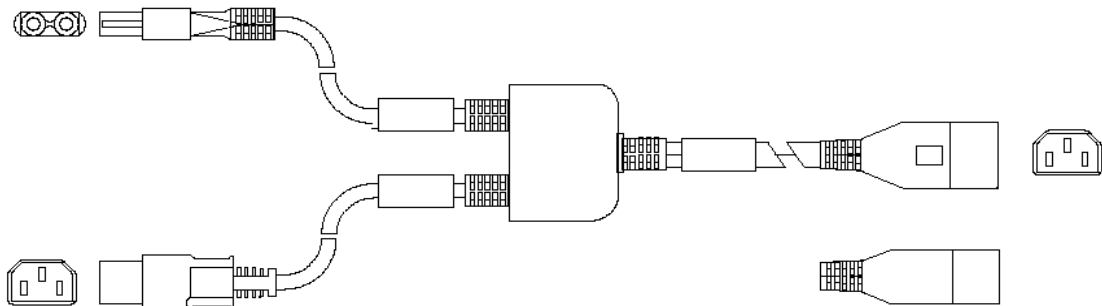

Part 2300857 Power Peripherals and Printer

Figure 9-29 Cables - Diagram 9

Table 9-10 Cables

P/N	Part Name	FRU	Pro BT03	BT03	Refer to
2252964	Cable: VGA Out	2	✓	✓	Figure 9-21 on page 9-21
2252965	Cable: VGA VIC/ PC	2	✓	✓	Figure 9-21 on page 9-21
2252966	Cable: Input Box / AC Distribution Box	2	✓	✓	Figure 9-21 on page 9-21
2252967	Cable: Soft Shutdown	2	✓	✓	Figure 9-21 on page 9-21
2252968	Cable: Ground / VIC	2	✓	✓	Figure 9-21 on page 9-21
2252969	Cable: Ground / Back-End	2	✓	✓	Figure 9-21 on page 9-21
2252970	Cable: Ground / Front End	2	✓	✓	Figure 9-22 on page 9-22
2252972	Cable: Fan (AC Dist. Box / Front End)	2	✓	✓	Figure 9-22 on page 9-22
2252973	Cable: Ground / Keyboard	2	✓	✓	Figure 9-22 on page 9-22
2252975	Cable: Keyboard Matrix / Control	2	✓	✓	Figure 9-22 on page 9-22
2252976	Cable: Keyboard/ VIC External Power	2	✓	✓	Figure 9-22 on page 9-22
2252981	Cable: Keyboard/ VIC Internal Power/ Back-End	2	✓	✓	Figure 9-23 on page 9-23
2252977	Cable: Back End / Keyboard Matrix (alphanumeric keyboard)	2	✓	✓	Figure 9-23 on page 9-23
2252978	Cable: Trackball / Back End Matrix Panel	2	✓	✓	Figure 9-23 on page 9-23
2252979	Cable: ECG - Back End Internal	2	✓	✓	Figure 9-23 on page 9-23
2252980	Cable: Patient I/O int. ECG - ECG/Phono	2	✓	✓	Figure 9-23 on page 9-23
2252982	Cable: ECG Int. Footswitch / Keyboard Control	2	✓	✓	Figure 9-23 on page 9-23
2253009	Cable: Com1: Back End / Rear Panel Left	2	✓	✓	Figure 9-24 on page 9-24
2253010	Cable: Ground / Rear Panel Left	2	✓	✓	Figure 9-24 on page 9-24
2253011	Cable: VIC / Rear Panel Left Col. Pr.	2	✓	✓	Figure 9-24 on page 9-24
2253012	Cable: Video / Rear Panel Left AC Dist. (Video Grabbing)	2	✓	✓	Figure 9-24 on page 9-24
2371429	Cable: Video / BEP rear (Frame Grabber)	1	a	a	Figure 9-21 on page 9-21

Table 9-10 Cables (Continued)

P/N	Part Name	FRU	Pro BT03	BT03	Refer to
2253014	Cable: AC Dist. / Rear Panel Right	2	✓	✓	Figure 9-24 on page 9-24
2253016	Cable: Parallel Port / Rear Panel	2	✓	✓	Figure 9-25 on page 9-25
2253019	Cable: Ground/ Rear Panel Right	2	✓	✓	Figure 9-25 on page 9-25
2253079	Cable: Rear Panel Left / B/W Printer	2	✓	✓	Figure 9-25 on page 9-25
2253080	Cable: B/W Printer / Rear Panel Left (Print Trig)	2	✓	✓	Figure 9-25 on page 9-25
2254089	Cable: Ground / AC Box	2	✓	✓	Figure 9-25 on page 9-25
2256477	Cable: ECG BEP Cable USA - External	1	✓	✓	Figure 9-25 on page 9-25
2256478	Cable: ECG BEP Cable Europe - External	1	✓	✓	Figure 9-25 on page 9-25
2256685	Cable: External ECG (with Echo Stress Option)	2	✓	✓	Figure 9-25 on page 9-25
2258801	Cable: Internal Audio / Keyboard Control Back End	2	✓	✓	Figure 9-26 on page 9-26
2258803	Cable: External Audio Back End / Rear Panel	2	✓	✓	Figure 9-26 on page 9-26
2258804	Cable: Speakers / Back End	2	✓	✓	Figure 9-26 on page 9-26
2258805	Cable: ON/OFF Motherboard / Keyboard Controller	2	✓	✓	Figure 9-26 on page 9-26
2258806	Cable: Ground / ECG	2	✓	✓	Figure 9-26 on page 9-26
066E8200	RS-232 Adaptor - for Panasonic VCR	1	✓	✓	Figure 9-27 on page 9-27
2266742	Cable: RS232 VCR / Rear Panel - for Sony VCR	2	✓	✓	Figure 9-27 on page 9-27
2266743	Cable: Video IN / Rear Panel	2	✓	✓	Figure 9-27 on page 9-27
2266744	Cable: Video OUT / Rear Panel	2	✓	✓	Figure 9-27 on page 9-27
2266745	Cable: Audio OUT / Rear Panel	2	✓	✓	Figure 9-27 on page 9-27
2266746	Cable: Audio IN / Rear Panel	2	✓	✓	Figure 9-27 on page 9-27
2269429	Cable: Power Monitor	N	✓	✓	Figure 9-28 on page 9-28
2269430	Cable: Power Peripherals	N	✓	✓	Figure 9-28 on page 9-28
2269431	Cable: Power Color Printer	2	✓	✓	
2269432	Cable: Power Monitor Internal	N	b	b	Figure 9-28 on page 9-28

Table 9-10 Cables (Continued)

P/N	Part Name	FRU	Pro BT03	BT03	Refer to
2276874	Cable: PC2IP (Data Front End to Back End)	2	✓	✓	Figure 9-28 on page 9-28
2296156	Cable: PC2IP to KB Controller	1	✓	✓	
2276875	Cable: Power Front End	2	✓	✓	Figure 9-28 on page 9-28
2276876	Cable: Power Back End	1	✓	✓	Figure 9-28 on page 9-28
2283903	Cable: Network Rear Panel Right to Isolation Box	1	✓	✓	Figure 9-29 on page 9-29
2292972	Cable: Network Back End Rear Panel to Isolation Box	N	✓	✓	Figure 9-29 on page 9-29
2297905	Cable: USB Cable	2	✓	✓	Figure 9-29 on page 9-29
2298089	Cable: ECG Internal COM-2	N	✓	✓	Figure 9-29 on page 9-29
2300857	Cable: Power Peripherals and Printer	2	✓	✓	Figure 9-29 on page 9-29
2269428-2	Cable: Cable Power Asia	1	✓	✓	
2269459-2	Cable: Cable Power - EU Plug	1	✓	✓	
2269460-2	Cable: Cable Power - AM Plug	1	✓	✓	
2415383-6	Cable: Cable Power - China Plug	1	✓	✓	

a. Applicable to RFI-configured systems *only*.

b. This cable kit includes two cables (Part No. 2391918 and 2391919) that should be connected together as one cable.

9-3-6 Software

Table 9-12 Software

P/N	Part Name	FRU	Pro BT03	BT03
2415386	S/W Kit - contains s/w for systems: Vivid™ 3, Vivid™ 4, and Vivid-i™	1	✓	✓

9-3-7 Probes

Table 9-14 Probes

P/N	Part Name	FRU	Pro BT03	BT03
H45001NE	Heart Sound Microphone	N	✓	✓
H40212LC	Probe: C358 (outside Japan)	1	✓	✓
E8386RK	Biopsy Kit for C358	N	✓	✓
H40602LM	Probe: C721 (Curved)	1	✓	✓
H40212LF	Probe: I739L Linear	1	✓	✓
H4701SZ	Probe: 3S Sector	1	✓	✓
H4000P H40422LB	Probe: 7S Sector	1	✓	✓
H40422LA H4901RA	Probe: 5S Sector	1	✓	✓
H40412LG	Probe: 10L (739L) Linear	1	✓	✓
H40412LH	Probe: 39A (12L) Linear	1	✓	✓
E83885MM	Biopsy Kit for 10L/12L	N	✓	✓
H4901PC	Probe: 10S	1	✓	✓
H44201TG	Probe: P509 (Japan)	1	✓	✓
H40212LM	Probe: T739L Linear	1	✓	✓
H40412LF	Probe: 7L (546L)	1	✓	✓
H45521DX	Probe: 6T OR	1	✓	✓
H45001YE	Probe: 8T (PED TEE)	1	✓	✓
H45521DY	Probe: 9T (PED TEE)	1	a	a
H45001YF	Probe: Adaptor PAMPTE/6Tv	1	✓	✓
H45001B	Probe: Wall Rack TEE	1	✓	✓
H4830JE	Probe: Pencil P2D	1	✓	✓
H4830JG	Probe: Pencil P6D	1	✓	✓
H40602LN	Probe: E721 OB/GYN	1	✓	✓
H45511NW	Probe: i8L Linear	1	✓	✓
H45511NT	Probe: i13L Linear	1	✓	✓

a. Applicable to RFI-configured systems only.

Section 9-4 Peripherals

Table 9-16 Approved Peripherals

P/N	Part Name	FRU	Pro BT03	BT03
H45011PT	VCR Mitsubishi HS-MD3000E S-VHS RS232C \PAL	2	✓	✓
H45011PN	VCR Mitsubishi HS-MD3000U S-VHS RS232C \NTSC	2	✓	✓
H45011PG	JVC VCR for side shelf - SR-S365U NTSC S-VHS	2	✓	✓
H45011PH	JVC VCR for side shelf - SR-S388E PAL S-VHS	2	✓	✓
H45001PG	VCR Cassette - S-VHS	N	✓	✓
H45001PW	Sony UP2800P PAL Color Video Printer - with shelf	2	✓	✓
H45001JC	Sony UP2800P PAL Color Video Printer - no shelf	2	✓	✓
H45001CL	Sony UP2950MD NTSC Color Video Printer - with shelf	2	✓	✓
H45001JD	Sony UP2950MD NTSC Color Video Printer - no shelf	2	✓	✓
H45001PY	Sony UP-21MD PAL/NTSC Color Video Printer - no shelf	2	✓	✓
H45001PZ	Sony UP-21MD PAL/NTSC Color Video Printer - with shelf	2	✓	✓
H45011CN	Shelf for Color Printer	2	✓	✓
H45001PJ	Color Paper for Color Printer	N	✓	✓
H45021FZ	Sony UPD 897MD B/W Video Printer	2	✓	✓
H45001PH	B/W Paper for B/W Printer	N	✓	✓
H45011PZ	HP Deskjet 6540/3 Color Printer	2	✓	✓

Section 9-5 Cabling Block Diagrams

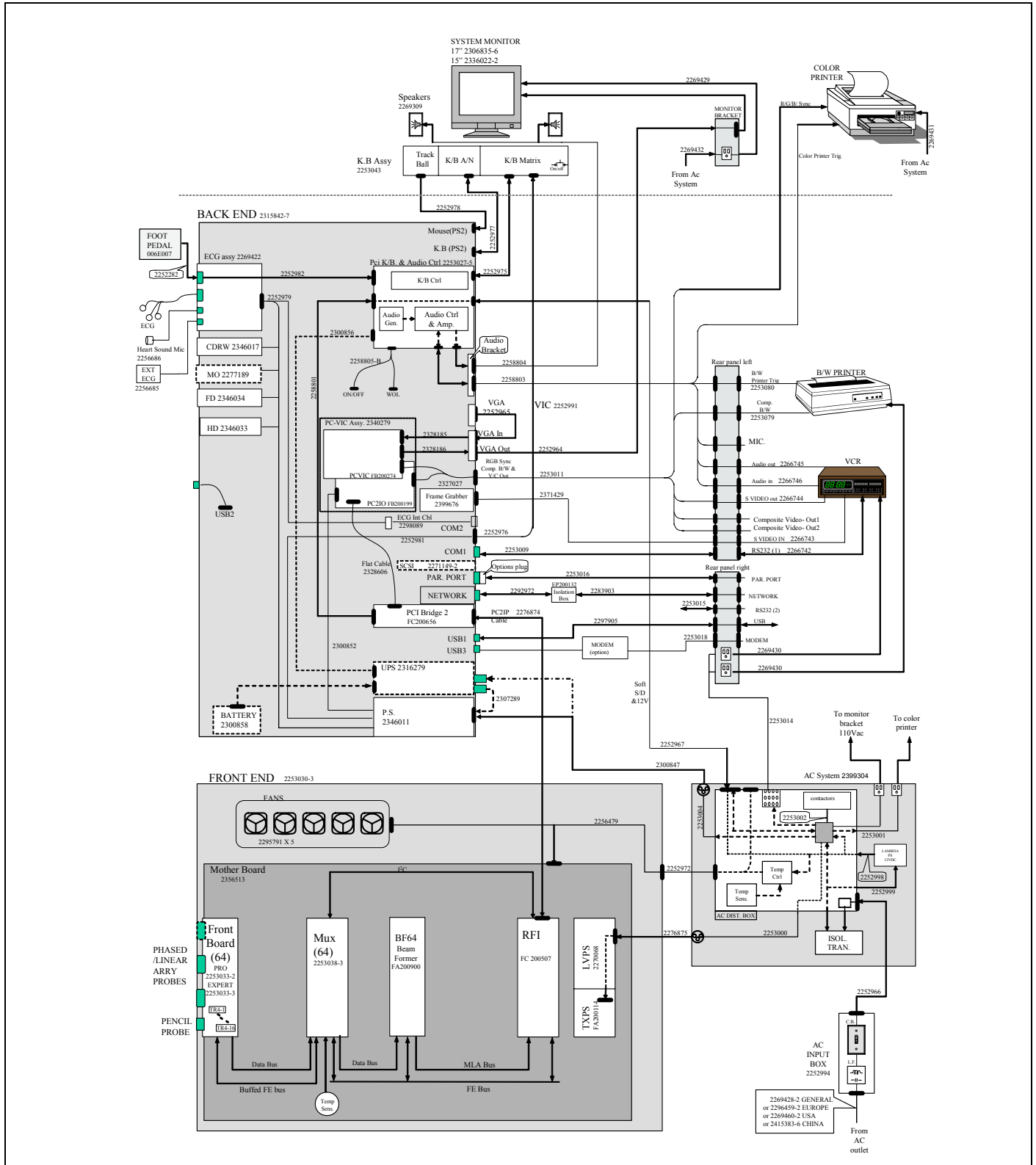

Figure 9-30 System Cabling Diagram - Vivid™ 3 BT03 (RFI Configuration)

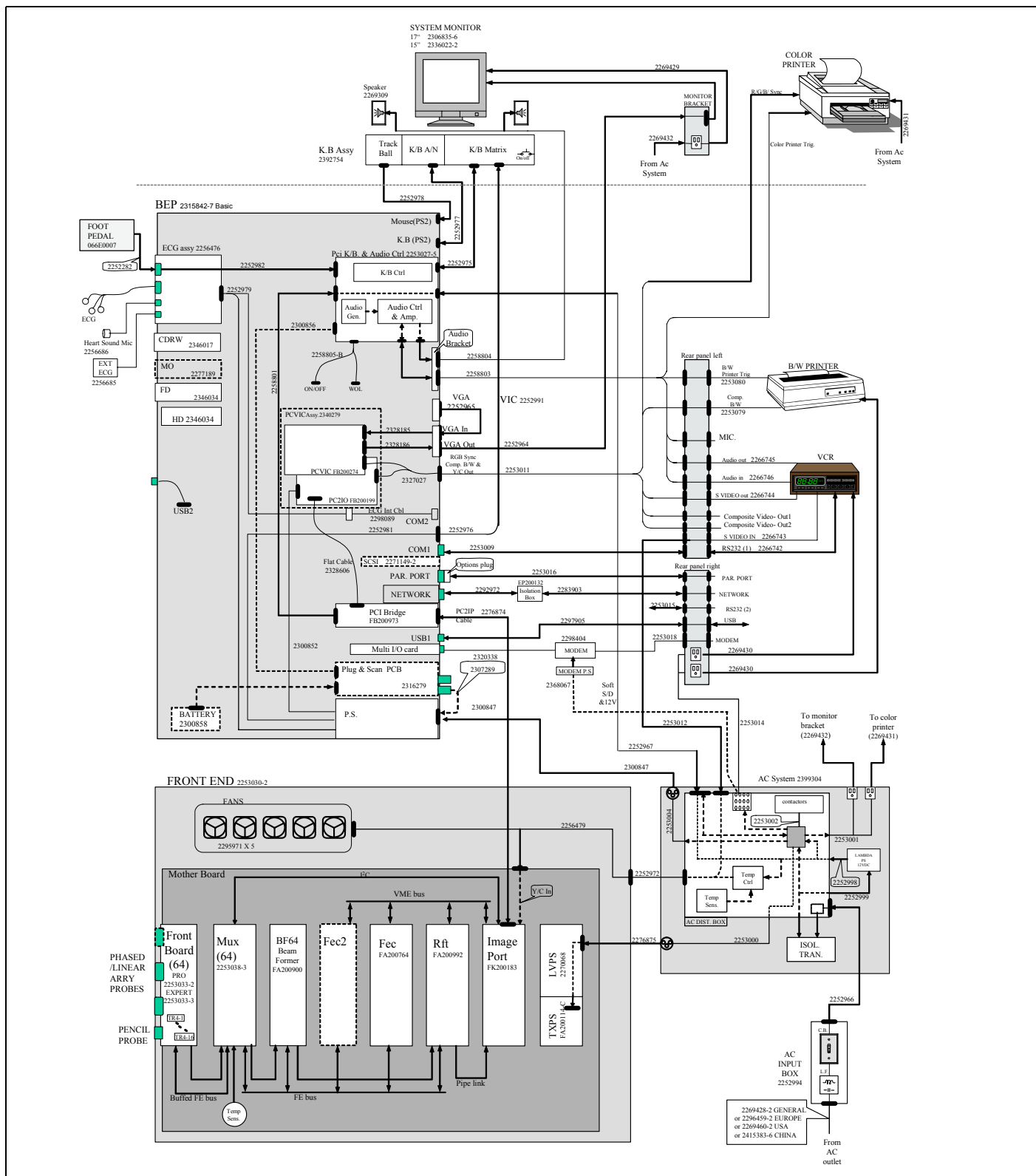

Figure 9-31 System Cabling Diagram - Vivid™ 3 BT03 (RFT Configuration)

Chapter 10

Periodic Maintenance

Section 10-1 Overview

10-1-1 Purpose of Chapter 10

This chapter describes Periodic Maintenance (PM) procedures for the Vivid™ 3 ultrasound scanner and its peripherals. These PM procedures are designed to protect your investment in the Vivid™ 3 system, and to ensure constant operation at maximum efficiency.

After delivery and installation of the Vivid™ 3 ultrasound unit, your service representative will contact you to schedule the first of several routine service visits. In addition to routine maintenance by trained Field Service Engineers (FSEs), it is recommended that the procedures described in this chapter be observed as part of your own internal routine maintenance program.

Table 10-1 Contents in Chapter 10

Section	Description	Page Number
10-1	Overview	10-1
10-2	Why Perform Periodic Maintenance Procedures?	10-2
10-3	Periodic Maintenance Schedule	10-3
10-4	Tools Required	10-6
10-5	System Periodic Maintenance	10-7
10-6	Probe Maintenance	10-14
10-7	Electrical Safety Tests	10-17
10-8	Excessive Current Leakage	10-29
10-9	PM and Safety Inspection Certificates	10-30

10-1-2 Warnings



DANGER: There are several places on the backplane, the AC distribution box, and the DC distribution box that could be dangerous. Be sure to disconnect the system power plug and to open the main circuit breaker before you remove any parts. Proceed with caution whenever power is ON and covers are removed.



DANGER: Do not pull out or insert circuit boards while mains power to the system is ON.



CAUTION: Practice good ESD prevention. Wear an anti-static strap when handling electronic parts and when disconnecting/connecting cables.



CAUTION: Do NOT operate the unit unless all board covers and frame panels are securely in place, to ensure optimal system performance and cooling. When covers are removed, EMI may be present.

Section 10-2 Why Perform Periodic Maintenance Procedures?

10-2-1 Keeping Records

It is good business practice that ultrasound facilities maintain records of periodic and corrective maintenance. The *Ultrasound Periodic Maintenance Inspection Certificate* provides the customer with documented confirmation that the Vivid™ 3 ultrasound scanner is regularly maintained on a periodic basis.

A copy of the *Ultrasound Periodic Maintenance Inspection Certificate* should be kept in the same room as the Vivid™ 3 ultrasound scanner, or nearby.

10-2-2 Quality Assurance

In order to gain accreditation from organizations such as the *American College of Radiology (USA)*, it is the customer's responsibility to have a Quality Assurance program in place for each scanner. The program must be directed by a medical physicist, the supervising radiologist/physician or appropriate designee.

Quality Control testing of the system must be conducted routinely. The same tests are performed regularly during each period, so that changes can be monitored over time and effective corrective action taken, if required.

The results of Quality Control testing, corrective action, and the effects of corrective action, must be documented and maintained on site.

Your GE Medical Systems Service Representative can help you with establishing, performing and maintaining records for a Quality Assurance program.

Section 10-3 Periodic Maintenance Schedule

10-3-1 How Often Should PM Procedures be Performed?

The **Periodic Maintenance Schedule** (provided in [Table 10-2](#) on page 10-4) specifies how often the Vivid™ 3 ultrasound scanner should be serviced, and outlines items requiring special attention. Annual periodic maintenance inspections are recommended. Each PM inspection requires approximately 2 hours for completion, excluding time needed for corrective action.

NOTE: *It is the customer's responsibility to ensure the periodic maintenance procedures are performed on the Vivid™ 3 ultrasound scanner as recommended in the Periodic Maintenance Schedule, in order to retain the high levels of safety, dependability, and system performance.*

Your GE Medical Systems Service Representative has an in-depth knowledge of your Vivid™ 3 ultrasound scanning system and can best provide competent, efficient service. Please contact us for further information, and to schedule routine maintenance servicing by our qualified professional FSEs.

The service procedures and recommended frequencies listed in the **Periodic Maintenance Schedule** assumes use of the Vivid™ 3 scanner for an average patient load (10-12 patients per day). However, this is not applicable if the system is used as a primary mobile unit which is transported between diagnostic facilities.

NOTE: *If conditions exist whereby typical usage and patient load is exceeded, it is strongly recommended to increase the periodic maintenance frequencies.*

Table 10-2 Periodic Maintenance Schedule

Service at Indicated Time	Daily	Weekly	Monthly	Annually	Notes
Clean Probes	●*				* or before each use
Clean Probe Holders	●				
Clean Air Filter			●		More frequently if necessary, depending on the environment
Inspect AC Mains Cable		*	●		*Mobile Unit Check Weekly
Inspect Cables and Connectors			●		
Clean Console			●		
Clean Monitor			●		
Inspect Wheels, Casters, Brakes and Swivel Locks	*		●		* Mobile Unit Check Daily
Check Control Console Movement	*		●		* Mobile Unit Check Daily
Console Current Leakage Checks				●	Also after corrective maintenance, or as required by your facility's QA program.
Peripheral Current Leakage Checks				●	Also after corrective maintenance, or as required by your facility's QA program.
Surface Probe Current Leakage Checks				●	Also after corrective maintenance, or as required by your facility's QA program.
Endocavity Probe (vaginal or anal) Current Leakage Checks					As prescribed in Probe Manual.
Transesophageal (TEE) Probe Current Leakage Checks					As prescribed in Probe Manual.
Surgical Probe Current Leakage Checks					As prescribed in Probe Manual.
Measurement Accuracy Checks				●	Also after corrective maintenance, or as required by your facility's QA program.
Probe/Phantom Checks				●	Also after corrective maintenance, or as required by your facility's QA program.
Functional Checks				●	Also after corrective maintenance, or as required by your facility's QA program.

Examine the following on a monthly basis:

- Connectors on cables - for any mechanical defects.
- The entire length of electrical and power cables - for cuts or abrasions.
- Equipment - for loose or missing hardware.
- The keyboard - for defects.
- Brakes - for defective operation.



DANGER: To avoid electrical shock hazard, do not remove the panels or covers from the machine. This servicing must be performed by qualified service personnel *only*. Failure to comply, could result in serious injury!



DANGER: If any defects are observed or any system malfunctions occur, **DO NOT** operate the equipment. Inform a qualified service engineer immediately.

Section 10-4 Tools Required

10-4-1 Special Tools, Supplies and Equipment

10-4-1-1 Specific Requirements for Periodic Maintenance

Table 10-3 Overview of Requirements for Periodic Maintenance

Tool	Part Number	Comments
Digital Volt Meter (DVM)		
Anti Static Kit	46-194427P231 46-194427P279 46-194427P369 46-194427P373 46-194427P370	Kit includes: anti-static mat, wrist strap and cables for 220 to 240 V system 3M #2204 Large adjustable wrist strap 3M #2214 Small adjustable wrist strap 3M #3051 conductive Ground cord
Anti Static Vacuum Cleaner	46-194427P278 46-194427P279	120V 230V
Air Filter	2256176	Air intake
Safety Analyzer	46-285652G1	DALE 600 KIT (or equivalent) for electrical tests
SVHS VCR Cassette	E7010GG E7010GF	60 minutes 120 minutes
SVHS VCR Head Cleaner		See VCR user manual for requirements
5.25" MOD MEDIA	2277190	Blank 2.3 M disk Blank 5.2 M disk
5.25" MOD Disk Cleaning Kit (Vingmed)	066E0674	Sony MOA-D51
QIQ Phantom	E8370RB	RMI Grayscale Target Model 403GS
B/W Printer Cleaning Sheet		See printer user manual for requirements
Color Printer Cleaning Sheet		See printer user manual for requirements
Disposable Gloves		
System Service Code		Required in order to enter system diagnostics
User Manual		Current revision
Service Manual		Current revision

Section 10-5 System Periodic Maintenance

10-5-1 Preliminary Checks

The preliminary checks take approximately 15 minutes to perform. Refer to the *Vivid™ 3 Pro/Vivid™ 3 Expert User Manual* whenever necessary.

Table 10-4 System Preliminary Checks

Step	Item	Description
1	Ask & Listen	Ask the customer if they have any problems or questions about the equipment.
2	Paperwork	Fill in the appropriate details at the top of the Vivid™ 3 Preventative Maintenance Inspection Certificate (see page 10-30). Note all probes and system options.
3	Power-up	Turn the system power ON and verify that all fans and peripherals turn on. Watch the displays during power up to verify that no warning or error messages are displayed.
4	Probes	Verify that the system properly recognizes all probes.
5	Displays	Verify proper display on the monitor and touch panel.
6	Presets	Back-up all customer presets on an CD-RW.

10-5-2 Functional Checks

The functional checks take approximately 60 minutes to perform. Refer to the *Vivid™ 3 Pro/Vivid™ 3 Expert User Manual* whenever necessary.

NOTE: Refer to [Chapter 4 - Functional Checks](#), for additional details about the functional checks described in this section.

10-5-2-1 System Checks

Table 10-5 System Functional Checks

Step	Item	Description
1	2D-Mode	Verify basic 2D-Mode operation. Check the basic system controls that affect this mode of operation.
2	CF-Mode	Verify basic CF-Mode (Color Flow Mode) operation. Check the basic system controls that affect this mode of operation.
3	Doppler Modes	Verify basic Doppler operation (PW and CW if available). Check the basic system controls that affect this mode of operation.
4	M-Mode	Verify basic M-Mode operation. Check the basic system controls that affect this mode of operation.
5	Applicable Software Options ^a	Verify the basic operation of all optional modes such as Multi-Image, 3D, Contrast, Harmonics, Cine, Stress Echo,... etc. Check the basic system controls that affect each options operation.
6	Probe Elements	Perform an Element Test on each probe to verify that all the probe elements and system channels are functional.
7	System Diagnostics	Perform the Automatic Test to verify that all boards are functioning according to specifications.
8	Keyboard Test	Perform the Keyboard Test Procedure (external and alphanumeric) to verify that all keyboard controls are OK.
9	Monitor	Verify basic Monitor display functions. Refer to Chapter 3 of the <i>Vivid™ 4 User Manual</i> .
10	Measurements	Scan a gray scale phantom and use the measurement controls to verify distance and area calculation accuracy. Refer to Chapter 18 of the <i>Vivid™ 4 User Manual</i> , for measurement accuracy specifications.

a. Some software may be considered as standard, depending upon system model configuration

10-5-2-2 Peripheral/Option Checks

If any peripherals or options are not part of the system configuration, the following checks can be omitted. Refer to the *Vivid™ 4 User Manual* for a list of approved peripherals/options.

Table 10-6 GE Approved Peripheral/Hardware Option Functional Checks

Step	Item	Description
1	VCR	Verify record/playback capabilities of the VCR. Clean heads and covers if necessary.
2	B/W Printer	Verify hardcopy output of the B/W video page printer. Clean heads and covers if necessary.
3	Color Printer	Verify hardcopy output of the Color video page printer. Clean heads and covers if necessary.
4	DICOM	Verify that DICOM is functioning properly. Send an image to a DICOM device.
5	InSite/iLinq	Verify that InSite is functioning properly. Ensure two-way remote communications. (Warranty & Contract Customers only)
6	Footswitch	Verify that the footswitch is functioning as programmed. Clean as necessary.
7	ECG	Verify basic operation with customer

10-5-3 Input Power Checks

10-5-3-1 Mains Cable Inspection

Table 10-7 Mains Cable Inspection

Step	Item	Description
1	Unplug Cord	Disconnect the mains cable from the wall and system.
2	Mains Cable	Inspect the mains cable and its connectors for any damage.
3	Terminals	Verify that the LINE, NEUTRAL and GROUND wires are properly attached to the terminals, and that no strands may cause a short circuit.
4	Inlet Connector	Verify that the Inlet connector retainer is functional.

10-5-4 Cleaning

10-5-4-1 General Cleaning

Table 10-8 General Cleaning

Step	Item	Description
1	External Panels	On a weekly basis, moisten a soft, non-abrasive folded cloth with a mild, general purpose, non-abrasive soap and water solution or general purpose disinfectant. Wipe down the top, front, back and both sides of the unit. Do not spray any liquid directly onto the unit!
2	Monitor	On a weekly basis, apply glass cleaner to a soft, non-abrasive folded cloth. Gently wipe the monitor face.
3	Console	Frequent and diligent cleaning of the Vivid™ 3 ultrasound unit reduces the risk of spreading infection from person to person, and also helps to maintain a clean working environment. Prior to cleaning, turn OFF the power to the system. Use a fluid detergent in warm water on a soft, damp cloth to carefully wipe the entire system. Be careful not to get the cloth too wet so that moisture does not enter the console.
4	Control Panel and Keyboard	<p>Control Panel: On a weekly basis, moisten a soft, non-abrasive folded cloth or sponge with a mild, general purpose, non-abrasive soap and water solution or general purpose disinfectant. (Do not use any solution containing abrasive powder or strong chemicals such as, acid or alkaline). Squeeze excess liquid from the cloth/sponge, then wipe down the Control Panel. Do not spray any liquid directly onto the Control Panel! Rinse the cloth/sponge with clean running water and wipe the Control Panel again. Use a dry, soft, lint-free cloth to dry the Control Panel. Wait for the Control Panel surface to dry completely.</p> <p>Keyboard: Clean the keyboard as described (above) for cleaning the Control Panel. Note: In the event that disinfection is required or any stubborn stains remain, absorb a small quantity of isopropyl rubbing alcohol on a soft, dust-free cloth. Wipe the surface of the keycaps with the cloth, making sure that no liquid drips on or between the keys. Allow to dry.</p>
5	Probe Holder	Clean the probe holders with warm water and a damp cloth to remove all traces of gel (soaking may be required to remove excess gel).

10-5-4-2 Air Filter Cleaning

Regular cleaning of the Vivid™ 3 scanner's air filter will ensure that the filter does not become clogged - this would otherwise cause the system to overheat and reduce system performance and reliability.

NOTE: It is recommended that the air filter cleaning procedure is performed once every 3 months (quarterly). However, the required frequency for air filter cleaning will vary in accordance with environmental conditions.

Table 10-9 Air Filter Cleaning

Step	Item	Description
1	Air Filter	Remove the air filter located at the front of the scanner, above the probe connector sockets. Clean the air filter as follows: shake it in an area away from the system, wash with a mild soapy solution, rinse, and air dry.
2	Air Filter	Install the clean air filter. Refer to Chapter 8 - Replacement Procedures for air filter installation instructions.

NOTE: For convenience (or if the air filter is excessively dirty), replacement filters are available. Refer to [Chapter 9 - Renewal Parts](#) for the air filter replacement part number.

10-5-5 Physical Inspection

Table 10-10 Physical Checks

Step	Item	Description
1	Labeling	Verify that all system labeling is present and in readable condition.
2	Scratches and Dents	Inspect the console for dents, scratches or cracks. Use touch-up paint, as required.
3	Monitor	Clean the monitor with a soft cloth dampened with mild detergent and water. Repeat using only water, and wipe with a dry cloth. Inspect the monitor for scratches and raster burns.
4	Probe Holders	Clean the probe holders with warm water and a damp cloth to remove all traces of gel.
5	Control Console	Power-down and unplug the system. Inspect the keyboard and control console. Note any damaged or missing items. Fix any loose buttons, and verify that the control console light bulb is working. Replace faulty components, as required. Clean the console and keyboard.
6	Control Console Movement	Verify ease of control console (Operator I/O Panel) movement in all acceptable directions. Ensure that it latches in position, as required.
7	Wheels and Brakes	Check all wheels and castors for wear and verify operation of the foot brake to stop the unit from moving, and release mechanism. Check all wheel locks and wheel swivel locks for proper operation.
8	Fans	Check that the FE crate cooling fans, BE fan and peripheral fans are operating and clean.
9	MOD	Clean the drive head and media with the vendor-supplied cleaning kit. Advise the user to repeat this often, to prevent future problems. MOD disks must be stored away from dust and cigarette smoke. Do not use alcohol or benzene to clean the MOD cartridge.
10	CD Drive	Clean the drive head and media with the vendor-supplied cleaning kit. Advise the user to repeat this often, to prevent future problems. CDs must be stored away from dust and cigarette smoke. Do not use alcohol or benzene to clean the CD drive.
11	Rear Panel Connectors	Check the rear panel connectors for bent pins, loose connections and loose or missing hardware. Verify that the labeling is in good condition.
12	AC Unit	Check the AC board connectors and the associated cabling for good connection and proper insulation. Verify that the connections are secured.
13	BEP Rear Connector	Check the BEP rear connector for bent pins. Screw all the cable connectors tightly to the connector sockets on the panel.
14	Cables and Connectors	Check all internal cable harnesses and connectors for wear, and secure connector seating. Pay special attention to footswitch assembly and probe strain or bend reliefs.
15	Power Cord	Check the power cord for cuts, loose hardware, tire marks, exposed insulation or other deterioration, and verify continuity. Tighten the clamps that secure the power cord to the unit and the outlet plug to the cord. Replace the power cord and clamp, as required.
16	Shielding and Covers	Check to ensure that all EMI shielding, internal covers, panels and screws are in place. Missing covers and hardware can cause EMI/RFI problems during scanning.
17	Peripherals	Check and clean the peripherals according to the manufacturer's directions. To prevent EMI or system overheating, dress the peripheral cables inside the peripheral cover.
18	External Microphones	Check for proper operation of any external microphones by recording an audio test.

10-5-6 Diagnostic Checks (Optional)

To complete the periodic maintenance checks, perform the diagnostic tests as described in [Chapter 7 - Diagnostics/Troubleshooting](#).

- Review the system error log for any problems.
- Check the temperature log to see if there are any trends that could cause problems in the future.

Section 10-6 Probe Maintenance



WARNING: Any evidence of wear on a probe indicates that it must not be used. Improper handling may easily damage ultrasound probes. See the Vivid™ 3 Pro/Vivid™ 3 Expert User Manual and also refer to the probe manufacturer's handling instructions, for more details.

Failure to follow these precautions can result in serious injury and equipment damage. Failure to properly handle or maintain a probe may also void its warranty.

10-6-1 Probe Checks

Table 10-11 Probe Checks

Step	Item	Description
1	Probe Holder	Check there are no traces of gel on the probe holders. If any gel present, clean the probe holders with warm water and a damp cloth to remove all traces of gel (soaking may be required to remove excess gel).
2	Probes	Check all the probes for wear and tear on the lens, cable and connector. Look for bent pins on the connector and in the connector socket on the unit. Remove any dust from inside the connector sockets. Verify that the EMI fingers around the probe connector socket housing are intact. Check the probe locking mechanism and probe switch. Perform a visual check of transducer pins and connector sockets before connecting a probe. Verify that the system properly recognizes all probes.

10-6-2 Probe Handling

All Vivid™ 3 probes are designed and manufactured to provide trouble-free, reliable service. To ensure this, the correct handling of probes is important and the following points should be noted:

- Do not drop a probe or strike it against a hard surface, as this may damage the probe elements and the acoustic lens, or may crack the housing.
- Do not use a cracked or damaged probe. Any evidence of wear indicates the probe must *not* be used. Call your field service representative immediately for a replacement.
- Perform a visual check of the probe pins and system sockets before plugging in a probe
- Avoid pulling, pinching or kinking the probe cable, since a damaged cable may compromise the electrical safety of the probe.
- To avoid the risk of a probe accidentally falling, do not allow the probe cables to become entangled with, or to be caught in the wheels of the system.
- Protect the probe when moving the unit.
- Use a soft cloth and warm, soapy water to clean the probe.

Note: For detailed information on handling endocavity probes, refer to the appropriate supplementary instructions for each probe.

10-6-3 Basic Probe Care

The *Vivid™ 3 Pro/Vivid™ 3 Expert User Manual* and the individual probe manufacturers' handling instructions provide a complete description of probe care, maintenance, cleaning and disinfection. Ensure that you are completely familiar with the proper care of GE Medical Systems probes.



WARNING: Any evidence of wear on a probe indicates that it must not be used. Ultrasound probes can be easily damaged by improper handling. See the *Vivid™ 3 Pro/Vivid™ 3 Expert User Manual* and also refer to the probe manufacturer's handling instructions, for more details.

Failure to follow these precautions can result in serious injury and equipment damage. Failure to properly handle or maintain a probe may also void its warranty.

TEE and Interoperative probes often have special usage considerations; always refer to the individual probe manufacturers' handling instructions/user manual.

10-6-4 Probe Cleaning and Disinfecting



WARNING: Always disinfect a defective probe, as follows:

- **When receiving the probe from the customer**
(to protect the service personnel from possible contamination)
- **Before returning the probe to the manufacturer.**
Be sure to tag the probe as being disinfected.



CAUTION: To help protect yourself from blood-borne diseases when cleaning and handling probes, wear approved, non-allergic disposable gloves.

Note: **IMPORTANT** - For probe cleaning and disinfecting instructions, refer to the individual probe Users Manual (or care instructions supplied with the probe). See also the information provided in Chapter 13 of the *Vivid™ 3 Pro/Vivid™ 3 Expert User Manual*.

Note: Failure to follow the prescribed cleaning/disinfection procedures will void the probe's warranty.

10-6-5 Returning and Shipping of Defective Probes



WARNING: Always disinfect a defective probe before returning it to the manufacturer. Be sure to tag the probe as being disinfected.



CAUTION: To help protect yourself from blood-borne diseases when cleaning and handling probes, wear approved, non-allergic disposable gloves.

Equipment being returned must be properly clean and free of blood and other potentially infectious contaminants.

GEMS policy states that body fluids must be properly removed from any part or equipment prior to shipment. GEMS employees, as well as customers, are responsible for ensuring that parts/equipment have been properly decontaminated prior to shipment. Under no circumstances should a part or equipment be shipped before being visibly clean and properly disinfected.

The purpose of the regulation is to protect employees in the transportation industry, as well as the persons who will receive and/or open the package.

NOTE: *The US Department of Transportation (DOT) has ruled that "items that were saturated and/or dripping with human blood that are now caked with dried blood; or which were used or intended for use in patient care" are "regulated medical waste" for transportation purposes and must be transported as a hazardous material.*

Section 10-7 Electrical Safety Tests

10-7-1 Safety Test Overview

The electrical safety tests in this section are based on and conform to NFPA 99 (For USA) and IEC 60601-1 Medical Equipment Safety Standards. They are intended for the electrical safety evaluation of cord-connected, electrically operated, patient care equipment. If additional information is needed, refer to the NFPA 99 (for USA) and IEC 60601-1 documents.



WARNING: THE USER MUST ENSURE THAT THE SAFETY INSPECTIONS ARE PERFORMED AT LEAST EVERY 12 MONTHS ACCORDING TO THE REQUIREMENTS OF THE PATIENT SAFETY STANDARD IEC-EN 60601-1. ONLY TRAINED PERSONS ARE ALLOWED TO PERFORM THE ABOVE-MENTIONED SAFETY INSPECTIONS.



CAUTION: To avoid the risk of electrical shock, the unit under test must not be connected to other electrical equipment. Remove all interconnecting cables and wires. The operator and patient must not come into contact with the unit while the tests are being performed.



CAUTION: Possible risk of infection. Do not handle soiled or contaminated probes and other components that have been in patient contact. Follow appropriate cleaning and disinfecting procedures before handling the equipment.

Test the system, peripherals and probes for leakage current.



WARNING: EXCESSIVE LEAKAGE CURRENT CAN CAUSE FATAL INJURY.

HIGH LEAKAGE CURRENT CAN INDICATE DEGRADATION OF INSULATION OR OTHER PART AND COULD POTENTIALLY CAUSE ELECTRICAL FAILURE. DO NOT USE PROBES OR EQUIPMENT THAT HAVE EXCESSIVE CURRENT LEAKAGE.

To minimize the risk of a probe causing electrical shock, observe the following recommendations:

- Do not use a probe that is cracked or damaged in any way
- Check probe leakage current, as shown below:

Probe	Frequency for Checking
Surface	Once per year
Endocavitary	Twice per year
Any probe	Whenever damage is suspected

10-7-2 GEMS Current Leakage Limits

The following limits are summarized for NFPA 99 (for USA) and IEC 60601-1 Medical Equipment Safety Standards. These limits are GEMS standards and in some cases are lower than the above standards listed.

Table 10-12 Chassis Current Leakage Limits - Accessible Metal Surfaces

Country	Normal Condition	Open Ground	Reverse Polarity	Open Neutral
USA	N/A	0.3 mA	0.3 mA	N/A
Other	0.1 mA	0.5 mA	0.5 mA	0.5 mA

**Table 10-13 Type BF Applied Part Current Leakage Limits
 - Non-Conductive (Floating) Surface and Cavity Probes**

Country	Normal Condition	Open Ground	Reverse Polarity	Open Neutral	Mains Applied ^a
USA	0.05 mA	0.05 mA	0.05 mA	0.05 mA	N/A
Other	0.1 mA	0.5 mA	0.5 mA	0.5 mA	5.0 mA

- a. Mains Applied is the Sink Leakage Test. In this test, mains (supply) voltage is supplied to the part or equipment to determine the amount of current that will pass (sink) to Ground if a patient comes into contact with the part.

Table 10-14 Type CF Applied Part Current Leakage Limits - Surgical Probes and ECG Connections

Country	Normal Condition	Open Ground	Reverse Polarity	Open Neutral	Mains Applied ^a
USA	0.01 mA	0.05mA	0.05 mA	N/A	0.025 mA
Other	0.01 mA	0.05 mA	0.05 mA	0.05 mA	0.05 mA

- a. Mains Applied is the Sink Leakage Test. In this test, mains (supply) voltage is supplied to the part or equipment to determine the amount of current that will pass (sink) to Ground if a patient comes into contact with the part.

10-7-3 Outlet Test Wiring Arrangement - USA & Canada

Test all outlets in the area for proper grounding and wiring arrangement by plugging in the neon outlet tester and noting the combination of lights that are illuminated. Any problems found should be reported to the hospital immediately and the receptacle should not be used.

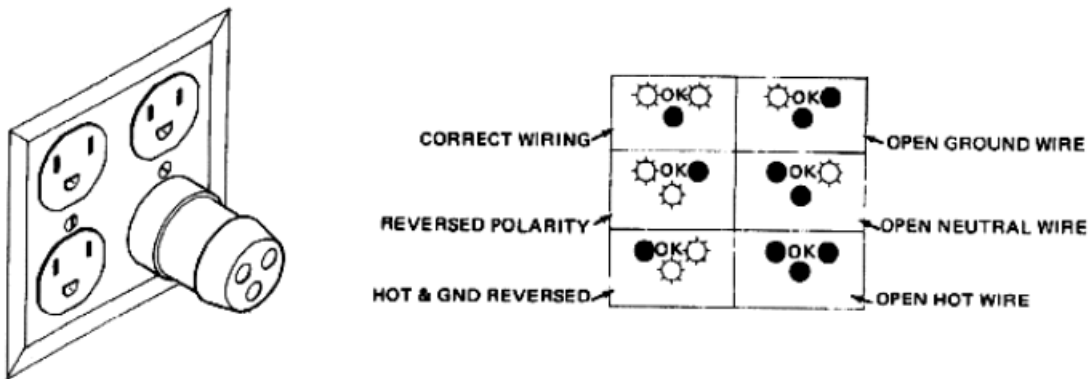

Figure 10-1 Typical Outlet Tester

NOTE: No outlet tester can detect the condition in which the Neutral (grounded supply) conductor and the Grounding (protective earth) conductor have been reversed. If later tests indicate high current leakages, this should be suspected as a possible cause and the outlet wiring should be visually inspected.

10-7-4 Grounding Continuity

CAUTION Electric Shock Hazard!
 The patient or operator must not come into contact with the equipment during this test.

Measure the resistance from the third pin of the attachment plug to the exposed metal parts of the case. The Ground wire resistance should be less than **0.2 Ohms**. Refer to the procedure in the IEC 601-1.1.

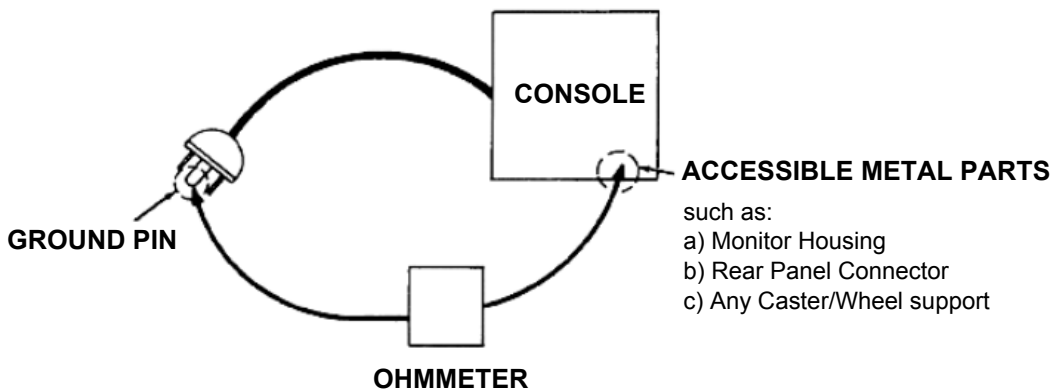

Figure 10-2 Ground Continuity Test

10-7-4-1 Ground Continuity Testing - Generic Procedure

Follow these steps to test the Ground wire resistance:

- 1.) Turn the Vivid™ 3 unit OFF.
- 2.) Connect one of the Ohmmeter probes to the tested AC wall outlet (Ground pin).
- 3.) Using the other Ohmmeter probe, touch the exposed metal part of the Vivid™ 3 unit.
- 4.) Set the meter **Function** switch to the **Resistance** position.
- 5.) Measure and record the Ground wire resistance.
This should be less than 0.2 Ohms.

10-7-5 Chassis Current Leakage Test

10-7-5-1 Definition

This test measures the current that would flow in a grounded person who touched accessible metal parts of the bedside station, if the Ground wire should break. The test verifies the isolation of the power line from the chassis.

The meter is connected from accessible metal parts of the case to Ground. Measurements should be made with the unit ON and OFF, with the power line polarity Normal and Reversed. Record the highest reading.



DANGER: Electric Shock Hazard.

When the meter's Ground switch is OPEN, do not touch the unit!



CAUTION: To avoid damaging the unit, never switch the polarity and the neutral status when the unit is powered ON. Be sure to turn the unit power OFF before switching them using the **Polarity** switch and/or the **Neutral** switch.

10-7-5-2 Generic Procedure

The test verifies the isolation of the power line from the chassis. The testing meter is connected from accessible metal parts of the case to Ground. Measurements should be made with the unit ON and OFF, with the power line polarity Normal and Reversed. Record the highest reading of current.

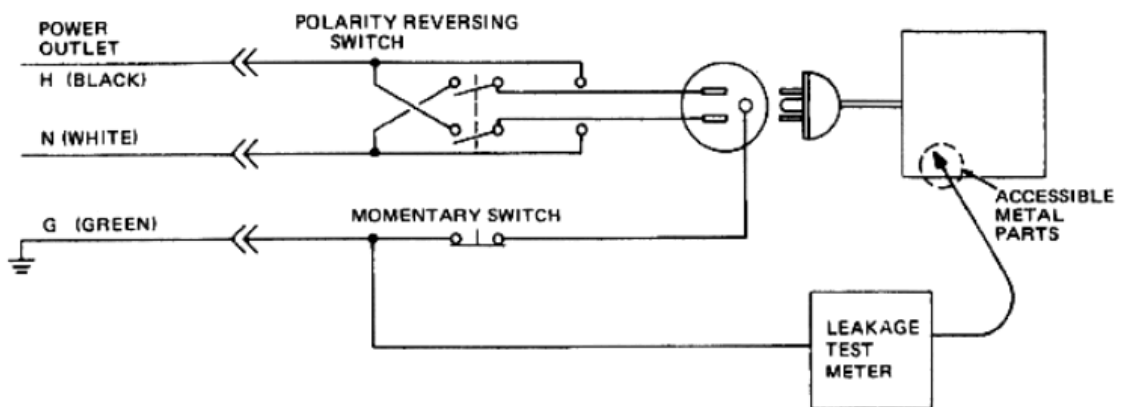

**Figure 10-3 Set Up for Chassis Source Current Leakage, IEC 601-1 Clause 19
Continuous Current Leakages and Patient, Auxiliary Currents**

When using the Microguard or a similar test instrument, its power plug may be inserted into the wall outlet and the equipment under test be plugged into the receptacle on the panel of the meter. This places the meter in the grounding conductor and the current flowing from the case to Ground will be indicated in any of the current ranges. The maximum allowable limit for chassis source leakage is shown in [Table 10-12](#) on page 10-18.

10-7-5-3 Data Sheet for Chassis Source Current Leakage

The Chassis Source Current Leakage Test passes when all readings measure less than the values shown in [Table 10-12](#). Record all data on the [Vivid™ 3 Preventative Maintenance Inspection Certificate](#) (see page 10-30).

Table 10-15 Typical Data Sheet for Chassis Source Current Leakage Test

Unit Power	Tester Polarity Switch	Tester Neutral or Ground Switch	Test 1 Probe Connector	Test 2 Caster Wheel	Test 3 CRT	Test 4 (Optional)	Test 5 (Optional)
Enter Name of tested peripheral here:							
ON	NORM	OPEN					
ON	NORM	CLOSED					
ON	REV	OPEN					
ON	REV	CLOSED					
OFF	NORM	OPEN					
OFF	NORM	CLOSED					
OFF	REV	OPEN					
OFF	REV	CLOSED					

10-7-6 Isolated Patient Lead (Source) Leakage – Lead-to-Ground

10-7-6-1 Definition

This test measures the current which would flow to Ground from any of the isolated ECG leads. The meter simulates a patient who is connected to the monitoring equipment and is grounded by touching some other grounded surface.



CAUTION: To avoid damaging the unit, never switch the polarity and the neutral status when the unit is powered ON. Be sure to turn the unit power OFF before switching them, using the **Polarity** switch and/or the **Neutral** switch.

10-7-6-2 Generic Procedure

Measurements should be made with the Ground **Open** and **Closed**, with the Vivid™ 3 unit **ON** and **OFF**, and with the power line polarity **Normal** and **Reversed**. Record the highest reading. For each combination, the operating controls (such as, the lead switch) should be operated to find the worst case condition.

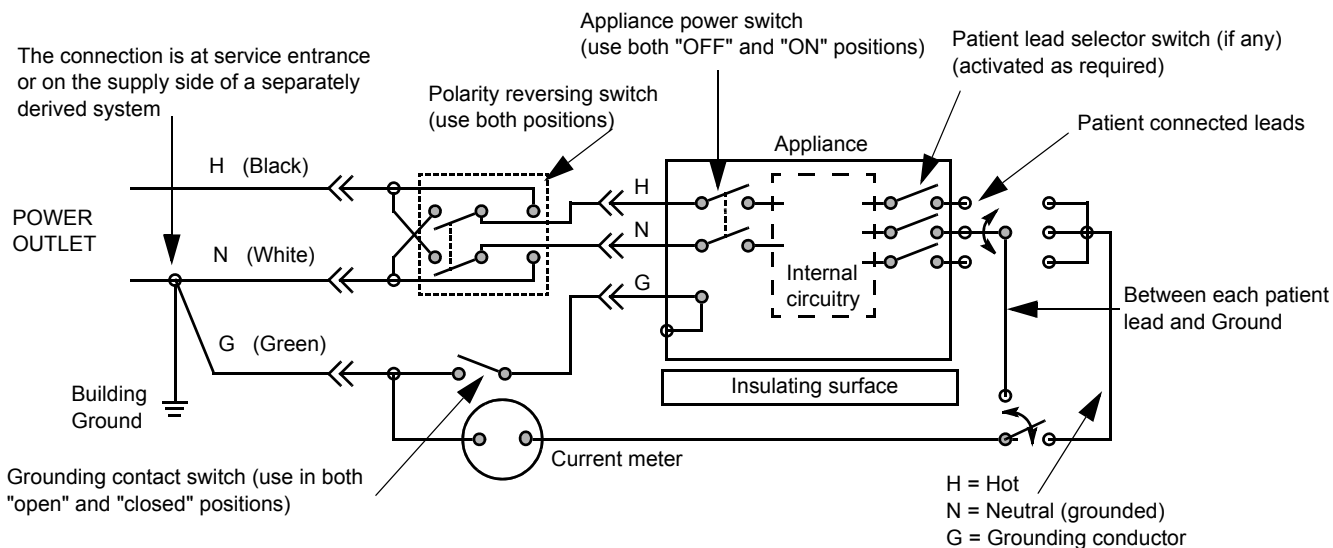

Figure 10-4 Test Circuit for Measuring Non-Isolated Patient Leads

10-7-7 Isolated Patient Lead (Source) Leakage – Lead-to-Lead

NOTE: Refer to the procedure in the IEC 60601-1.

10-7-8 Isolated Patient Lead (Sink) Leakage - Isolation Test

NOTE: Refer to the procedure in the IEC 60601-1.



CAUTION: Line voltage is applied to the ECG leads during this test. To avoid the risk of possible electric shock, the system being tested must not be touched by anyone (patient or operator), while the ISO TEST switch is depressed.

NOTE: It is not necessary to test each lead individually, or power condition combinations, as required in previous tests.

10-7-8-1 Data Sheet for ECG Current Leakage

The test passes when all readings measure less than the values shown in the tables below. Record all data on the [Vivid™ 3 Preventative Maintenance Inspection Certificate](#) (see page 10-30).

Table 10-16 Maximum Allowance Limit for ECG Lead Leakage Test to Ground

	AC Power Source	Maximum Allowance Limit	
		GROUND OPEN	GROUND CLOSED
Patient Lead-to-Ground Current Leakage Test and Patient Lead-to-Lead Current Leakage Test	115V	10uA	10uA
	220/240V	500uA	10uA

Table 10-17 Maximum Allowance Limit for ECG Lead Isolation Sink Test

	AC Power Source	Maximum Allowance Limit
Patient Lead Isolation Current Test	115V	20uA
	220/240V	5mA

Table 10-18 Typical Data Sheet for ECG Lead-to-Lead Test

ECG Power	Tester Polarity Switch	Tester Ground Switch	Tester Lead Selector				
			RL (N)	RA (R)	LA (L)	LL	C
ON	NORM	CLOSED					
ON	REVERSE	CLOSED					
ON	NORM	OPEN					
ON	REVERSE	OPEN					
OFF	NORM	CLOSED					
OFF	REVERSE	CLOSED					
OFF	NORM	OPEN					
OFF	REVERSE	OPEN					

10-7-9 Probe Current Leakage Test

10-7-9-1 Definition

This test measures the current that would flow to Ground (from any of the probes) through a patient who is being scanned, and who becomes grounded by touching some other grounded surface.

10-7-9-2 Generic Procedure

Measurements should be made with the Ground OPEN and CLOSED, with power line polarity *Normal* and *Reversed*, and with the unit OFF and ON. For each combination, the probe must be active to find the worst case condition.

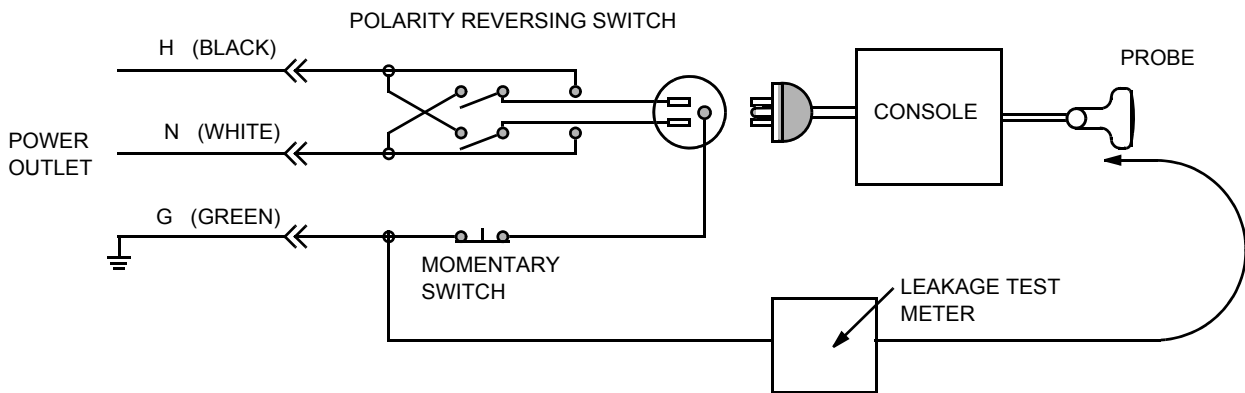

Figure 10-5 Set Up for Probe Current Leakage Test

NOTE: Each probe will have a certain amount of leakage current, depending on its design. Small variations in probe current leakages are normal from probe to probe. Other variations will result from differences in line voltage and test lead placement.

10-7-9-3 No Meter Probe Adapter Procedure

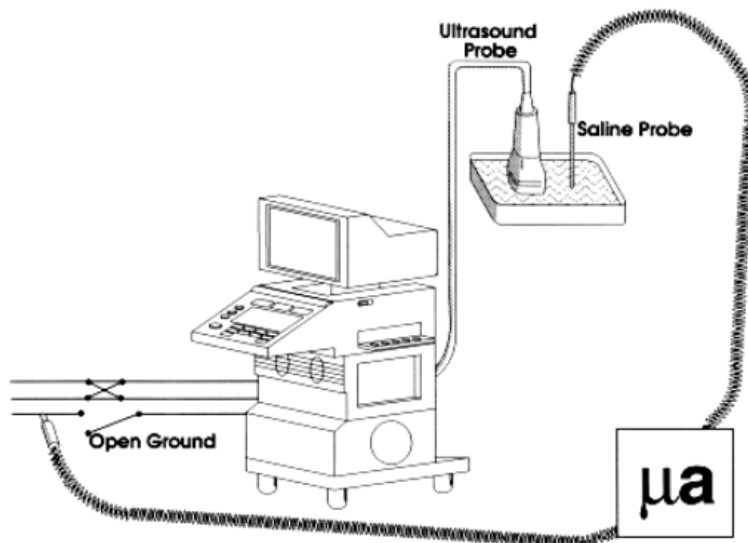

Figure 10-6 Check Without Probe Adapter

Follow these steps to test each transducer for leakage current.

- 1.) Turn the Vivid 3 unit OFF.
- 2.) Plug the unit into the test meter, and the meter into the tested AC wall outlet.
- 3.) Plug the external probe into the meter "EXTERNAL" connector.
- 4.) Set the meter's "FUNCTION" switch to EXTERNAL position.
- 5.) Connect the probe for test with the connector of the console.
- 6.) Add the saline probe and the imaging area of the probe into the saline bath.
- 7.) Turn unit power ON for the first part; turn it OFF for the second half.
- 8.) Depress the ISO TEST rocker switch and record the highest current reading.
- 9.) Follow the test conditions described in [Table 10-19](#) for every transducer.
- 10.) Keep a record of the results with other hard copies of PM data.

10-7-9-4 Data Sheet for Transducer Source Current Leakage

The test passes when all readings measure less than the values shown in [Table 10-13](#) and [Table 10-14](#). Record all data on the [Vivid™ 3 Preventative Maintenance Inspection Certificate](#) (see page 10-30).



CAUTION: When power to the unit is ON, *never* switch the Polarity and the status of Neutral . Be sure to turn OFF power to the unit before switching them, using the POLARITY switch and/or the NEUTRAL switch. *Failure to comply with this warning may cause damage to the unit!*

Table 10-19 Typical Data Sheet for Transducer Source Current Leakage Test

Transducer Tested:			
Unit Power	Tester Power POLARITY Switch	Tester GROUND or NEUTRAL Switch	Measurement
ON	NORM	OPEN	
ON	NORM	CLOSED	
ON	REV	OPEN	
ON	REV	CLOSED	
OFF	NORM	OPEN	
OFF	NORM	CLOSED	
OFF	REV	OPEN	
OFF	REV	CLOSED	

Section 10-8 Excessive Current Leakage

10-8-1 Possible Causes of Excessive Current Leakage

10-8-1-1 Chassis Fails

Check the Ground on the power cord and plug for continuity. Ensure the Ground is not broken, frayed, or intermittent. Replace any defective part.

Tighten all Grounds. Ensure star washers are under all Ground studs.

Inspect wiring for bad crimps, poor connections, or damage.

Test the wall outlet; verify it is grounded and is free of other wiring abnormalities. Notify the user or owner to correct any deviations. As a work around, check the other outlets to see if they could be used instead.

NOTE: No outlet tester can detect the condition where the white neutral wire and the green grounding wire are reversed. If later tests indicate high current leakages, this should be suspected as a possible cause and the outlet wiring should be visually inspected.

10-8-1-2 Probe Fails

Test the probe in another connector to verify if the fault lies with the probe or the scanner.

NOTE: Each probe will have some amount of leakage, dependent on its design. Small variations in probe current leakages are normal from probe to probe. Other variations will result from differences in line voltage and test lead placement. The maximum allowable leakage current for body surface contact probe differs from inter-cavity probe. Be sure to enter the correct probe type in the appropriate space on the check list.

If excessive leakage current is slot dependent, inspect the system connector for bent pins, poor connections, and Ground continuity.

If the problem remains with the probe, replace the probe.

10-8-1-3 Peripheral Fails

Tighten all Grounds. Ensure star washers are under all Ground studs.

Inspect wiring for bad crimps, poor connections, or damage.

10-8-1-4 Still Fails

If all else fails, begin isolation by removing the probes, external peripherals, then the on-board peripherals (one at a time) while monitoring the leakage current measurement.

10-8-1-5 New Unit

If the leakage current measurement tests fail on a new unit and if the situation cannot be corrected, submit a Safety Failure Report to document the system problem. Remove the unit from operation.

10-8-1-6 ECG Fails

Inspect cables for damage or poor connections.

Section 10-9 PM and Safety Inspection Certificates



Vivid™ 3 Preventative Maintenance Inspection Certificate

Customer Name:		System ID:	Dispatch Number / Date Performed:	Warranty/Contract/HBS
System Type		Model Number:	Serial Number:	Manufacture Date:
Probe 1:	Frequency:	Scan Format*:	Model Number:	Serial Number:
Probe 2:	Frequency:	Scan Format*:	Model Number:	Serial Number:
Probe 3:	Frequency:	Scan Format*:	Model Number:	Serial Number:
Probe 4:	Frequency:	Scan Format*:	Model Number:	Serial Number:
Probe 5:	Frequency:	Scan Format*:	Model Number:	Serial Number:
Probe 6:	Frequency:	Scan Format*:	Model Number:	Serial Number:
Probe 7:	Frequency:	Scan Format*:	Model Number:	Serial Number:
Probe 8:	Frequency:	Scan Format*:	Model Number:	Serial Number:
Probe 9:	Frequency:	Scan Format*:	Model Number:	Serial Number:

*Scan Format: Phased Array, Linear Array, Curved Array, Mechanical Array, or other

Functional Checks (if applicable)	OK? or N/A	Physical Inspection and Cleaning (if applicable)	Inspect	Clean
2D-Mode Function		Control Console		
Doppler Modes Function		Monitor		
CF-Mode Function		Air Filter		
M-Mode Function		Probe Holders		
Applicable Software Options		External I/O		
Applicable Hardware Options		Wheels, Brakes & Swivel Locks		
Control Console		Cables and Connectors		
Monitor		GE-approved Peripherals (VCR, CD-RW, MOD, Printers)		
Measurement Accuracy				
GE-approved Peripherals				

Comments:



Vivid™ 3 Electrical Safety Inspection Certificate

Electrical Test Performed	Max Value Allowed	Value Measured	OK?	Comments
Outlet (correct Ground & wiring config.)				
System Ground Continuity				
Chassis Source Current Leakage - Probe				
Chassis Source Current Leakage - Caster				
Chassis Source Current Leakage - CRT				
Patient Lead Source Leakage (Lead-to-Ground)				
Patient Lead Source Leakage (Lead-to-Lead)				
Patient Lead Source Leakage (Isolation)				
Peripheral 1 Current Leakage				
Peripheral 1 Ground Continuity				
Peripheral 2 Current Leakage				
Peripheral 2 Ground Continuity				
Peripheral 3 Current Leakage				
Peripheral 3 Ground Continuity				

PROBES

Probe Number (from page 10-30)	Max Value Allowed	Max Value Measured	OK?	Comments
Probe 1:				
Probe 2:				
Probe 3:				
Probe 4:				
Probe 5:				
Probe 6:				
Probe 7:				
Probe 8:				
Probe 9:				

Final Check: All system covers are in place. The Vivid™ 3 system scans with all probes, as expected.

Accepted by:



GE MEDICAL SYSTEMS

GE Medical Systems-Americas: Fax 414.544.3384
P.O. Box 414; Milwaukee, Wisconsin 53201-0414, U.S.A.

GE Medical Systems-Europe: Fax 33.1.40.93.33.33
Paris, France

GE Medical Systems-Asia: Fax 65.291.7006
Singapore

GE Vingmed Ultrasound: Fax: +47 3302 1350
Horten, Norway